

Modicon X80

BMXNOR0200H RTU Module

User Manual

(Original Document)

12/2018

E100000000505.09

www.schneider-electric.com



The information provided in this documentation contains general descriptions and/or technical characteristics of the performance of the products contained herein. This documentation is not intended as a substitute for and is not to be used for determining suitability or reliability of these products for specific user applications. It is the duty of any such user or integrator to perform the appropriate and complete risk analysis, evaluation and testing of the products with respect to the relevant specific application or use thereof. Neither Schneider Electric nor any of its affiliates or subsidiaries shall be responsible or liable for misuse of the information contained herein. If you have any suggestions for improvements or amendments or have found errors in this publication, please notify us.

You agree not to reproduce, other than for your own personal, noncommercial use, all or part of this document on any medium whatsoever without permission of Schneider Electric, given in writing. You also agree not to establish any hypertext links to this document or its content. Schneider Electric does not grant any right or license for the personal and noncommercial use of the document or its content, except for a non-exclusive license to consult it on an "as is" basis, at your own risk. All other rights are reserved.

All pertinent state, regional, and local safety regulations must be observed when installing and using this product. For reasons of safety and to help ensure compliance with documented system data, only the manufacturer should perform repairs to components.

When devices are used for applications with technical safety requirements, the relevant instructions must be followed.

Failure to use Schneider Electric software or approved software with our hardware products may result in injury, harm, or improper operating results.

Failure to observe this information can result in injury or equipment damage.

© 2018 Schneider Electric. All rights reserved.

Table of Contents



	Safety Information	9
	About the Book	13
Part I	The RTU Module for X80 Platforms	17
Chapter 1	About the BMX NOR 0200 H Module	19
	Introducing the BMXNOR0200H Module	19
Part II	BMXNOR0200H Hardware Characteristics	23
Chapter 2	Hardware Presentation	25
	Physical Description	26
	Module Dimensions	28
	LED Indicators	29
	Ethernet Port	31
	Serial Port	34
	Electrical Characteristics	36
	Standards and Certifications	37
Chapter 3	Hardware Installation	39
	Installing a Module	40
	Grounding of Installed Modules	42
	SD Memory Card	44
	Wiring Considerations	46
Part III	Communications Characteristics	47
Chapter 4	Ethernet Communications	49
4.1	Ethernet Services	50
	Ethernet Services Overview	50
4.2	IP Parameters	52
	Methods for IP Addressing	53
	Rotary Switches	54
	Deriving IP Parameters from the MAC Address	56
4.3	Modbus TCP/IP Messaging	57
	Data Exchange	58
	The Messaging Configuration Tab	59
	Messaging Configuration Parameters	60

4.4	SNMP	61
	SNMP and Schneider Private MIB Overview	62
	SNMP Communication	63
	SNMP Operations Example	65
4.5	SOAP Web Services	66
	Designing a SOAP Client Interface	66
Chapter 5	Serial Communications	69
	Serial Port	70
	Serial Communication Architectures	71
Chapter 6	Modem Communications	73
	Modem Communication	74
	Modem Support	75
	Modem Register Command	77
	Modem Communication Error Codes	79
	Connecting External Modem (RS232)	80
	How to work with External Modem	82
Part IV	Functional Description	87
Chapter 7	How to Work with RTU Protocols	89
7.1	RTU Protocols	90
	Communication Protocols	91
	IEC 60870-5-101/104 Protocols Overview	92
	DNP3 Protocols Overview	94
7.2	Clock Synchronization	96
	Clock Synchronization with the RTU Protocol Facilities	97
	Clock Synchronization with the NTP Protocol	98
7.3	Time Stamping	101
	Event Time Stamping	101
7.4	Events Management	102
	Overview	103
	Events Routing	106
	Events Backup	111
7.5	Integrity Poll Command	114
	Integrity Poll Command	114
7.6	Transmission Modes	117
	Overview	117
7.7	Connection Status	122
	Overview	122

7.8	Communication Error Codes	123
	RTU Protocols Communication Error Codes	123
Chapter 8	How to Work with Datalogging Service.	125
	About Datalogging Service	126
	Create a Datalogging Service	128
	Datalogging Properties	129
	Datalogging Configuration	131
	Datalogging File Format	135
	Recommendation on Datalogging Service	136
Chapter 9	How to Work with Email/SMS Service	137
	About the Email Service / SMS Service	138
	Create an Email Service	140
	Email Properties	141
	Email Configuration	143
Chapter 10	How to Work with Embedded Web Pages	147
10.1	Embedded Web Pages	148
	Introduction to Embedded Web Pages	148
10.2	Home Web Page	149
	Home Page	149
10.3	Setup Web Pages	150
	Module Setup	151
	Security	153
	FTP Security Page	155
10.4	Diagnostics Web Pages	156
	Diagnostics	157
	PLC Rack Viewer Page	158
	Messaging	160
	NTP Diagnostics	161
	Clock Diagnostics	163
	Statistics	164
	Upload MIB File	166
	Properties	167
10.5	Monitoring Web Pages	168
	Monitoring	169
	Data Editor	170
Part V	Configuring the Module.	171
Chapter 11	Configuring the Module.	173
	Configuration Methodology	173

Chapter 12	Configuration and Debug with Control Expert	175
12.1	Configuration with Control Expert	176
	Configuring with Control Expert	177
	Configuration Screen	180
12.2	Debugging with Control Expert	182
	Module Debugging Screen	183
	General Debugging Parameters	185
	Debugging Parameters for TCP/IP Utilities	187
Chapter 13	Configuration with the Setup Web Pages	189
13.1	Web Site Configuration Common	190
	Parameter Input Interface in Setup Web Pages	191
	Channel Configuration	195
	Serial Port Configuration	200
	Ethernet Port Configuration	208
	RTU Protocol Parameters	209
	Time Zone Configuration	210
	Module and Protocols Configuration File	212
	RTU Protocol Service Reset	216
	Backward Compatibility	217
13.2	Web Site Configuration IEC	219
	IEC 60870-5-101 Master RTU Protocol Parameters	220
	IEC 60870-5-101 Slave RTU Protocol Parameters	227
	IEC 60870-5-104 Client RTU Protocol Parameters	238
	IEC 60870-5-104 Server RTU Protocol Parameters	243
	IEC Data Object Mapping Page and Table	251
	IEC Data Object Mapping	262
	IEC Event Queue Setting	264
	IEC 60870-5-101/104 Master/Client	266
	IEC Data Length & Mapping Orientation	269
	IEC Data Object Type Mapped to Control Expert EDT/DDT	270
13.3	Web Site Configuration DNP3	273
	DNP3 Master/DNP3 NET Client RTU Protocol Parameters	274
	DNP3 Slave/Server RTU Protocol Parameters	280
	DNP3 Channel Configuration Over UDP	288
	DNP3 Data Object Mapping Page and Table	292
	DNP3 Data Object Mapping	308

	DNP3 Event Queue Setting	313
	DNP3 Master/ DNP3 Net Client	315
	DNP3 Data Length & Mapping Orientation	317
	DNP3 Data Object Type Mapped to Control Expert EDT/DDT	318
Chapter 14	Web Designer Configuration	321
	Create a Project	322
	PLC Device Configuration	325
	Data Editor Configuration	326
	Transfer	327
Appendices		329
Appendix A	Interoperability	331
	IEC 60870-5-101 Interoperability for BMXNOR0200H as Master	332
	IEC 60870-5-101 Interoperability for BMXNOR0200H as Slave	342
	IEC 60870-5-104 Interoperability for BMXNOR0200H as Client	352
	IEC 60870-5-104 Interoperability for BMXNOR0200H as Server	361
	DNP3 Interoperability for BMXNOR0200H as Master	370
	DNP3 Interoperability for BMXNOR0200H as Slave	381
Appendix B	Ethernet Language Objects	395
B.1	Language Objects and IODDTs of Ethernet Communication	396
	Language Objects and IODDTs of Ethernet Communication	397
	Implicit Exchange Language Objects Associated with the Application-Specific Function	398
	Explicit Exchange Language Objects Associated with the Application-Specific Function	399
B.2	Exchange Objects of Type T_COM_ETH_BMX	401
	Details of Implicit Exchange Objects of the IODDT Type T_COM_ETH_BMX	402
	Details of Explicit Exchange Objects of the IODDT Type T_COM_ETH_BMX	403
B.3	Language Objects Associated with BMXNOR0200H Module Configuration	405
	Language Objects for Implicit Exchange	406
	Language Objects for Explicit Exchange	407
	Glossary	409
	Index	413

Safety Information



Important Information

NOTICE

Read these instructions carefully, and look at the equipment to become familiar with the device before trying to install, operate, service, or maintain it. The following special messages may appear throughout this documentation or on the equipment to warn of potential hazards or to call attention to information that clarifies or simplifies a procedure.



The addition of this symbol to a “Danger” or “Warning” safety label indicates that an electrical hazard exists which will result in personal injury if the instructions are not followed.



This is the safety alert symbol. It is used to alert you to potential personal injury hazards. Obey all safety messages that follow this symbol to avoid possible injury or death.

DANGER

DANGER indicates a hazardous situation which, if not avoided, **will result in** death or serious injury.

WARNING

WARNING indicates a hazardous situation which, if not avoided, **could result in** death or serious injury.

CAUTION

CAUTION indicates a hazardous situation which, if not avoided, **could result** in minor or moderate injury.

NOTICE

NOTICE is used to address practices not related to physical injury.

PLEASE NOTE

Electrical equipment should be installed, operated, serviced, and maintained only by qualified personnel. No responsibility is assumed by Schneider Electric for any consequences arising out of the use of this material.

A qualified person is one who has skills and knowledge related to the construction and operation of electrical equipment and its installation, and has received safety training to recognize and avoid the hazards involved.

BEFORE YOU BEGIN

Do not use this product on machinery lacking effective point-of-operation guarding. Lack of effective point-of-operation guarding on a machine can result in serious injury to the operator of that machine.

 WARNING
UNGUARDED EQUIPMENT
<ul style="list-style-type: none">• Do not use this software and related automation equipment on equipment which does not have point-of-operation protection.• Do not reach into machinery during operation.
Failure to follow these instructions can result in death, serious injury, or equipment damage.

This automation equipment and related software is used to control a variety of industrial processes. The type or model of automation equipment suitable for each application will vary depending on factors such as the control function required, degree of protection required, production methods, unusual conditions, government regulations, etc. In some applications, more than one processor may be required, as when backup redundancy is needed.

Only you, the user, machine builder or system integrator can be aware of all the conditions and factors present during setup, operation, and maintenance of the machine and, therefore, can determine the automation equipment and the related safeties and interlocks which can be properly used. When selecting automation and control equipment and related software for a particular application, you should refer to the applicable local and national standards and regulations. The National Safety Council's Accident Prevention Manual (nationally recognized in the United States of America) also provides much useful information.

In some applications, such as packaging machinery, additional operator protection such as point-of-operation guarding must be provided. This is necessary if the operator's hands and other parts of the body are free to enter the pinch points or other hazardous areas and serious injury can occur. Software products alone cannot protect an operator from injury. For this reason the software cannot be substituted for or take the place of point-of-operation protection.

Ensure that appropriate safeties and mechanical/electrical interlocks related to point-of-operation protection have been installed and are operational before placing the equipment into service. All interlocks and safeties related to point-of-operation protection must be coordinated with the related automation equipment and software programming.

NOTE: Coordination of safeties and mechanical/electrical interlocks for point-of-operation protection is outside the scope of the Function Block Library, System User Guide, or other implementation referenced in this documentation.

START-UP AND TEST

Before using electrical control and automation equipment for regular operation after installation, the system should be given a start-up test by qualified personnel to verify correct operation of the equipment. It is important that arrangements for such a check be made and that enough time is allowed to perform complete and satisfactory testing.

WARNING

EQUIPMENT OPERATION HAZARD

- Verify that all installation and set up procedures have been completed.
- Before operational tests are performed, remove all blocks or other temporary holding means used for shipment from all component devices.
- Remove tools, meters, and debris from equipment.

Failure to follow these instructions can result in death, serious injury, or equipment damage.

Follow all start-up tests recommended in the equipment documentation. Store all equipment documentation for future references.

Software testing must be done in both simulated and real environments.

Verify that the completed system is free from all short circuits and temporary grounds that are not installed according to local regulations (according to the National Electrical Code in the U.S.A, for instance). If high-potential voltage testing is necessary, follow recommendations in equipment documentation to prevent accidental equipment damage.

Before energizing equipment:

- Remove tools, meters, and debris from equipment.
- Close the equipment enclosure door.
- Remove all temporary grounds from incoming power lines.
- Perform all start-up tests recommended by the manufacturer.

OPERATION AND ADJUSTMENTS

The following precautions are from the NEMA Standards Publication ICS 7.1-1995 (English version prevails):

- Regardless of the care exercised in the design and manufacture of equipment or in the selection and ratings of components, there are hazards that can be encountered if such equipment is improperly operated.
- It is sometimes possible to misadjust the equipment and thus produce unsatisfactory or unsafe operation. Always use the manufacturer's instructions as a guide for functional adjustments. Personnel who have access to these adjustments should be familiar with the equipment manufacturer's instructions and the machinery used with the electrical equipment.
- Only those operational adjustments actually required by the operator should be accessible to the operator. Access to other controls should be restricted to prevent unauthorized changes in operating characteristics.

About the Book



At a Glance

Document Scope

This guide explains the architectures and features supported by the in-rack BMXNOR0200H module for the Modicon Mx80 and M340 PAC modular controller platform. This guide includes instructions for setting up RTU functions and protocols that are used in various telemetry and supervisory control and data acquisition (SCADA) applications, such as: water and wastewater, oil and gas, power and hydropower, other distributed infrastructures.

Validity Note

This document is valid for EcoStruxure™ Control Expert 14.0 or later.

The technical characteristics of the devices described in the present document also appear online. To access the information online:

Step	Action
1	Go to the Schneider Electric home page www.schneider-electric.com .
2	In the Search box type the reference of a product or the name of a product range. <ul style="list-style-type: none">• Do not include blank spaces in the reference or product range.• To get information on grouping similar modules, use asterisks (*).
3	If you entered a reference, go to the Product Datasheets search results and click on the reference that interests you. If you entered the name of a product range, go to the Product Ranges search results and click on the product range that interests you.
4	If more than one reference appears in the Products search results, click on the reference that interests you.
5	Depending on the size of your screen, you may need to scroll down to see the data sheet.
6	To save or print a data sheet as a .pdf file, click Download XXX product datasheet .

The characteristics that are presented in the present document should be the same as those characteristics that appear online. In line with our policy of constant improvement, we may revise content over time to improve clarity and accuracy. If you see a difference between the document and online information, use the online information as your reference.

Related Documents

Title of documentation	Reference number
Modicon M580, M340, and X80 I/O Platforms, Standards and Certifications	EIO0000002726 (English), EIO0000002727 (French), EIO0000002728 (German), EIO0000002730 (Italian), EIO0000002729 (Spanish), EIO0000002731 (Chinese)
Modicon Controllers Platform Cyber Security, Reference Manual	EIO0000001999 (English), EIO0000002001 (French), EIO0000002000 (German), EIO0000002002 (Italian), EIO0000002003 (Spanish), EIO0000002004 (Chinese)
Modicon M580 Standalone, System Planning Guide for Frequently Used Architectures	HRB62666 (English), HRB65318 (French), HRB65319 (German), HRB65320 (Italian), HRB65321 (Spanish), HRB65322 (Chinese)
Modicon M580, Hardware, Reference Manual	EIO0000001578 (English), EIO0000001579 (French), EIO0000001580 (German), EIO0000001582 (Italian), EIO0000001581 (Spanish), EIO0000001583 (Chinese)
Modicon M340, Processors, Setup Manual	35012676 (English), 35012677 (French), 35013351 (German), 35013352 (Italian), 35013353 (Spanish), 35013354 (Chinese)
Modicon M340 for Ethernet, Communications Modules and Processors, User Manual	31007131 (English), 31007132 (French), 31007133 (German), 31007494 (Italian), 31007134 (Spanish), 31007493 (Chinese)
EcoStruxure™ Control Expert, I/O Management, Block Library	33002531 (English), 33002532 (French), 33002533 (German), 33003684 (Italian), 33002534 (Spanish), 33003685 (Chinese)

Title of documentation	Reference number
EcoStruxure™ Control Expert, Communication, Block Library	33002527 (English), 33002528 (French), 33002529 (German), 33003682 (Italian), 33002530 (Spanish), 33003683 (Chinese)
EcoStruxure™ Control Expert, System, Block Library	33002539 (English), 33002540 (French), 33002541 (German), 33003688 (Italian), 33002542 (Spanish), 33003689 (Chinese)
Web Designer for FactoryCast, User Manual	35016149 (English), 35016150 (French)

You can download these technical publications and other technical information from our website at www.schneider-electric.com/en/download.

Product Related Information

 WARNING
UNINTENDED EQUIPMENT OPERATION
<p>The application of this product requires expertise in the design and programming of control systems. Only persons with such expertise should be allowed to program, install, alter, and apply this product.</p>
<p>Follow all local and national safety codes and standards.</p>
<p>Failure to follow these instructions can result in death, serious injury, or equipment damage.</p>

Part I

The RTU Module for X80 Platforms

Chapter 1

About the BMX NOR 0200 H Module

Introducing the BMXNOR0200H Module

Overview

The BMXNOR0200H module brings Remote Terminal Unit (RTU) functionality to the Modicon Mx80 PAC platform.



The RTU system provides an extensive set of control and communications features including industry and telemetry standard protocols such as IEC 60870-5-101, IEC 60870-5-104, DNP3 and Modbus TCP.

About the Module

The BMXNOR0200H module is a ruggedized module, designed for installation and operation in harsh environments and extended operating temperature ranges.

For more detailed information, refer to *Modicon M580, M340, and X80 I/O Platforms, Standards and Certifications*.

The Modicon Mx80 PAC platform offers these features for telemetry applications:

- operations in extended temperature ranges and harsh environments
- in-rack RTU module with support for IEC 60870-5-101/104, DNP3, and Modbus TCP
- specialized function blocks (AGA, flow calculations)
- expandable rack-based modular I/O configurations and remote I/O capabilities
- high-density, discrete, analog, and I/O counting modules
- isolated input power supply (various voltage ranges available 24 Vdc, 24/48 Vdc, 125 Vdc, 100/240 Vac)
- built-in CPU and modules with serial and Ethernet communication ports

- support for Modbus TCP
- local or remote downloading of operating system firmware

The BMXNOR0200H module addresses a wide range of telemetry requirements:

- conformal coating and extended operating temperature ranges
- various communications methods
 - serial and TCP/IP networks
 - intranet
 - WAN
 - modem connections
- various modem connections
 - serial and radio modems
 - GSM and PSTN modems
 - IP modems (GPRS, ADSL)
- upstream communications with SCADA master stations for polling interrogation of data, backfilling of time stamped event data, receiving master commands
- downstream communications with other RTU substations, slave field devices and IEDs (for data collection), sending commands, and synchronizing distributed control
- remote programming and downloading of control program with Control Expert software through Ethernet or modem connections
- remote diagnostic and monitoring with a built-in Web server

RTU Architecture

This illustration shows the RTU architecture, from SCADA to RTU substations through various means of communication:

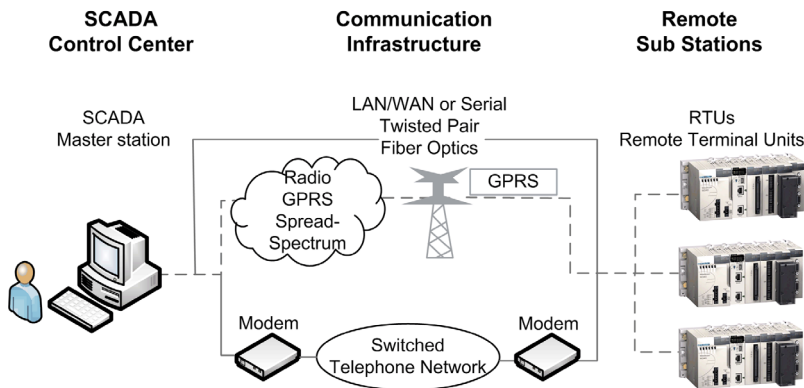

Functions and Protocols

The BMXNOR0200H module supports these functions and protocols:

- RTU protocols:
 - Built-in RTU protocols for serial or Ethernet communications
 - IEC 60870-5-101 (master or slave)
 - IEC 60870-5-104 (client or server)
 - DNP3 serial (master or slave)
 - DNP3 IP (client or server)
 - Modbus TCP (client or server)
- Main RTU Protocol Features
 - Time synchronization through protocol facility or NTP
 - Data synchronization on demand of the SCADA
 - Balanced and unbalanced transmission mode
 - Events management with time stamping - Sequence of Events (SOE)
 - Events queue stored in RAM memory (up to 100,000 events for all clients)
 - Events data backfill to SCADA application via protocol facility
 - Report by exception data exchanges
 - Unsolicited messaging data exchanges
 - Protocol setup via Web page
- Other built-in functions
 - Historical DataLogging with time stamping inside the module SD memory card
 - Email/SMS notifications
 - Web server for RTU set-up and remote diagnostic and monitoring
 - Advanced TCP/IP networking: NTP client, FTP client, or server, HTTP server, SOAP/XML, communication server, SNMP agent, SMTP client.

NOTE: When the BMXNOR0200H module works as IEC-104/DNP3 Client, the number of connected servers affects the module performance (webpage access, module start-up and data exchange through the backplane.)

Part II

BMXNOR0200H Hardware Characteristics

About This Part

This part contains an overview of hardware characteristics for the BMXNOR0200H module.

For Modicon M340 system installation and specifications, see the book *Modicon M340, Processors, Setup Manual*.

For Modicon M580 system installation and specifications, see the book *Modicon M580, Hardware, Reference Manual*.

What Is in This Part?

This part contains the following chapters:

Chapter	Chapter Name	Page
2	Hardware Presentation	25
3	Hardware Installation	39

Chapter 2

Hardware Presentation

What Is in This Chapter?

This chapter contains the following topics:

Topic	Page
Physical Description	26
Module Dimensions	28
LED Indicators	29
Ethernet Port	31
Serial Port	34
Electrical Characteristics	36
Standards and Certifications	37

Physical Description

External Features

The BMXNOR0200H module:

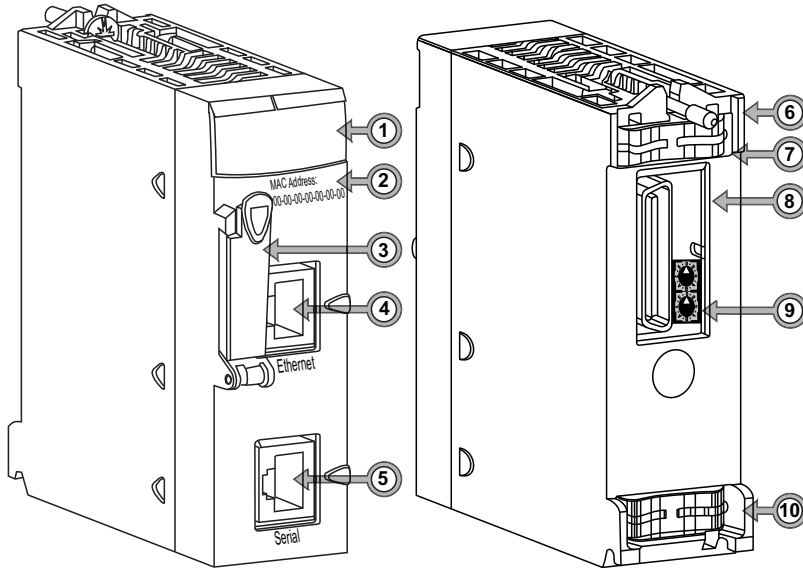

Callouts:

Item	Description	Description
1	LED display (<i>see page 29</i>)	diagnostic indications
2	MAC Address	unique address for each module, defined by the manufacturer
3	Memory card slot (<i>see page 44</i>)	SD card can store Web site files and datalogging CSV files
4	Ethernet port (RJ45 connector, 10BASE-T/100BASE-TX) (<i>see page 31</i>)	Functions include: <ul style="list-style-type: none"> ● Ethernet TCP/IP network connection ● Modbus TCP protocol support ● IEC 60870-5-104, DNP3 NET protocols support ● Control Expert remote programming
5	Serial port (RS 232C/RS 485, non-isolated) (<i>see page 70</i>)	Functions include: <ul style="list-style-type: none"> ● serial communications: IEC 60870-5-101 or DNP3 ● external modem management ● PPP/Modem communication: IEC 60870-5-104 or DNP3 NET protocol
6	Mounting screw	contact by screw tightening
7	Contact strip	contact by CEM clip 1

Item	Description	Description
8	Rack connector	plug to the X80 rack
9	Rotary switches (<i>see page 54</i>)	two rotary switches to provide a simple way to select an IP address
10	Contact strip	contact by CEM clip 2

NOTE: When the module is correctly installed on the rack, the contact strips connect the grounding bus of the module to the grounding bus of the rack.

Module Dimensions

Dimensions

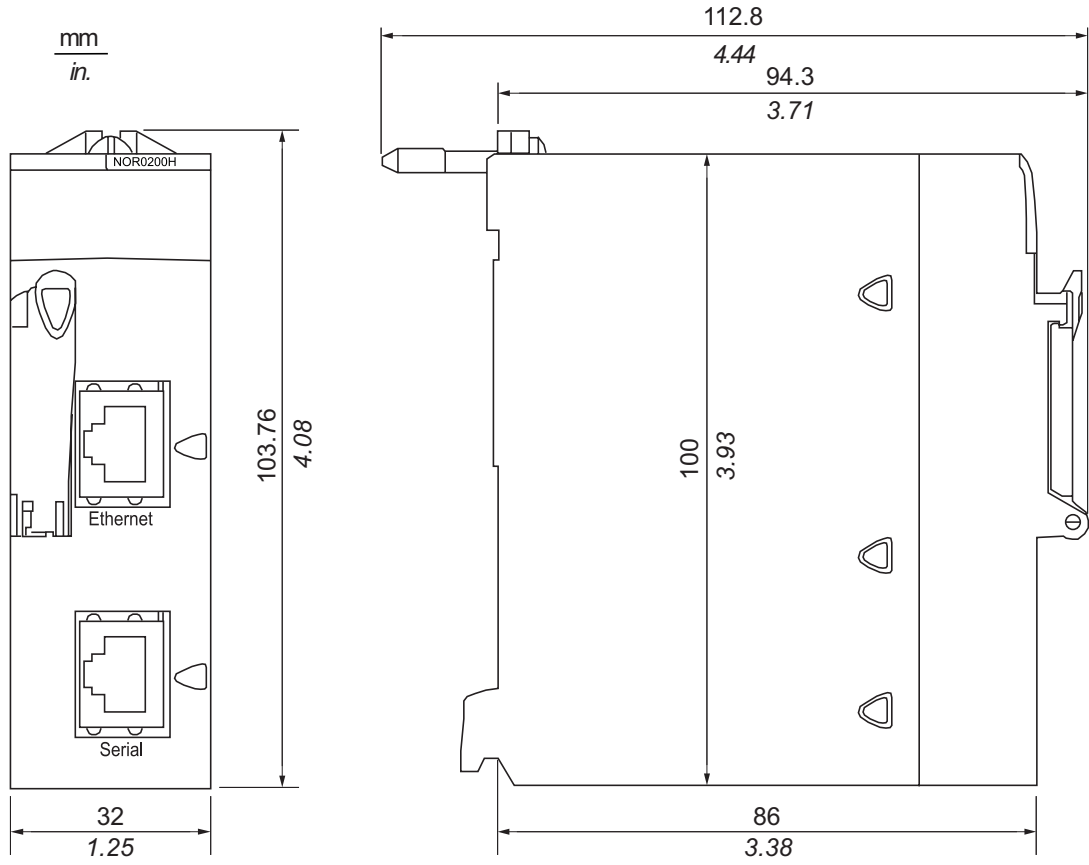

LED Indicators

Introduction

The LED indicators are located on the front of the module. LEDs provide information on:

- the memory card
- communication with the modules
- serial communication
- communication on the Ethernet network

LED Descriptions

This illustration shows the LED display on the BMXNOR0200H module:

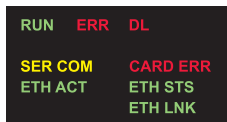

The colors and blink patterns of the LEDs indicate the status and operating conditions of Ethernet communications on the module:

Label	Pattern	Indication
RUN (green): operational state	on	The module is operating and configured.
	flashing	The module is blocked by a detected software error.
	off	The module is not configured. (The application is absent, invalid, or incompatible.)
ERR (red): detected error	on	The processor, system, or configuration detected an error.
	flashing	<ul style="list-style-type: none"> • The module is not configured. (The application is absent, invalid, or incompatible.) • The module is blocked by a detected software error.
	off	Operations are normal (no detected errors).
DL (red): download firmware (upgrade)	on	Firmware download is in progress.
	off	Firmware download is not in progress.
SER COM (yellow): serial data status	flashing	Data exchange (send/receive) on the serial connection is in progress.
	off	There is no data exchange on the serial connection.
CARDERR (red): memory card detected error	on	<ul style="list-style-type: none"> • The memory card is missing. • The memory card is not usable (bad format, unrecognized type).
	off	The memory card is valid and recognized.

Label	Pattern	Indication
ETH ACT (green): Ethernet communication (transmission/reception) activity	on	Communication activity is detected.
	off	No communication activity is detected.
ETH STS (green): Ethernet communication status	on	Communication is OK.
	2 flashes	A MAC address is not valid.
	3 flashes	The link is not connected.
	4 flashes	There is a duplicate IP address.
	5 flashes	The module is waiting for a server IP address.
	6 flashes	The module is in secure and safe mode (with default IP address).
	7 flashes	There is a configuration mismatch between the rotary switches and the internal configuration.
ETH LNK (green): Ethernet link status	on	An Ethernet link is detected.
	off	An Ethernet link is not detected.
<p>NOTE 1: Rapid flashing is defined as ON for 50 ms and OFF for 50 ms.</p> <p>NOTE 2: Slow flashing is defined as ON for 200 ms and OFF for 200 ms.</p>		

Ethernet Port

General

The BMXNOR0200H module has a built-in Ethernet port supporting either Ethernet communications via a modem communication or Modbus TCP/IP communication.

The following table describes the characteristics of the Ethernet communication channel:

Characteristic	Description
Protocols supported	RTU protocols: <ul style="list-style-type: none"> ● IEC 60870-5-104 (client or server) ● DNP3 NET (client or server) ● Modbus TCP/IP (client or server)
Connection	RJ45 female connector
Physical link	Ethernet 802.3 - Ethernet II

The Ethernet port on the module is a standard RJ45 connector. In an industrial environment, use a cable with the following characteristics:

- shielded twisted double pair
- impedance $100 \Omega \pm 15 \Omega$ (from 1 to 16 MHz)
- maximum attenuation 11.5 dB/100 meters
- maximum length 100 meters

The following straight-through ConneXium cables fit these requirements for connecting terminal devices:

Description	Reference		Length, m (ft)
	Low Smoke Zero Halogen	UL/CSA CMG	
Straight-through cable with RJ45 ends	490 NTW 000 02	490 NTW 000 02 U	2 (6.6)
	490 NTW 000 05	490 NTW 000 05 U	5 (16.4)
	490 NTW 000 12	490 NTW 000 12 U	12 (39.4)
	490 NTW 000 40	490 NTW 000 40 U	40 (131.2)
	490 NTW 000 80	490 NTW 000 80 U	80 (262.5)

Pin Assignment

The following illustration shows the Ethernet port:

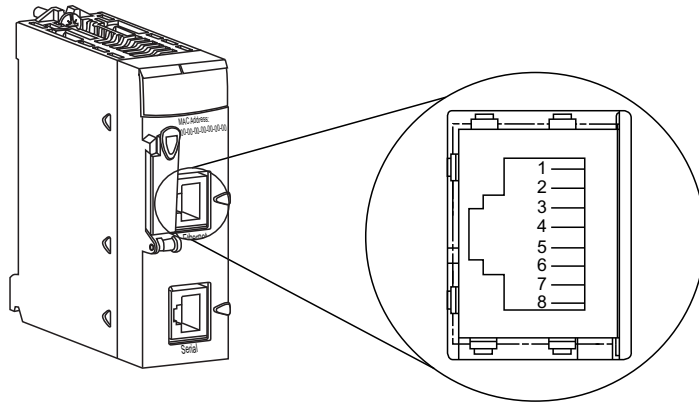

Pinout table:

Pin	Signal
1	TD+
2	TD-
3	RD+
4	not connected
5	not connected
6	RD-
7	not connected
8	not connected

NOTE: If there is a connection via a shielded cable, the connector casing on the module is linked up to the ground connection.

Line Speed

These line speeds are available for the BMXNOR0200H module:

- 100 Mbit/s in half duplex
- 100 Mbit/s in full duplex
- 10 Mbit/s in half duplex
- 10 Mbit/s in full duplex

The user can not configure the line speed. Characteristics of speed adaptation are:

- Auto-sensing and auto-negotiation allow the BMXNOR0200H module to quickly configure itself to the local Ethernet switch's speed and duplex mode.
- The negotiated speed between two Ethernet devices is limited to the speed of the slower device.

Serial Port

General

The BMXNOR0200H module has a built-in serial port supporting either serial communications via a serial link or modem communications via an external modem device (*see page 69*).

The following table describes the serial communication channels:

Characteristic	Description
Protocols supported	RTU protocols: <ul style="list-style-type: none"> ● IEC 60870-5-101 ● IEC 60870-5-104 (PPP/Modem) ● DNP3 serial ● DNP3 NET (PPP/Modem)
Connection	RJ45 female connector
Physical link	<ul style="list-style-type: none"> ● RS 485 non-insulated serial link ● RS 232 non-insulated serial link

Pin Assignment

The following illustration shows the RJ45 serial port:

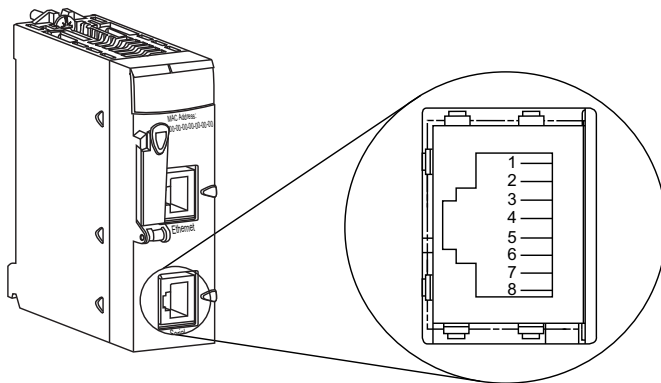

Pin	Signal	Pin	Signal
1	RXD	5	D0
2	TXD	6	CTS
3	RTS	7	Power supply
4	D1	8	Common
Shielding			

The RJ45 connector has eight pins. The pins used differ according to the physical link used.

The pins used by the RS 232 serial link are as follows:

- Pin 1: RXD signal
- Pin 2: TXD signal
- Pin 3: RTS signal
- Pin 6: CTS signal

The pins used by the RS 485 serial link are as follows:

- Pin 4: D1 signal
- Pin 5: D0 signal

Pins 7 and 8 are dedicated to the power supply of the man-machine interface via the serial link:

- Pin 7: 5 VDC/190 mA network power supply
- Pin 8: common of the network power supply (0 V)

NOTE: The RS 232 4-wire, RS 485 2-wire, and RS 485 2-wire and power supply cables use the same RJ45 male connector.

Electrical Characteristics

Consumed Current

This list shows the current that the BMXNOR0200H module consumes from the 24 VDC rack power and the residual dissipated power:

	BMXNOR0200H
Consumed current:	95 mA
Dissipated power	2.2 W

Standards and Certifications

Online Help

From the Control Expert online help, you can access the standards and certifications that apply to the modules in this product line by referring to the *Modicon M580, M340, and X80 I/O Platforms, Standards and Certifications* guide.

Download

Click the link that corresponds to your preferred language to download the standards and certifications (PDF format) that apply to the modules in this product line:

Language	
English	<i>Modicon M580, M340, and X80 I/O Platforms, Standards and Certifications</i>
French	<i>Modicon M580, M340, and X80 I/O Platforms, Standards and Certifications</i>
German	<i>Modicon M580, M340, and X80 I/O Platforms, Standards and Certifications</i>
Italian	<i>Modicon M580, M340, and X80 I/O Platforms, Standards and Certifications</i>
Spanish	<i>Modicon M580, M340, and X80 I/O Platforms, Standards and Certifications</i>
Chinese	<i>Modicon M580, M340, and X80 I/O Platforms, Standards and Certifications</i>

Chapter 3

Hardware Installation

What Is in This Chapter?

This chapter contains the following topics:

Topic	Page
Installing a Module	40
Grounding of Installed Modules	42
SD Memory Card	44
Wiring Considerations	46

Installing a Module

Precautions and Limitations

The BMXNOR0200H module may be installed in any of the positions in the rack except:

- the positions reserved for the rack power supply modules (marked PS, PS1, and PS2),
- the positions reserved for extended modules (marked XBE)
- the positions reserved for the CPU in the main local rack (marked 00 and 01 for M580 and marked 00 for M340),

The following diagram shows a rack assembly including a M340 CPU (in this case a BMX P34 2020) and a BMXNOR0200H module:

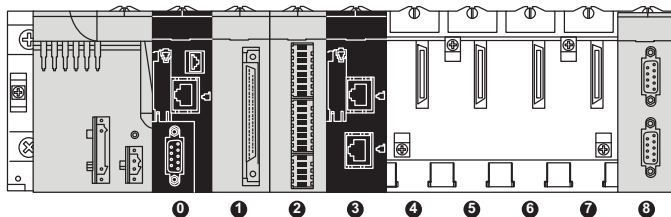

- 0 BMX P34 2020 at rack position 0
- 1 discrete I/O module at rack position 1
- 2 counter module at rack position 2
- 3 BMXNOR0200H module at rack position 3
- 4-7 available rack positions
- 8 extension module at rack position 8

NOTE: In a Modicon M340 system the total number of communication modules, such as BMX NOE 01•0 or BMXNOR0200H modules, cannot exceed two. The maximum Ethernet port for M340 system is 3 including the port on PLC. Therefore, a maximum of two BMXNOR0200H modules can be inserted in a M340 system.

NOTE: For Modicon M580 system module limitations, refer to chapter *System Throughput Considerations* (see *Modicon M580 Standalone, System Planning Guide for, Frequently Used Architectures*).

Mounting Instructions



WARNING

MODULE DESTRUCTION - LOSS OF APPLICATION

Disconnect all power to the rack before the installation of the BMXNOR0200H module.

Failure to follow these instructions can result in death, serious injury, or equipment damage.

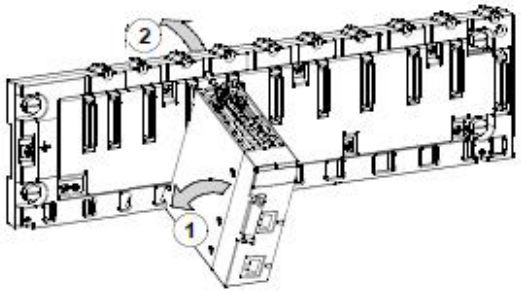
To mount a module on the rack:

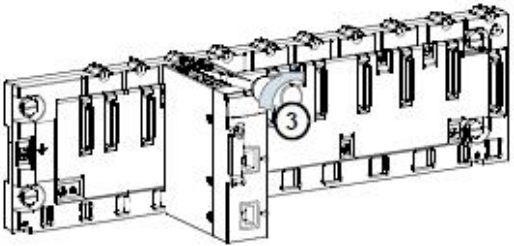
Step	Action	Illustration
1	<p>NOTE: Before installing a module, take off the protective cover from the module connector located on the rack.</p> <p>Position the two pins on the reverse side of the module (at the bottom) in the corresponding slots on the rack.</p>	
2	<p>Incline the module towards the top of the rack so that the module sits flush with the back of the rack. It is now set in position.</p>	
3	<p>Tighten the safety screw so that the module is held in place on the rack. The recommended tightening torque is between 0.4 and 1.5 Nm.</p>	

WARNING

UNINTENDED EQUIPMENT OPERATION

Check that the mounting screw is securely tightened to ensure the module is firmly attached to the rack.

Failure to follow these instructions can result in death, serious injury, or equipment damage.

Grounding of Installed Modules

General

The grounding of modules is crucial to avoid electric shock.

Grounding Processors and Power Supplies

DANGER

HAZARD OF ELECTRIC SHOCK, EXPLOSION OR ARC FLASH

Ensure ground connection contacts are present and not bent out of shape. If they are, do not use the module and contact your Schneider Electric representative.

Failure to follow these instructions will result in death or serious injury.

WARNING

UNINTENDED EQUIPMENT OPERATION

Tighten the clamping screws of the modules. A break in the circuit could lead to an unexpected behavior of the system.

Failure to follow these instructions can result in death, serious injury, or equipment damage.

All Modicon X80 modules are equipped with ground connection contacts at the rear for grounding purposes.

Example of Modicon X80 module:

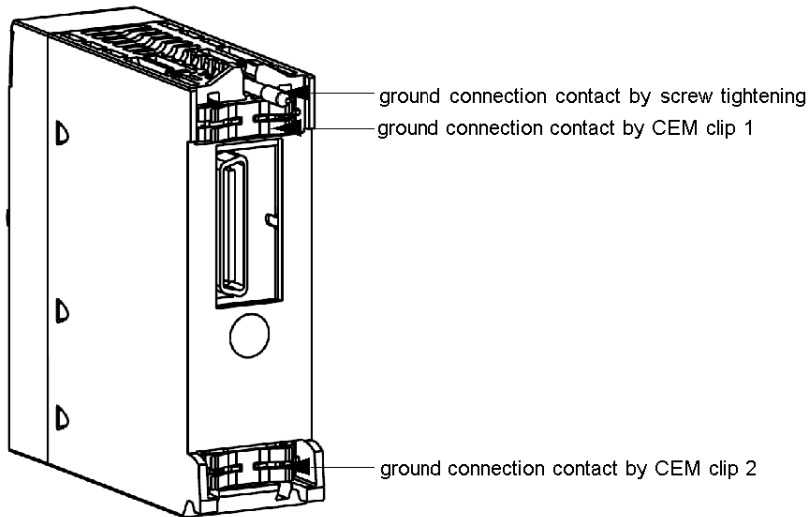

These contacts connect the grounding bus of the modules to the grounding bus of the rack.

SD Memory Card

Introduction

The Secure Digital (SD) memory card slot is located on the front of the BMXNOR0200H module (*see page 26*). The BMXRWS128MWF memory card is delivered with the module.

WARNING

RISK OF LOST APPLICATION

Do not remove the memory card from the module while the PLC is running. Remove the memory card only when the power is off.

Failure to follow these instructions can result in death, serious injury, or equipment damage.

Card Functionality

This table describes the functionality of the BMXRWS128MWF memory card when inserted into the BMXNOR0200H module:

SD Memory Card	Data Storage	Functionality
BMXRWS128MWF	128 MB	Memory for Web pages
		Storage of Datalogging files (CSV)

Card Services

NOTICE

INOPERABLE MEMORY CARD

Proceed with a firmware upgrade with Unity Loader tool when replacing the SD memory card.

Failure to follow these instructions can result in equipment damage.

NOTICE

INOPERABLE MEMORY CARD

Do not format the memory card with a non-Schneider tool. The memory card needs a structure to contain program and data. Formatting with another tool destroys this structure.

Do not use a write-protected memory card with the module. Some services do not operate properly when the memory card is write-protected.

Failure to follow these instructions can result in equipment damage.

Precautions

NOTICE

MEMORY CARD DESTRUCTION

- Do not touch the memory card connections.
- Keep the memory card away from electrostatic and electromagnetic sources as well as heat, sunlight, water and moisture.
- Avoid impacts to the memory card.
- Check the postal service security policy before sending a memory card by postal service. In some countries the postal service exposes mail to high levels of radiation, as a security measure. These high levels of radiation may erase the contents of the memory card and render it unusable.

Failure to follow these instructions can result in equipment damage.

Without SD Memory Card

If no memory card is inserted in the module, you cannot access the website. The following diagnostic message appears:

```
Access Error: Site temporarily unavailable. Try again. No SD card
present.
```

NOTE: The Modicon X80 RTU module works only with a memory card that is present at boot-up time. A memory card that is inserted during module operations is not recognized. Although operation is possible without a valid memory card inserted in the module, a valid memory card should be present at all times in the module.

Wiring Considerations

The Link

The following situations can create a temporary disruption in the application or communications:

- The RJ45 10/100 BASE-T interface connector gets connected or disconnected when the power is on.
- Modules are re-initialized when the power is switched back on.

Part III

Communications Characteristics

About this Part

This part describes Ethernet and Serial communications.

What Is in This Part?

This part contains the following chapters:

Chapter	Chapter Name	Page
4	Ethernet Communications	49
5	Serial Communications	69
6	Modem Communications	73

Chapter 4

Ethernet Communications

What Is in This Chapter?

This chapter contains the following sections:

Section	Topic	Page
4.1	Ethernet Services	50
4.2	IP Parameters	52
4.3	Modbus TCP/IP Messaging	57
4.4	SNMP	61
4.5	SOAP Web Services	66

Section 4.1

Ethernet Services

Ethernet Services Overview

Introduction

This topic introduces the different Ethernet services available via the BMXNOR0200H module:

- Support of Modbus TCP messaging (*see page 57*)
- Support of DNP3 NET and IEC 60870-104 protocols
- Built-in HTTP server
- Other supported IP protocols:
 - NTP client
 - FTP client / server
 - BootP client, DHCP / FDR client
 - SNMP agent (*see page 61*)
 - SMTP client
 - SOAP / XML server (*see page 66*)

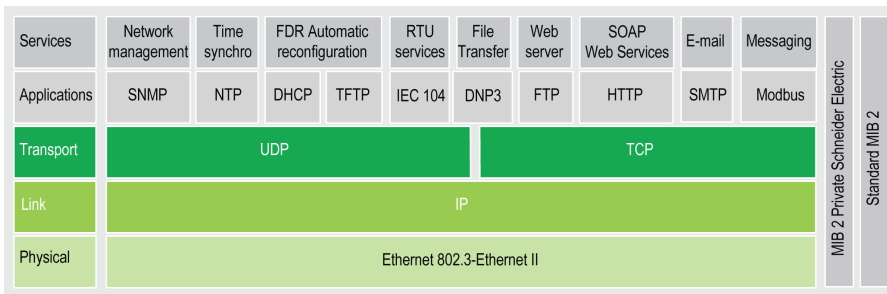

Modbus TCP Messaging

This service allows the exchange of data between devices supporting Modbus over TCP/IP.

NMT

The NMT (*Network Management*) protocol provides services for network initialization, diagnostic and control, and also device status control.

NTP

The NTP (*Network Time Protocol*) is a protocol used for synchronizing the clocks of computer systems. The time synchronization service establishes time accuracy among devices clocks over a Ethernet network.

FTP

The FTP (*File Transfer Protocol*) is the World Wide Web's file transfer protocol.

BootP

bootstrap protocol. A UDP/IP protocol that allows an Internet node to obtain its IP parameters based on its MAC address.

DHCP

The DHCP (*dynamic host configuration protocol*) is a TCP/IP protocol that allows network devices (DHCP clients) to obtain their IP addresses from a DHCP server through a request to the server.

FDR

The FDR (*fast device replacement*) service offers a method of handling device replacement without disrupting the system nor interrupting service.

SNMP

The SNMP (*simple network management protocol*) is a UDP/IP standard protocol used to monitor and manage nodes on an IP network. The SNMP agent supports both the MIB II and the Transparent Ready Private MIB (*see Modicon M340 for Ethernet, Communications Modules and Processors, User Manual*).

SMTP

The SMTP (*simple mail transfer protocol*) is a transmission protocol for sending e-mail. SMTP messages are usually retrieved from a server with an e-mail client (such as POP or IMAP).

SOAP / XML server

The SOAP (*Single Object Access Protocol*) carried via the HTTP (*Hyper Text Transfer Protocol*) channel.

Section 4.2

IP Parameters

About this Section

This section describes the assignment of IP parameters to the BMXNOR0200H module. Each network address must be valid and unique on the network.

What Is in This Section?

This section contains the following topics:

Topic	Page
Methods for IP Addressing	53
Rotary Switches	54
Deriving IP Parameters from the MAC Address	56

Methods for IP Addressing

Overview

Establish a standard procedure for assigning valid and unique IP addresses for each module and CPU on a network. The available methods are described below.

Addressing Methods

You can set the IP address for this advanced RTU module with its rotary switches (*see page 54*), the Control Expert IP Configuration tab (*see page 180*), or a combination of the two:

Address Method	Description
STORED	The lower rotary switch is set to STORED (manufacturer default setting), and the module uses the Control Expert application configured parameters.
device name (over DHCP)	<p>There are two components of the device name:</p> <ul style="list-style-type: none"> ● default device name of the module, for example BMX_0200_<i>xy</i> for a BMXNOR0200H module ● numeric value from 00 to 159 set on the rotary switches (<i>see page 54</i>) <p>(For the default device name, <i>xx</i> is the value of the upper rotary switch and <i>y</i> is the value of the lower rotary switch.)</p> <p>Example: For the RTU module, values of 120 (12 x 10) and 6 (6 x 1) on the respective upper and lower rotary switches indicate a value of 126. The value is appended to the default device name to create the valid DHCP device name (example: BMX_0200_126).</p>
CLEAR IP	The lower rotary switch is set to CLEAR IP , and the module uses its MAC-based default IP address (<i>see page 56</i>).
BOOTP	<p>Set the lower rotary switch (<i>see page 54</i>) to one of its BOOTP positions to get an address over BOOTP (see note).</p> <p>Note: To configure the module in the application to get its address from a BOOTP server, see "from a server," below.</p>
from a server (STORED)	<p>A server-assigned IP address can then be obtained from either a BOOTP or DHCP server.</p> <p>BOOTP:</p> <ul style="list-style-type: none"> ● Set the lower rotary switch to one of its STORED positions. ● Select From a server on the IP Configuration tab (<i>see page 180</i>). ● Leave the Device Name field empty. <p>DHCP:</p> <ul style="list-style-type: none"> ● Set the lower rotary switch to one of its STORED positions. ● Select From a server on the IP Configuration tab (<i>see page 180</i>). ● Enter a valid device name in the Device Name field. <p>Note: The X80 Ethernet modules will not receive an IP address from a BOOTP/DHCP server on application download if the IP configuration has not changed.</p>
disabled	Communications are disabled.
Note: A mismatch can occur when the assigned address is a mismatch for the address in the application.	

Rotary Switches

Introduction

The advanced RTU module operates as a single node on an Ethernet LAN and possibly other networks. The two rotary switches on the back of the module provide a simple way to assign a unique IP address:

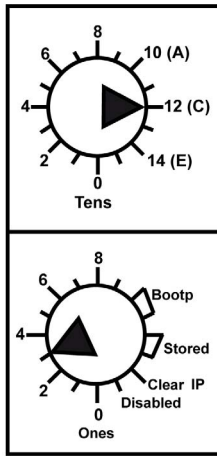

NOTE: Set the arrow firmly into the desired position. If you do not feel the switch click into place, the value of the switch may be incorrect or undetermined.

Summary of Valid IP Address Settings

Each rotary switch position that you can use to set a valid IP address is marked on the module. The following information summarizes the valid address settings:

- **device name:** For a switch-set device name, select a numeric value from 00 to 159. You can use both switches:
 - On the upper switch (Tens digit), the available settings are 0 to 15.
 - On the lower switch (Ones digit), the available settings are 0 to 9.

The device name is calculated from the sum of the two switch values. For example, the BMXNOR0200H advanced RTU module with the switch setting displayed in previous figure is assigned the DHCP device name **BMX_0200_123**.

The selection on the lower switch of any non-numeric position (**BOOTP**, **STORED**, **CLEAR IP**, **DISABLED**) makes the setting on the upper switch inconsequential.

- **BOOTP:** To get an IP address from a BOOTP server, select either of the two BOOTP positions on the bottom switch.
- **STORED:** The device uses the Control Expert application's configured (stored) parameters.
- **CLEAR IP:** The device uses the default IP parameters.
- **DISABLED:** The device does not respond to communications.

The functionality of the rotary switch when used in conjunction with the Control Expert IP Configuration tab (*see page 180*) is discussed throughout the IP Address chapter (*see page 52*).

Switch Labels

To assist you in setting the rotary switches to their proper positions, a label is affixed to the right side of the module. The switch settings are described in this table:

<p>The diagram shows a side view of a module with two rotary switches. The upper switch is labeled 'upper switch' and has positions 0 (Tens), 2, 4, 6, 8, 10 (A), 12 (C), and 14 (E). The lower switch is labeled 'lower switch' and has positions 0 (Ones), 2, 4, 6, 8, 10 (A), 12 (C), and 14 (E). The lower switch also has labels for 'Bootp' (A, B), 'Stored' (C, D), 'Clear IP' (E), and 'Disabled' (F).</p>	Upper Switch
	0 to 9: Tens value for the device name (0, 10, 20 ... 90)
	10(A) to 15(F): Tens value for the device name (100, 110, 120 ... 150)
	Lower Switch
	0 to 9: Ones value for the device name (0, 1, 2 ... 9)
	BOOTP: Set the switch to A or B to receive an IP address from a BOOTP server.
Stored: Set the switch to C or D to use the application's configured (stored) parameters.	
Clear IP: Set the switch to E to use the default IP parameters.	
Disabled: Set the switch to F to disable communications.	

Deriving IP Parameters from the MAC Address

Introduction

If no IP parameters are received from the application when the rotary switch (*see Modicon M340 for Ethernet, Communications Modules and Processors, User Manual*) is set to **Stored** or **Clear IP** positions, the module is configured at power-up with its default IP address. The default IP address for the module is derived from its hardware MAC address in accordance with a default IP address format.

Default IP Address Format

The default IP address format is `84.x.y.z`:

- `84`: a fixed value
- `x.y.z`: The last three fields in the default IP address correspond to the decimal equivalents of the last three bytes in the MAC address.

Example

For example a device with `00-00-53-12-01-C4` MAC address has the following default IP address: `84.18.1.196` (12 hex = 18 dec, 01 hex = 1 dec, C4 hex = 196 dec).

Section 4.3

Modbus TCP/IP Messaging

About this Section

This section describes the functions and characteristics of the Modbus TCP/IP profile.

What Is in This Section?

This section contains the following topics:

Topic	Page
Data Exchange	58
The Messaging Configuration Tab	59
Messaging Configuration Parameters	60

Data Exchange

Exchanges

Data exchanges take place in one of two modes:

- **server mode:** The RTU module supports all Modbus-over-TCP requests from the PLC.
- **client mode:** This type of exchange enables Modbus-over-TCP requests to be sent using the functions:
 - READ_VAR
 - WRITE_VAR
 - DATA_EXCH

For more details about functions, refer to *EcoStruxure™ Control Expert, Communication, Block Library*.

NOTE: The maximum Ethernet frame size depends on the type of transaction. The maximum frame size is 256 bytes for messaging.

The RTU module is used to manage these TCP connections using port 502 messaging:

- servers (32 connections)
- clients (16 connections)

Port 502

TCP/IP reserves specific server ports for specific applications through IANA (Internet Assigned Numbers Authority). Modbus requests are sent to registered software port 502.

Port 502 messaging paths:

- server path:
 - Port 502 messaging can process up to 8 incoming requests from the network. Requests are received during the previous scan and sent to the Modbus server in the IN section.
 - Port 502 messaging can process up to 8 responses from the Modbus server in the IN section (including writing the data into the socket).
- client path:
 - Port 502 messaging can process up to 16 outgoing requests from the application in the OUT section (including writing the data into the socket).
 - Port 502 messaging can process up to 16 incoming responses from the network in the IN section. Responses are sent to the application.

The Messaging Configuration Tab

Introduction

To limit access to the BMXNOR0200H module, set the access control parameters on the **Messaging** tab.

Messaging Tab

The following procedure shows how to access the **Messaging** page from the index page:

Step	Action
1	Access the module configuration screen.
2	Select the Messaging tab (see illustration below).

The **Messaging** tab is shown below:

NOR configuration screen:

The screenshot shows the configuration interface for the NOR module. At the top, there are tabs for Security, IP Configuration, Messaging (selected), SNMP, Address Server, and NTP. Below the tabs, there is a 'Connection configuration' section. Underneath, there is an 'Access Control' section with a checked checkbox. To the right of the checkbox is a table with 12 rows. The table has two columns: 'Access' and 'IP address'. Each row in the 'Access' column has a red checkmark, and the 'IP address' column is empty. At the bottom of the screen, there are two tabs: 'PLC bus' and 'Ethernet_NOR_1'.

Access	IP address
1	
2	
3	
4	
5	
6	
7	
8	
9	
10	
11	
12	

The messaging configuration parameters are discussed in detail on the following pages.

Messaging Configuration Parameters

Accessing Messaging Configuration Parameters

Configuration parameters can be accessed in two areas on the Messaging tab screen:

- the **Connection Configuration** area
- the **Access Control** area

Connection Configuration Area

The **Connection Configuration** area is used to:

- activate an access control utility
- list the remote devices that can connect to the module according to a communication protocol

Access Control

The **Access Control** box is used to activate or deactivate control of remote devices that are attempting to open a TCP connection to the module. The functionality depends on whether the box is checked or not:

- **checked:** Access control management is activated and the **Access** column of the table is active (no longer grayed out).
 - The module can only communicate to the addresses entered in the 128 available spaces in the **IP address** column.
 - With the module in client mode it can only connect to remote devices selected by the **Access** column in the **Connection Configuration** table.
- **unchecked:** Access control management is inoperative and the **Access** column of the table is not active (grayed out).
 - With the module in server mode, remote third-party devices can connect as clients (before communicating with the module) without being declared in the table.

NOTE: Access control is only effective on the TCP/IP profile and assists module operations in server and client mode.

NOTE: If you select the **Access Control** check box but do not enter addresses in the **IP address** column, messaging will stop working.

Section 4.4

SNMP

About this Section

This section describes the Simple Network Management Protocol (SNMP).

What Is in This Section?

This section contains the following topics:

Topic	Page
SNMP and Schneider Private MIB Overview	62
SNMP Communication	63
SNMP Operations Example	65

SNMP and Schneider Private MIB Overview

Introduction

An SNMP agent runs on:

- Ethernet communication modules
- CPUs with embedded Ethernet communications ports

Network management systems use SNMP to monitor and control Ethernet architecture components for the rapid network diagnosis.

Network management systems allows a network manager to:

- monitor and control network components
- isolate troubles and find their causes
- query devices, such as host computer(s), routers, switches, and bridges, to determine their status
- obtain statistics about the networks to which they are attached

NOTE: Network management systems are available from a variety of vendors. Schneider Electric provides an SNMP-based diagnostics tool called ConneXview.

Simple Network Management Protocol

Ethernet communication modules support SNMP, the standard protocol for managing local area networks (LANs). SNMP defines exactly how a manager communicates with an agent. SNMP defines the format of:

- requests that a manager sends to an agent
- replies that the agent returns to the manager

The MIB

The set of objects that SNMP can access is known as a Management Information Base (MIB). Ethernet monitoring and management tools use standard SNMP to access configuration and management objects included in the device's MIB, providing that:

- objects that SNMP can access are defined and given unique names
- manager and agent programs agree on the names and meanings of fetch and store operations

Transparent Ready products support two SNMP network management levels:

- **Standard MIB II:** This first level of network management can be accessed via this interface. It lets the manager identify the devices that create the architecture and retrieve general information on the configuration and operation of the Ethernet TCP/IP interface.
- **MIB Transparent Ready interface:** Schneider has obtained a private MIB, *groupeschneider (3833)* (see *Modicon M340 for Ethernet, Communications Modules and Processors, User Manual*). This MIB includes a set of data that enables the network management system to supervise the Ethernet services. The Transparent Ready private MIB can be downloaded from the Web server on any Transparent Ready module in a PLC.

SNMP Communication

Overview

SNMP defines network management solutions in terms of network protocols and the exchange of supervised data.

The SNMP structure relies on the following elements:

- **Manager:** The manager allows entire or partial network supervision.
- **Agents:** Each supervised device has one or more software modules named "Agent" that are used by the SNMP protocol.
- **MIB:** The Management Information Base is a database or collection of objects.

The SNMP agent is implemented on the BMXNOR0200H module. This allows a manager to access MIB-II standardized objects from the Modicon X80 agent through the SNMP protocol. The MIB-II allows management of TCP/IP communication layers.

On the modules that support Ethernet communications, it is possible to access objects from the MIB Transparent Factory, which provides specific information about Messaging.

The following figure shows the tree structure of the TFE Ethernet MIB:

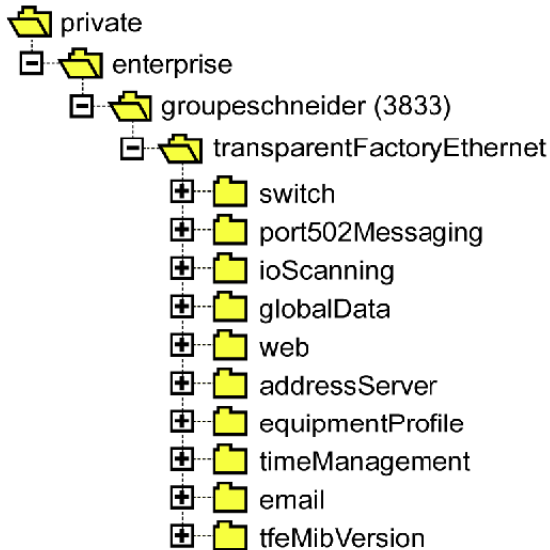

The source file of the TFE private MIB (*see Modicon M340 for Ethernet, Communications Modules and Processors, User Manual*) is available on modules and CPUs that support Ethernet communications. The MIB can be uploaded from the module webpage by selecting Upload MIB File (*see page 166*). This file may be compiled by the major SNMP managers on the market.

SNMP Protocol

The SNMP protocol defines 5 types of messages between the agent and the manager. These messages are encapsulated in UDP datagrams.

Messages from the manager to an agent:

- **Get_Request**: message used to obtain the value of one or more variables
- **Get_Next_Request**: obtains the value of the next variables
- **Set_Request** : sets the value of a variable

Messages from an agent to the manager:

- **Get_Response**: allows the agent to resend the value of the requested variable.
- **Trap**: allows asynchronous event signaling by the agent.

SNMP Operations Example

Modicon M340 Example

The SNMP manager transmits read or write requests (`Set_Request`, `Get_Request`, `Get_Next_Request`, etc.) for objects defined in the MIB - II SNMP and the SNMP agent of the Modicon M340 module responds.

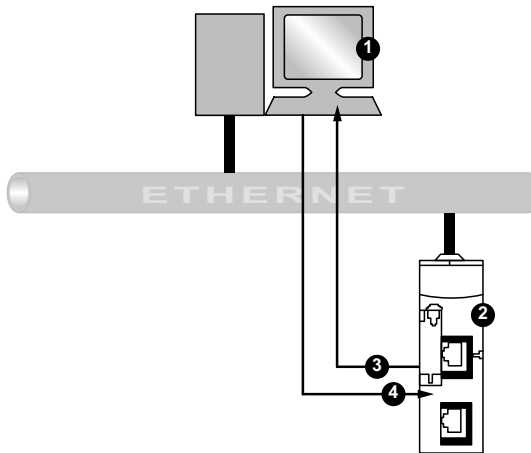

- 1 SNMP manager
- 2 SNMP agent (Modicon M340)
- 3 `Get_Response` trap
- 4 `Set_Request`, `Get_Request`, `Get_Next_Request`

The module's SNMP agent transmits events (traps) to the Manager. The managed trap systems are as follows:

- `Coldstart Trap`:
 - On the `BMXNOR0200H` modules, the event is transmitted following a module supply Reset, a processor Reset, or the downloading of an application to the PLC.
- `Authentication Failure Trap`: An event is transmitted indicating that a network element cannot be authenticated. The **Community Name** field in the received message is different to the one configured on the module. This trap can be enabled during module configuration.

Section 4.5

SOAP Web Services

Designing a SOAP Client Interface

Introduction

A server interface enables a SOAP (Simple Object Access Protocol) client application to communicate directly with a BMXNOR0200H Web server module.

SOAP / XML Communications

SOAP Web services are fully compliant with the W3C WS-I Web services standards. These services provide an open and standard communication means for control level devices to interact directly with information management applications using non proprietary SOAP protocol.

Web services are based on standards such as:

- SOAP, the exchange protocol carried out over the HTTP (HyperText Transfer Protocol) channel.
- WSDL (Web Services Description Language), in XML format.
- XML (eXtensible Markup Language), the universal data exchange standard.

BMXNOR0200H SOAP Web services act as SOAP server interfaces. They allow developers to easily design client applications that can exchange data directly with BMXNOR0200H Web servers. Applications such as Microsoft.NET, SQL Server, Microsoft Office (Excel), IBM (WebSphere), SUN (Java, Eclipse), Lotus, Oracle, SAP, MES, ERP and so forth can be interfaced directly with BMXNOR0200H using SOAP Web services.

Two kinds of Web services are provided in BMXNOR0200H modules as SOAP server interfaces:

- ModbusXMLDA: Web service to implement data access to Modbus variables,
- SymbolicXMLDA: Web service to implement Symbolic data access.

The Web services provided by BMXNOR0200H are compatible with the WS-I basic profile 1.1.

A SOAP Client Interface

The following table describes the process of designing a SOAP client interface:

Stage	Action
1	Create the client application: The development environment (for example, Visual Studio.net) connects to a WEB server module where it can access a list of available WEB services. The WEB server returns descriptions of the requested services as WSDL objects.
2	Develop the client application: The developer integrates the WEB service APIs using the code retrieved in the previous stage as a WEB reference and generates the client application.
3	Execute the client application: In run mode, the client application communicates in real time with the WEB server module using the SOAP protocol.

Chapter 5

Serial Communications

What Is in This Chapter?

This chapter contains the following topics:

Topic	Page
Serial Port	70
Serial Communication Architectures	71

Serial Port

Serial Communication

Serial mode is a point-to-point mode of data exchange between two entities. This provides communication between master stations, substation devices, RTUs, and Intelligent Electronic Devices (IEDs). It establishes client/server communication between different modules with a serial link. The master is the client and the slave modules are the servers. The BMXNOR0200H serial link module is a asynchronous serial line module that supports RTU Serial (master or slave connections).

Serial communication using the BMXNOR0200H module is only possible using the RTU serial protocols:

- IEC 60870-5-101 (master or slave)
- DNP3 serial (master or slave)

NOTE: The serial port is also used for the communication with an external modem (*see page 73*). If a modem is connected, it is possible to perform serial RTU communication or Ethernet RTU communication which depends on the type of modem.

Serial Communication Architectures

General

All equipment connected via serial link to a BMXNOR0200H module use either:

- an RS232 serial crossover cable
- an RS485 serial crossover cable

Connecting Equipment

The BMXNOR0200H module uses serial link:

- as master, in case of communication with several slaves with serial RTU protocols
- as slave, when the module is directly linked with master or a supervisor (SCADA for example)

Master case:

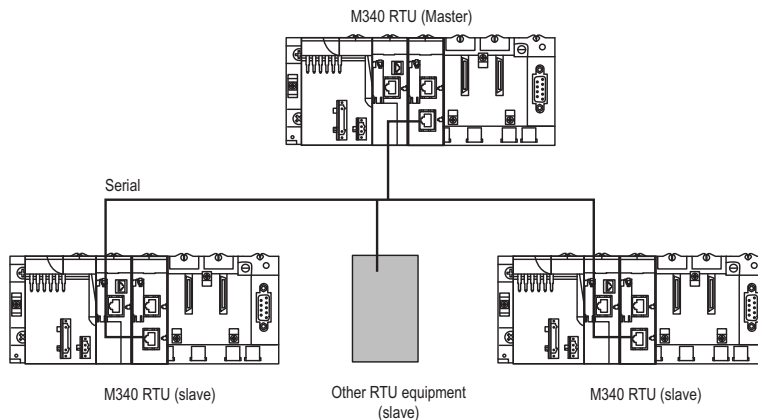

Slave case:

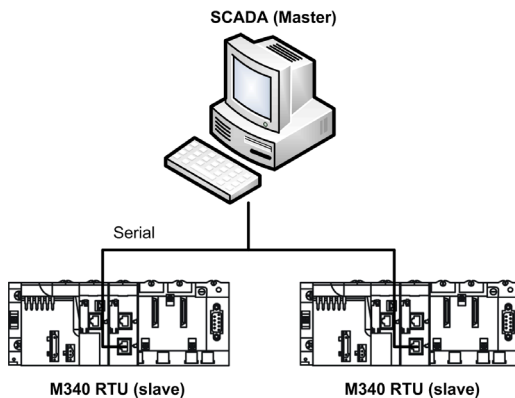

RS 232 Serial Crossover Cable

The TCS MCN 3M4F3C2 serial crossover cable has two connectors:

- RJ45 male
- Nine-pin SUB-D female

The illustration below shows the pin assignment for a TCS MCN 3M4F3C2 serial cross cable:

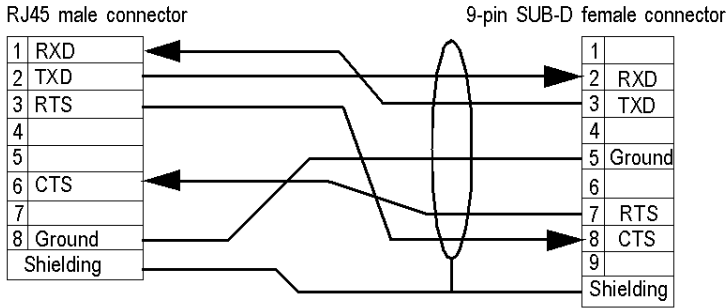

Connecting Cables and Accessories

The table below shows the product references of the cables and adapters to be used according to the serial connector used by the equipment:

Serial Connector for Data Terminal Equipment	Wiring
Nine-pin SUB-D male connector	TCS MCN 3M4F3C2 cable
25-pin SUB-D male connector	<ul style="list-style-type: none"> ● TCS MCN 3M4F3C2 cable ● TSX CTC 07 adapter
25-pin SUB-D female connector	<ul style="list-style-type: none"> ● TCS MCN 3M4F3C2 cable ● TSX CTC 10 adapter

Chapter 6

Modem Communications

What Is in This Chapter?

This chapter contains the following topics:

Topic	Page
Modem Communication	74
Modem Support	75
Modem Register Command	77
Modem Communication Error Codes	79
Connecting External Modem (RS232)	80
How to work with External Modem	82

Modem Communication

Overview

The BMXNOR0200H module can be used with several external modem types:

- Radio
- PSTN
- GSM
- GPRS
- ADSL

There are three different ways to connect an external modem to a BMXNOR0200H module:

- via the serial port, using serial communication protocol (IEC 60870-5-101 or DNP3 serial)
- via the serial port and configuring a Point-to-Point Protocol (PPP) connection, using ethernet communication protocol (IEC 60870-5-104 or DNP3 NET)
- via the ethernet port and configuring a Point-to-Point Protocol over Ethernet (PPPoE) connection, using ethernet communication protocol (IEC 60870-5-104 or DNP3 NET)

NOTE: PPPoE connection is only used with an ADSL external modem.

Modem Support

Connection via Serial Link

The serial link connection can be used to configure and communicate with an external modem (Radio/PSTN/GSM).

By default, the modem waits for an incoming call (Dial-in mode). When it receives an incoming call, try to establish the connection.

NOTE: In the Dial-out mode, the serial link connection via modem can be created in the Permanent mode (automatic connection at startup, at reboot or after connection loss) or in the On-demand mode (by an internal register command).

NOTE: In the On-demand mode, Dial out is prior to Dial in. and Dial out may interrupt established connection in Dial in mode.

Connection Point-to-Point Protocol via Serial Link

The BMXNOR0200H module supports PPP connections over serial links via a modem (PSTN/GSM/GPRS).

With a PPP connection, once a telephone connection has been established, the modem link is treated as a TCP/IP link.

A PPP connection enables two specific modes:

- Server mode, which is the Dial-in mode
- Client mode, which is the Dial-out mode.

NOTE: In the Client mode, the PPP connection via modem can be created in the Permanent mode (automatic connection at startup, at reboot or after connection loss) or in the On-demand mode (by an internal register command).

NOTE: For PPP connection authentication, the identification uses the Password Authentication Protocol (PAP). Use PAP to configure any device that has a modem/PPP connection with the BMXNOR0200H module. The Challenge Handshake Authentication Protocol (CHAP) is not implemented on the module. For an accepted connection, the PAP Username and Password of the remote device must be known. The BMXNOR0200H module password and user name used by the PAP protocol are the same as those of the HTTP server (by default: USER/USER).

The local IP address of the BMXNOR0200H module can be configured using the IP address either:

- specified by the User directly from the website. This is mandatory if the module is in Server mode.
- obtained from the PPP server (if specifying 0.0.0.0 as local IP) when establishing connection in Client mode. The IP can then be a static or a dynamic address.

NOTE: In Server mode and no IP address is given by the User, the Server assigns a fixed IP to the remote device with local IP+1. For example if the server IP is 90.0.0.2, remote device IP is then 90.0.0.3.

NOTE: GPRS does not support server mode.

Connection PPPoE via Ethernet Link

The Ethernet link connection can be used to configure and communicate with an external modem (type ADSL).

PPPoE connection is only available using Client mode (Server mode not supported).

NOTE: In the Client mode, the PPPoE connection via modem can be created in the Permanent mode (automatic connection at startup, at reboot or after connection loss) or in the On-demand mode (by an internal register command).

NOTE: For PPPoE connection authentication, the identification uses the Password Authentication Protocol (PAP). Use PAP to configure any device that has a modem/PPPoE connection with the BMXNOR0200H module. The Challenge Handshake Authentication Protocol (CHAP) is not implemented on the module. For an accepted connection, the PAP Username and Password of the remote device may be configured in PPPoE panel from the website.

The configuration of IP address is not available for users. The BMXNOR0200H module obtains a static or dynamic IP address when the PPPoE connection is established.

Modem Register Command

Introduction

Modem register commands are specified memory area allocated on the CPU. This memory area is used to send commands from CPU to the BMXNOR0200H module via the rack to control the connection or disconnection of the modem using logic functions.

Register Command

The commands are composed of 4 registers (%MW):

Register number	Parameter	Definition	Value
0	Command	Logic function to establish/close a connection. Disconnect command takes effect if it changes between 2 and 65535.	<ul style="list-style-type: none"> ● 1: connect ● 2...65535: disconnect
1	Index	Value in phone list in which are set telephone number, IP, password, and user name - not used for GPRS and PPPoE.	Range from 1...64
2	Command status	Execution status of Reg 0 command while establishing a connection.	<ul style="list-style-type: none"> ● 0000 hex: idle ● 0001 hex: on going ● 0002 hex: OK ● 8001 hex: detected error - Invalid phone index ● 8002 hex: detected error - unable to initialize ● 8003 hex: detected error - unable to dial-out ● 8004 hex: detected error - unable to make a PPP connection ● 8005 hex: detected error - unable to hang up ⁽¹⁾
3	Connection status	Status of the connection.	<ul style="list-style-type: none"> ● 0: closed ● 1: open
1: This feature is available with firmware V1.7 or later.			

NOTE: The command register are exchanged via the rack so the performance depends on CPU scan period, the workload of the RTU protocol and the number of BMXNOR0200H modules inserted in the rack.

For PPP/Modem and PPPoE Link, another 4 registers (%MW) following above registers are used to show local IP and remote IP address:

Register number	Parameter	Definition
4/5	Local IP	IP address is stored as MSB.
6/7	Remote IP	IP address is stored as MSB.

For example: %MW100 = 0A0B hex, %MW101= 0C0D hex, which means this IP is "10.11.12.13".

Example for modem register:

Register 3	Register 2	Reg 1	Reg 0	Comment	Case
Connection status	Command status	Index	Command		
0	0000 hex	0	0	original	-
0	0001 hex (on going)	1	1	connect (dial-out)	OK
1	0002 hex (command OK)	1	1		
0	0001 hex (on going)	1	1	connect (dial-out)	NOK
0	8001 hex/8002 hex/8003 hex/8004 hex	1	1		
1	0001 hex (on going)	1	2	disconnect (hang up)	OK
0	0002 hex (command OK)	1	2		
0	0000 hex (idle)	1	2		
1	0001 hex (on going)	1	2	disconnect (hang up)	NOK
0	8001 hex/8002 hex	1	2		
1	0001 hex (on going)	1	3	disconnect (repeat hang up)	OK
0	0002 hex (command OK)	1	3		
0	0000 hex (idle)	1	3		
1	0001 hex (on going)	1	3	disconnect (repeat hang)	NOK
0	8001 hex/8002 hex	1	3		

Modem Communication Error Codes

Introduction

In order to diagnose modem, error codes are available in Modem Diagnostic Web page.

Error Codes

The table below describes the modem communication error codes:

Value	Bit	Definition
00000100 hex	8	The phone index is not available in your phone list.
00000200 hex	9	PPP is not enabled when PSTN/GSM/GPRS modem is set.

Connecting External Modem (RS232)

General

For an external modem, the RTS and CTS pins are connected directly (not crossed).
External modems are connected to a BMXNOR0200H module by a serial direct cable using an RS232 physical link. BMXNOR0200H module works with many commercially available modems.

Application

The illustration below shows how a modem is connected to a slave BMXNOR0200H module configured with PPP:

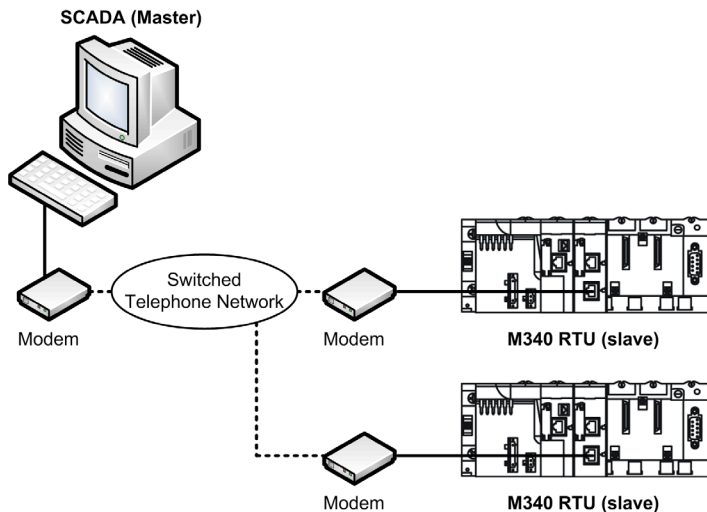

NOTE: In case of a PPPoE configuration, connect the modem on the Ethernet port of the BMXNOR0200H module.

RS 232 Serial Direct Cable

The TCS MCN 3M4M3S2 serial direct cable has two connectors:

- RJ45 male,
- Nine-pin SUB-D male.

The illustration below shows the pin assignment for a TCS MCN 3M4M3S2 serial direct cable:

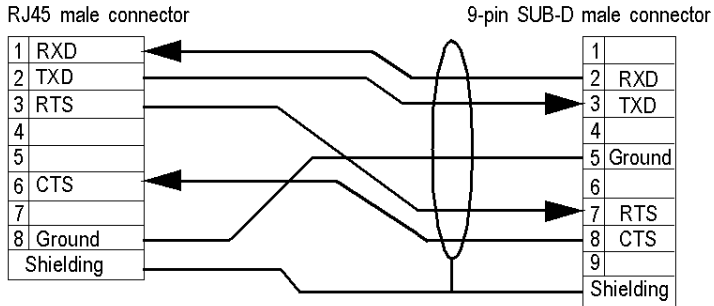

Connecting Cables and Accessories

The table below shows the product references of the cables and adapters to be used according to the serial connector used by the external modem:

Serial Connector for Data Circuit-terminating Equipment	Wiring
Nine-pin SUB-D female connector	TCS MCN 3M4M3S2 cable
25-pin SUB-D female connector	<ul style="list-style-type: none"> ● TCS MCN 3M4M3S2 cable ● TSX CTC 09 adapter

How to work with External Modem

Connection/Disconnection

After an external modem has been connected to a BMXNOR0200H module, use the website to configure the module.

The main feature of the modem is the possibility to work in Permanent mode or in On-Demand mode:

- Permanent mode: the connection is automatically performed when the BMXNOR0200H module is on power.
- On-Demand mode: the connection or disconnection is performed depending on the command register (*see page 77*).

Use the website to set a serial PPP connection.

NOTE: Do not forget to configure the serial port via the Website when the external modem is connected to it.

NOTE: GPRS MODEM does not support server mode.

Dialing

In practice, the Dial-in/Dial-out depends of the module mode. There are two different cases:

- The module is in Server/Slave mode: the modem connected to the module is in Dial-in mode.
- The module is in Client/Master mode: the modem connected to the module is in Dial-out mode.

Radio Modem User Cases

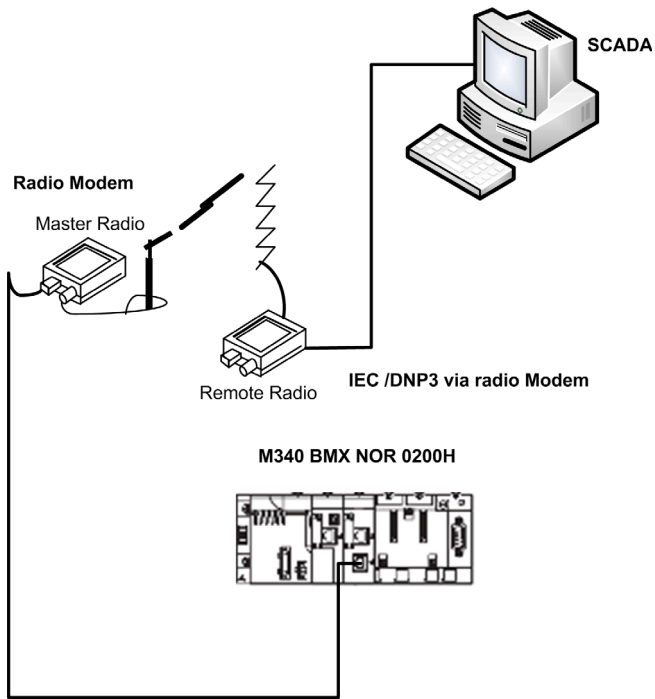

PSTN Modem User Cases

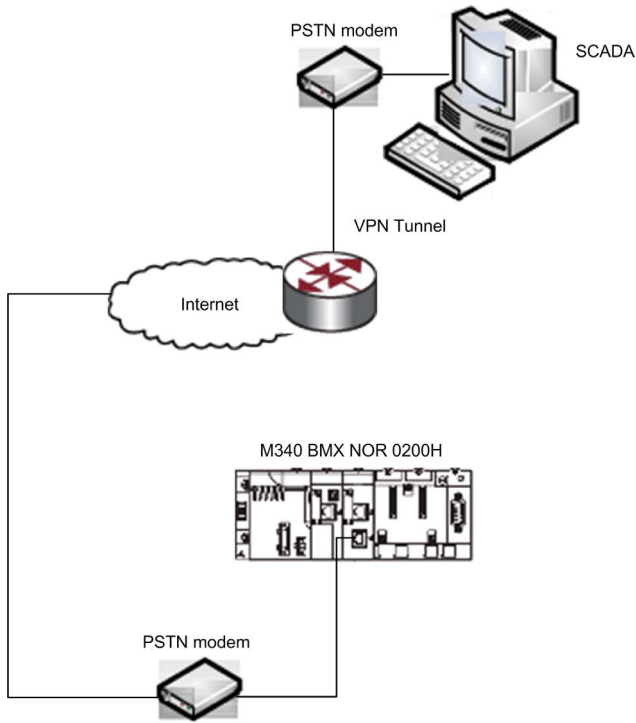

GPRS/GSM Modem User Cases

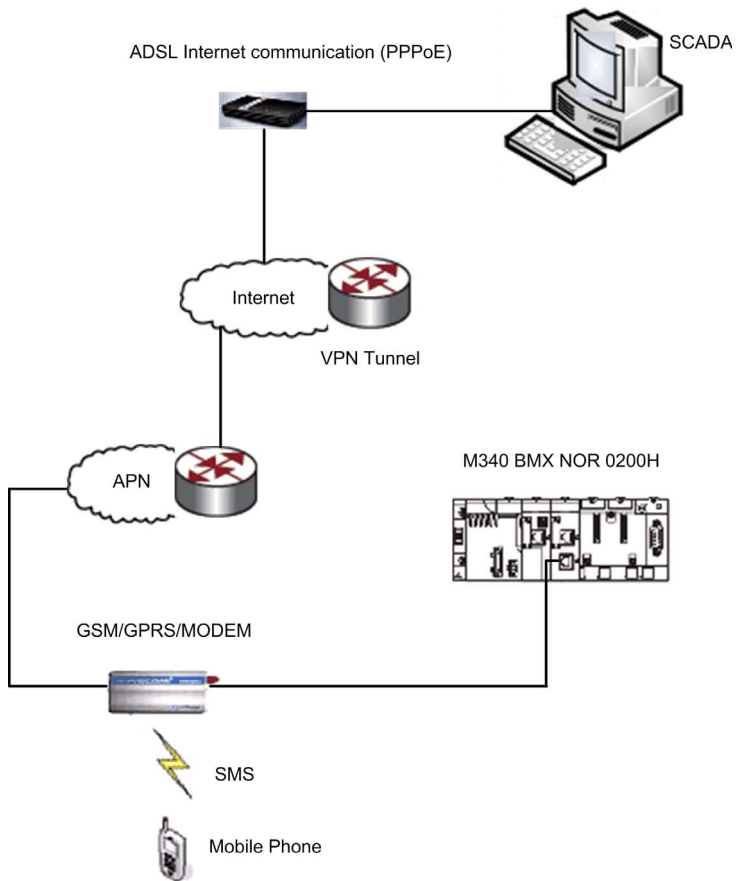

ADSL Modem User Cases

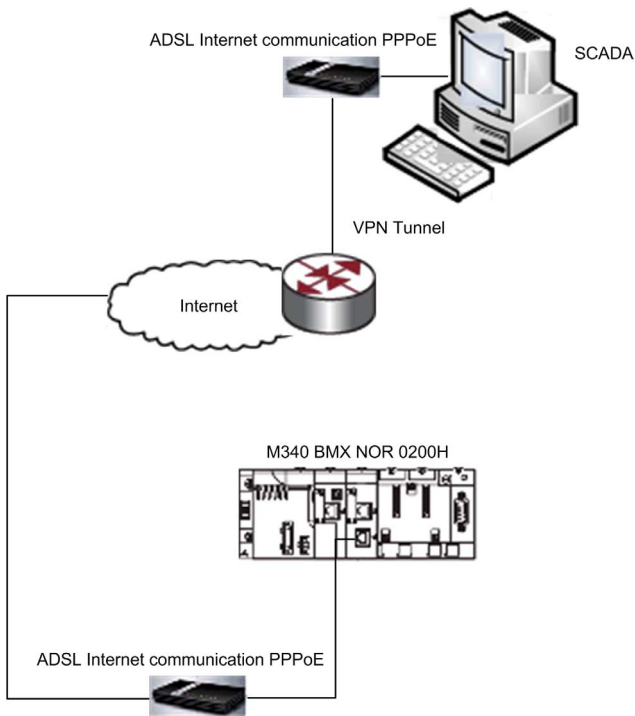

Part IV

Functional Description

Introduction

This part describes the functionality of the BMXNOR0200H module.

What Is in This Part?

This part contains the following chapters:

Chapter	Chapter Name	Page
7	How to Work with RTU Protocols	89
8	How to Work with Datalogging Service	125
9	How to Work with Email/SMS Service	137
10	How to Work with Embedded Web Pages	147

Chapter 7

How to Work with RTU Protocols

Introduction

This chapter describes the built-in RTU protocols characteristics for use in Telemetry and Supervisory Control and Data Acquisition (SCADA) applications.

What Is in This Chapter?

This chapter contains the following sections:

Section	Topic	Page
7.1	RTU Protocols	90
7.2	Clock Synchronization	96
7.3	Time Stamping	101
7.4	Events Management	102
7.5	Integrity Poll Command	114
7.6	Transmission Modes	117
7.7	Connection Status	122
7.8	Communication Error Codes	123

Section 7.1

RTU Protocols

What Is in This Section?

This section contains the following topics:

Topic	Page
Communication Protocols	91
IEC 60870-5-101/104 Protocols Overview	92
DNP3 Protocols Overview	94

Communication Protocols

Introduction

This topic describes the characteristics of the supported RTU protocols.

Functions and Protocols

The BMXNOR0200H module supports these functions and protocols:

RTU protocols	IEC 60870-5-101 (master or slave)
	IEC 60870-5-104 (client or server)
	DNP3 serial (master or slave)
	DNP3 NET (client or server)
Main RTU protocol features	time synchronization through a protocol facility or NTP
	balanced and unbalanced transmission mode
	events management with time stamping
	events queue stored in RAM memory (up to 100,000 events for all clients)
	events data backfill to SCADA application via protocol facility
	report by exception data exchanges
	unsolicited messaging data exchanges
protocol setup via webpage	

NOTE: The RTU protocol parameters are configured using the embedded webpages.

Limitations

The BMXNOR0200H module does not support multiple RTU protocols instances. Only one instance at a time of an RTU protocol (IEC, DNP3) can be launched to work with Modbus TCP.

NOTICE

UNINTENDED EQUIPMENT OPERATION

- Use different address values for each session in a channel or for each section in a session.
- Channel parameters must meet IEC60870-5-104 protocol requirements with these limitations:
 $T2 \text{ S Frame Period} < T1 \text{ Ack Period}$ and $W \text{ Value} < 2/3 \text{ K Value}$.
- If you are using the DNP3 protocol, use successive DB mapping starting at 0.

Failure to follow these instructions can result in equipment damage.

IEC 60870-5-101/104 Protocols Overview

Introduction

IEC 60870-5 is an international standard released in the early 1990s by the International Electrotechnical Commission (IEC). This standard provides a communication profile for telecontrol, teleprotection, and associated telecommunications characteristics for electric power systems. It is widely used today for other infrastructures, including water applications in Europe and Asia.

The IEC 60870-5-101 and IEC 60870-5-104 protocols are companions to the IEC 60870-5 standards that relate to transmission protocols.

IEC 60870-5-101

The IEC 60870-5-101 protocol is based on the EPA (Enhanced Performance Architecture). This protocol defines only the physical link and application layers of the OSI model. IEC 60870-5-101 is used primarily on serial links with relatively slow transmission media. This standard conforms to baud rates of up to 9600 bit/s, although much higher baud rates (<115200 bit/s) are being used.

IEC 60870-5-104

The IEC 60870-5-104 protocol is an extension of the IEC 60870-5-101 protocol. There are changes in transport, network, link & physical layer to open networking.

IEC 60870-5-104 enables communication between control stations and substations in a standard TCP/IP network. The TCP protocol is used for connection-oriented data transmission. To have connectivity to LANs and routers with different facilities (frame relay, etc.), connect it to the WAN. The application layer of IEC 104 is the same as that of IEC 60870-5-101, except that some data types and facilities are not used. There are separate link layers defined in the standard, which facilitates the transfer of data over Ethernet and serial lines.

Supported Protocol Features

Features of the IEC 60870-5-101/104 protocols:

- general interrogation
- clock synchronization
- events transmission (time-stamped or not)
- balanced and unbalanced communications
- counter interrogation
- command transmission modes (select and execute mode)

Supported Data Types

The IEC 60870-5-101/104 protocols include these data types:

- discrete inputs/outputs (single or double)
- measured values (with different formats)
- integrated totals
- commands

Protocol Characteristics

The table lists the characteristics for the supported RTU protocols:

Protocol	Characteristics
IEC 60870-5-101 master	up to 32 slaves (1 session for each slave and up to 5 sectors per session), individual database definition for each sector up to 5000-point database for all sectors including predefined commands
IEC 60870-5-101 slave	up to 5000- point database for data objects of all supported types up to 100,000-event queue for all data types supports clock synchronization from a master, CPU or NTP configurable data link address CAA (Common ASDU Address) and IOA event time-stamping configurable by type (None, CP24, CP56)
IEC 60870-5-104 server	client IP address validation list (up to 10 IP addresses) up to 4 concurrent client connections with configurable TCP service port (standard is 2404) up to 5000-point database for data objects of all supported types up to 100,000-event queue for all data types in all clients (each client has a dedicated event buffer) event time-stamping configurable by type (None, CP56) configurable CAA (common ASDU address) and IOA
IEC 60870-5-104 client	up to 5000-point database for all sectors including predefined commands up to 64 servers connections supported connections share common channel configuration dedicated connection for each session and sector configuration dedicated destination IP address and port settings for each connection

Interoperability Lists

The interoperability list (defined by the standard) facilitates interoperability between devices from different manufacturers. In the list, the function range is described for each device by marking the applicable functions.

NOTE: You can find BMXNOR0200H IEC interoperability list in Appendices. (*see page 332*)

DNP3 Protocols Overview

Introduction

The distributed network protocol (DNP3) protocol was developed to achieve an open, standard interoperability for communications between master stations, substation devices, RTUs, and Intelligent Electronic Devices (IEDs). DNP3 has been used primarily by utilities such as the electric power industry in North America and has become widely used in other distributed infrastructures such as water/wastewater, transportation and oil and gas industries.

DNP3 is based on the International Electrotechnical Commission Technical Committee 57 Working Group 03. The IEC TC57 WG03 has been working on the Enhanced Performance Architecture (EPA), a protocol standard for telecontrol applications. Each of the EPA's 3 layers corresponds to a layer on the OSI reference model.

DNP3 is specifically developed for inter-device communications that use SCADA RTUs. The protocol facilitates both RTU-to-IED (Intelligent Electronic Device) and master-to-RTU/IED.

The protocol was originally designed for slow serial communications, but the current DNP3 IP version also supports TCP/IP-based networking.

Supported Protocol Features

These are the main features that DNP3 supports:

- clock synchronization
- polled interrogations
- polled report-by-exception
- unsolicited report-by-exception
- events transmission (time-stamped or not)
- counter-specific treatment
- master commands

Supported Data Types

The DNP3 protocol includes these data types:

- discrete inputs/outputs (single or double)
- measured values (with different formats)
- integrated totals
- commands

Protocol Characteristics

The table lists the characteristics for the supported RTU protocols:

Protocol	Characteristics
DNP3 master/DNP3 NET client	up to 32 slaves/servers (1 session for each slave/server)
	up to 5000-point database for slaves data objects including predefined commands
DNP3 slave/DNP3 NET server	up to 5000-point database for data type objects
	up to 100,000-event queue for all data types
	supports clock synchronization from a master
	service over TCP
	4 concurrent client connections with configurable TCP service port (default port is 20000)

Interoperability Lists

This implementation of DNP3 is fully compliant with DNP3 Subset Definition Level 3, which suits larger RTU applications and offers practically the complete range of DNP3 functionality.

This standard defines interoperability between devices from different vendors. It includes a device profile that describes the basic protocol functionalities supported by the device and an Implementation table that defines information objects and their representation supported by the device.

Section 7.2

Clock Synchronization

Overview

The BMXNOR0200H module provides 2 ways to synchronize the clock with the SCADA (master) and the connected devices:

- via the RTU protocol facilities
- via the NTP protocol

NOTE: These clock synchronization methods are independent of one another. Configure your application to avoid clock synchronization conflicts.

The clock synchronization service establishes time accuracy among devices clocks over a network.

What Is in This Section?

This section contains the following topics:

Topic	Page
Clock Synchronization with the RTU Protocol Facilities	97
Clock Synchronization with the NTP Protocol	98

Clock Synchronization with the RTU Protocol Facilities

Overview

One of the main features of the RTU is to manage events with time stamping. Time stamping requires effective time synchronization.

Slave/Server

When acting as an IEC 60870-5-101/104 or DNP3 slave or server, the BMXNOR0200H module can synchronize its clock with a master or client station (SCADA). When the module receives the clock synchronization command, it updates its internal clock and posts the new value to the CPU. This maintains a consistent time on the local rack.

Master/Client

When acting as an IEC 60870-5-101/104 or DNP3 master or client, the BMXNOR0200H module sends clock synchronization commands to connected slaves. As with the case above, the clock is initialized from the CPU when it starts up. It gets the new time from the CPU every time master/client sends the time synchronization command.

NOTE: In a Modicon M580 PAC, it is mandatory to enable the NTP client to use the BMXNOR0200H module.

Slave/Server and Master/Client

When acting as both a master/client or slave/server, the BMXNOR0200H module periodically synchronizes its local time with that of the CPU through the rack.

Clock Synchronization with the NTP Protocol

Features of the Service

The clock synchronization via NTP offers:

- periodic time corrections obtained from the reference standard, for example, the NTP server
- automatic switchover to a backup time server if a trouble occurs with the normal server system
- local time zone configurable and customizable (including daylight saving time adjustments)

Controller projects use a function block to read the clock, a feature that allows events or variables in the project to be time stamped.

Time stamping is accurate to:

- 5 ms typical
- 10 ms worst case

Clock Synchronization and Time Stamps

The BMXNOR0200H module sends a source clock synchronization signal to the CPU. The module firmware includes an NTP client, which provides clock synchronization. The synchronization process occurs as follows:

The NTP Client...		Result
1	... requests a clock synchronization signal from the NTP server over an Ethernet network.	The NTP server sends a signal.
2	... stores the time.	
3	... sends a message to the clock system counter in the CPU.	The CPU updates its internal clock. The CPU clock is now typically within 5 ms of the NTP server, with a worst case of 10 ms. Before the next clock synchronization signal, the CPU clock is updated each ms by an internal timer.

Use the R_NTPTC function block (*see EcoStruxure™ Control Expert, System, Block Library*) in either MAST, FAST, or Interrupt sections to read the clock from the PLC application.

The CPUs on an Ethernet network should be synchronized with the same NTP server.

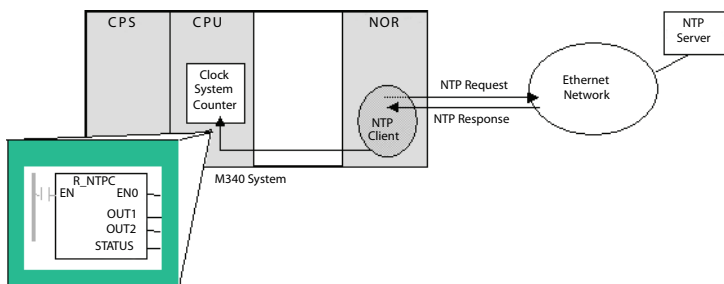

Clock Synchronization Terms

Term	Description of Service
local clock offset	<p>Accurate local time adjustments are made via a local clock offset. The local clock offset is calculated as:</p> $((T2 - T1) + (T4 - T3)) / 2$ <p>where:</p> <ul style="list-style-type: none"> ● T1 = time when NTP request is transmitted from the module ● T2 = time when NTP server receives the request (provided by the module in response) ● T3 = time when the NTP server transmits the response (provided to the module in the response) ● T4 = time when NTP response is received by the module
time accuracy	<p>The local time margin is < 10 ms compared to the referenced NTP server time.</p> <ul style="list-style-type: none"> ● typical: 5 ms ● worst case: <10 ms
settling time	Maximum accuracy is obtained after 2 updates from the NTP server.
polling period dependency	Accuracy depends on the polling period. Less than 10 ms of margin is achieved for polling periods of 120 ms or less. To obtain a high degree of accuracy (when your network bandwidth allows), reduce the polling period to a small value—for example, a polling time of 5 s provides better accuracy than a time of 30 s.
time zone	The default format is universal time, coordinated (UTC). Optionally you may configure the service to use a local time zone—e.g., GMT+1 for Barcelona or Paris
daylight saving time	The module automatically adjusts the time change in the spring and fall.
leap second	<p>To compensate for the deceleration of the earth rotation, the module automatically inserts a leap second in the UTC time every 18 months via an international earth rotation service (IERS).</p> <p>Leap seconds are inserted automatically as needed. When needed, they are inserted at the end of the last minute in June or December, as commanded by the NTP server.</p>

Obtaining and Maintaining Accuracy

The time service clock starts at 0 and increments until the Ethernet network time is fully updated from the module.

Model	Starting Date
M340 with Control Expert	January 1, 1980 00:00:00.00

Clock characteristics:

- Clock accuracy is not affected by issuing stop/run commands on the PLC
- Clock updates are not affected by issuing stop/run commands on the PLC
- Mode transitions do not affect the accuracy of the Ethernet network

Re initializing the Time Service Register

After a download or an NTP server swap, the status clock value associated with the time service register in the CPU is re initialized.

Two polling periods elapse before an accurate time is re-established.

Section 7.3

Time Stamping

Event Time Stamping

Overview

BMXNOR0200H module provides two ways for time stamping of events:

- Time stamping done at source in the CPU (requires PLC programming).
- Time stamping done in the RTU module (no PLC programming required).

NOTE: Improved time stamping resolution can be obtained when performing the time stamping in the PLC CPU. Time stamping resolution is basically depending on the CPU scan time and I/O modules type.

Supported Time Formats

In IEC 101 the *Time Format* for events time stamping may be set to one of the following options:

- CP56: 56-bit (default)
- CP24: 24-bit

The 56-bit *Time Format* is an absolute time format, whereas the 24-bit *Time Format* is an incremental time format that only specifies minutes and milliseconds. The IEC 104 protocol uses 56-bit time format.

Section 7.4

Events Management

What Is in This Section?

This section contains the following topics:

Topic	Page
Overview	103
Events Routing	106
Events Backup	111

Overview

Introduction

The BMXNOR0200H module generates events on changes of state, handles events lists and provides the following services:

- The management of a buffer of events (time stamped or not), overall buffer (queue) size can be up to 100,000 events (the maximum value is 100,000 from RTU 1.5).

NOTE: One dedicated event buffer is managed per client/master application (up to 4 client/master applications are supported).

- Automatic event backfill to the SCADA or the master station via RTU protocol facility (on DNP3 and IEC 101/104).

For RTU slave configuration (DNP3 slave, IEC 60870-5-101 slave and IEC 60870-5-104 server), each object type has an independent event queue setting. To generate an event, set an event queue for the corresponding object type.

Event Generation

A dialog box is used to configure the event generation:

Object Group

The 'Clear_Events' dialog box is shown with the 'Object Group' dropdown menu open. The options listed are: All Objects, Binary Input, Double Input, Binary Counter, Analog Input, Binary Output, and Analog Output.

Point Count

The 'Gen_Events' dialog box is shown with the following configuration:

- Object Group: Binary Input
- Start Point Number: 0
- Point Count: 5000
- CPU Register Type: %MW
- CPU Register Address: 0
- Variable Name: -

Parameter Description: Number of points to generate events, the maximal value(5000) means infinite point count (Min: 1, Max: 5000, Default: 5000)

Event Queue Setting Page

The user can map event queue status to CPU registers. The status for each event queue is a 32-bit register (2 words in CPU). A higher word 1 means the event queue has overflowed. The lower word is the number of events in the event queue.

From the Web site, select event mapping:

The screenshot displays the 'Event Queue Setting Page' for an IEC-104 Server. On the left, a navigation tree is visible with the following structure:

- Setup
 - Communication
 - Channel Parameters
 - Modem
 - Parameters
 - Modem GSM
 - Phone List
 - Serial Port
 - Parameters
 - PPPoE
 - Parameters
 - Channel
 - IEC-104 Server
 - Parameters
 - Session 0
 - Parameters
 - Sector 0
 - Parameters
 - Data Mapping
 - Events
 - Reset Communication
 - Export/Import files
 - Security
 - FTP

The main content area is titled 'IEC-104 Server(Channel0 Session0 Sector0) - Events'. It features a table with the following columns: 'Type Identification', 'Event Store Mode', 'Max Event Count', 'CPU Reg Type', and 'CPU Reg Address'. A 'Remove' button is located at the top left of the table. A dropdown menu is open, showing a list of event types: M_SP, M_DP, M_ST, M_BO, M_ME_A, M_ME_B, M_ME_C, and M_IT. An 'Add' button is positioned at the bottom right of the table area.

NOTE: When the events number exceeds the configured buffer size, events will be lost or overwritten.

Increasing Maximal Event Buffer Size

You can increase the maximum events buffer size from 10,000 to 100,000 (in case of one client connection).

NOTE: All channels can support up to 100,000 events, but each point type only supports up to 65,535 events.

A dialog box is used to configure the maximum event count:

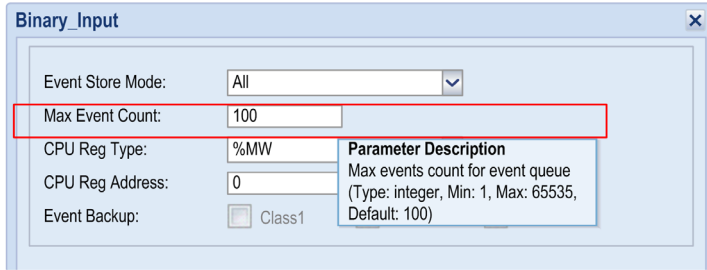

The screenshot shows a dialog box titled "Binary Input" with a close button (X) in the top right corner. The dialog contains several configuration fields:

- Event Store Mode: All (dropdown menu)
- Max Event Count: 100 (text input field, highlighted with a red box)
- CPU Reg Type: %MW (text input field)
- CPU Reg Address: 0 (text input field)
- Event Backup: Class1 (checkbox and text)

A "Parameter Description" box is visible on the right side of the dialog, containing the following text:

Parameter Description
Max events count for event queue
(Type: integer, Min: 1, Max: 65535,
Default: 100)

Events Routing

Introduction

The events routing component allows events from sub stations to be routed to SCADA within one BMXNOR0200H module.

To route events, one RTU master channel and at least one RTU slave channel are needed inside the system. The solution is to create a logic RTU master and slave in a single BMXNOR0200H module. In the logic master, points are created to represent points in sub stations, and in the logic slave, points are created to simulate the behavior of points in sub stations. Events routing component is responsible for collecting events in the logic master. These events are sent from sub stations, and trigger the same events in the logic slave.

BMXNOR0200H module components:

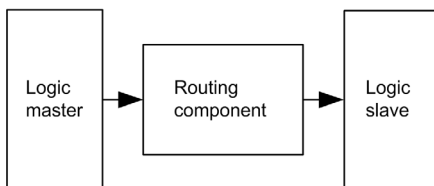

NOTE: Routing capabilities are only possible within a single module.

There are no automatic routing capabilities between two BMXNOR0200H modules (a slave/server and a master) configured in the same station.

In a hierarchical architecture, time stamped events are automatically transferred from low end slave sub stations to the SCADA (or master) through the station. The automatic transfer uses path-through events functionality with a single BMXNOR0200H module configured in both slave and master.

Configuration

Configure the BMXNOR0200H module for event routing. Most of the BMXNOR0200H module parameters are configured via webpages as are the event routing functions. There is no dedicated webpage for the events routing function, this function is configured inside the data mapping configuration pages.

NOTE: The BMXNOR0200H does not detect events for the routing points in slave.

NOTE: With the loss of power management, you can specify in the configuration if you want to poll more events from the BMXNOR0200H modules, fallback to SCADA and prevent events from being lost.

Channel Configuration

For routing events, configure one master channel and at least one slave channel. One master channel is required so that the system can connect with more sub slaves, and more slave channels allow for more SCADA in the system.

Communication Channel Parameters								
Remove Add								
Channel ID	Protocol	Mode	Network Type	IP Address	Port	Count Channels	CPU Reg Type	Connection Status Address
0	DNP3	Master(Client)	TCP-IP			1	%MW	0
1	DNP3	Slave(Server)	TCP-IP	255.255.255.255	20000	1	%MW	2000

Master Data Mapping Configuration

You must first add data points in the master channel. These points represent points in the sub slave which communicate with the master channel.

Master points mapping:

Channel1 Session0-Data Mapping					
Remove					
Type Identification	Point Number	Data Count	CPU Point Type	CPU Point Address	
Binary_Input	0	10	%MW	10	
Double_Input	0	5	%MW	20	
Analog_Input	0	10	%MW	30	

When configuring these points in the master channel, select the events of the point which needs to be routed, and route events to the corresponding slave channel.

For example, if the master channel needs to receive events from the sub slave Binary Input point, routed it to the logic slave channel and so that becomes an event of the Binary Input point.

Master points configuration:

The screenshot shows a configuration window titled "Binary_Input". It contains the following fields and options:

- Point Number: 10
- Point Count: 1
- CPU Register Type: %MW
- CPU Register Address: 0
- Variable Name: -
- Store To CPU: Value only
- Static Variation: g1v1 Binary In
- Event routing** section:
 - Channel: 1
 - Session: 0
 - Point Number: 0
 - Event Class Mask: Class0 Class1 Class2 Class3
 - Default Event Variation: g2v1 Binary Input No Tin

NOTE:

- When the user specifies one point in the master for event routing such as the binary input point, one corresponding point configuration is automatically generated in the logic slave channel. The point configuration is read only in the logic slave channel, and cannot be changed or removed in its DB mapping panel.
- If the channel number, session number, or point number mismatches in the slave channel, an error page appears.
- If the user chooses the route to the channel as None, this means that this point does not need to be routed to a slave.

Slave Points Configuration

After configuring the points in the master channel, the corresponding point is listed in the slave channel.

Slave points mapping:

DNP3 NET Server(Channel1 Session0) – Data Mapping					
Remove					
Type Identification	Point Number	Data Count	CPU Point Type	CPU Point Address	
Binary_Input	0	10	%MW	100	
Double_Input	0	5	%MW	200	
Analog_Input	0	1	%MW	300	

The points used to route are different from the normal points of the slave. The parameters (CPU type, CPU address, variable name, and time stamp) of CPU mapping are no longer available, and the available parameters are read only. **Their lifetime is consistent with peer point configuration in the master.**

Slave points configuration:

Binary_Input ✕

Point Number:

Point Count:

Event Class Mask: Class0 Class1 Class2 Class3

Default Static Variation: ▼

Default Event Variation: ▼

Channel Combination for Events Routing

To route events inside the BMXNOR0200H module, follow the configuration instructions (*see page 106*) to combine the master channel and slave channel.

The supported combinations are:

Master channel	Slave channel
DNP3 net client	DNP3 net server
DNP3 serial master	DNP3 net server
IEC-104 client IEC-101 master	IEC-104 server IEC-104 server

Limitations

- Events are routed inside the module. This means that it is not possible to route events between two or more modules and also that the PLC application in the CPU cannot get and process the events (the CPU can still get the point value in events just like the standalone master channel).
- Events and static points are routed. Requests (commands) from SCADA are not routed to the sub slave. This means that inside the BMXNOR0200H module, there is no other data exchange or communication between the master channel and the slave channel except for events.
- Not all master and slave channel combinations are supported by the routing function (*see page 106*).
- In the system, SCADA cannot communicate with sub slaves. The solution uses the logic slave in the BMXNOR0200H module to simulate sub slaves, so SCADA can only communicate with the logic the slave in the BMXNOR0200H module, and sub slave can only communicate with the logic master in BMXNOR0200H module.
- Some information related to events may be changed. Key information related to events like point value, flag, and timestamp is kept during routing. Other information related to events like point number, events class, and variation is changed according to the slave channel configuration.

Events Buffer Size

The events buffer of the slave must be greater than the events buffer in the sub slave otherwise events are lost.

Events Backup

Introduction

The BMXNOR0200H and RTU protocol have a maximal number of events buffer size of 100,000.

NOTE: The BMXNOR0200H module supports the backup of up to 10,000 events into Flash memory on loss of power. Only the latest events are saved if the number of events is more than 10,000.

The event monitor component:

- saves up to 10,000 events into Flash memory on loss of power,
- reads events from the Flash memory when power is restored,
- saves only the latest events if the size of the saved events exceeds 10,000,
- can be configured to decide which events or data types need to be saved on loss of power.

Web Configuration

Event backup is a configurable feature for users. It can be enabled or disabled on the Web site as shown in the picture below and it is disabled by default. This feature is set individually for each channel and each data type. Only the events of the main channel are saved on loss of power. After power restoration, the saved events can be restored into the main channel, and also the virtual channels, which depend on Event Restore Mode configuration in the Web site. These configurations take effect after a communication reset in the Web site or power recycle.

Configuration of event backup:

The screenshot shows a web configuration window titled "DNP3 NET Server(Channel0)". Under the "Parameters" section, the following settings are visible:

- Event Backup Enable:
- Event Restore Mode: All Channels (dropdown menu)
- EventS Time Quality: Original Quality (dropdown menu)

Below these settings, a red warning message reads: "Event backup feature is not supported by PV: 01 02 05 06". At the bottom of the window, there is a "Change" button and a section for "Advanced Parameters" which is currently collapsed.

Event restore mode:

- **Event backup enable:** Specifies whether the channel (IEC or DNP3 server/slave) supports event backup if the module does not power up. It is only effective for the main channel.
- **Event restore mode:** It has two options, main channel and all channels. Select the main channel option if you want to add saved events into the event buffer of the main channel when power restores, ignoring the virtual channel. Select the option all channels if you want to add saved events into both the main channel and virtual channels when power restores.

Events Time Quality: When restoring backup events after power restoration, the time quality is forced to

- **invalid with Forcing Invalid**
- **the original quality with Original Quality**

NOTE: The box Event Backup Enable must be checked beforehand.

Configuration of event backup for DNP3:

The screenshot shows a configuration window titled 'Analog_Input'. It contains several settings: 'Event Store Mode' set to 'All', 'Max Event Count' set to '100', 'CPU Reg Type' set to '%MW', and 'CPU Reg Address' set to '0'. At the bottom, the 'Event Backup' section is highlighted with a red box and contains three unchecked checkboxes labeled 'Class1', 'Class2', and 'Class3'.

Configuration of event backup for IEC 101 and IEC 104:

The screenshot shows a configuration window titled 'M_SP Single-point information'. It contains several settings: 'Event Store Mode' set to 'All', 'Time Stamp Type' set to 'CP56', 'Max Event Count' set to '100', 'CPU Reg Type' set to '%MW', and 'CPU Reg Address' set to '0'. At the bottom, the 'Event Backup' checkbox is unchecked.

NOTE: When restoring events from the Flash into the event buffer after power restores, the BMXNOR0200H module sorts the events according to the timestamps of the events.

Event Backup Behavior

The RTU has different backup behaviors in different cases. The type of case is defined from the user point view:

	Case		Event
1	Loss of power	power lost	Saves events in non volatile memory on loss of power
2	Power start	power on/restore	Restores events when the RTU protocol starts
3	Protocol exit	Unity Pro Ethernet configuration resets RTU communication through Web site RTU protocol cold/warm restart.	Does not save events when the protocol exits

Signature Authentication

Signature authentication is required when events are restored from the Flash memory. It checks if the protocol configuration has changed during the power loss and restore. If the signature of the XML configuration is different from the record in the Flash, all the events are deleted directly.

NOTE: The signature changes if the parameters of the channel/session/sector or Network Type/IP/Port/Start Reg Addr/Connection Count have changed. The Modem/PPPoE/Serial Port/Time Zone do not have an effect on the signature.

Limitations

If the events number to save exceeds the size of the Flash memory, the BMXNOR0200H module saves only the latest events.

Section 7.5

Integrity Poll Command

Integrity Poll Command

Introduction

Command DNP3 and Integrity Poll: Integrity poll retrieves all event (class 123) and static (Class 0) data from the device. It is typically sent after device restart, loss of communication, or on a periodic basis to check data accuracy.

Command IEC and General Interrogation: The General Interrogation command retrieves all or a specified group of static data. It is typically sent after device restart, loss of communication, or on a periodic basis so that no changes are missed in the spontaneous data reporting.

Communication Behavior

The BMXNOR0200H module has three communication ports, one serial port, one Ethernet port, and a backplane interface.

The serial port and the Ethernet port are mainly used to communicate with the remote master or slaves with RTU protocols. The backplane interface is used to communicate with the CPU. The main activity of the backplane interface is synchronizing data between CPU registers and the RTU point database inside the module. The synchronization cycle can be one or more PLC application scan cycles, depending on the data amount and backplane load.

When Master Channel Receives Events from Sub Slave

When something significant changes in sub slave, such as a value of a point, the sub slave sent out an event. The system receives this event and the event needs to be routed to SCADA system.

Events routing example:

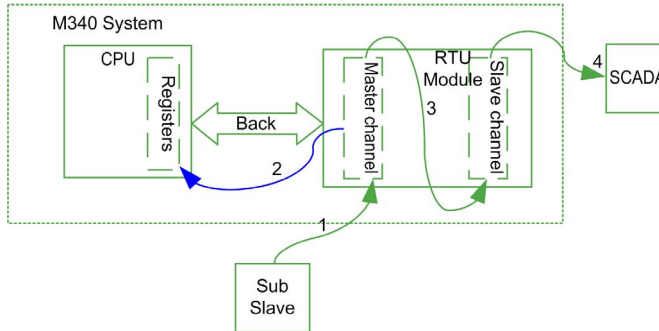

- 1 Sub slave sends out events to the master channel.
- 2 Master channel updates the point values in the module and the database of the logic slave channel and synchronizes the value to CPU registers.
- 3 Events are routed to slave channels according to point configuration.
- 4 Slave channel buffers these events and sends events to SCADA if communication link is established.

When Slave Channel Receives Request from SCADA

In the RTU system, SCADA sends requests (commands) like an Integrity Poll to slaves connected to it. The slave channel receives this request and sends a response to SCADA. In the routing system, the behavior of the slave channel is exactly the same as a standalone (without events routing) slave channel. The master channel and sub slaves are not involved in this case.

Response to the request from SCADA example:

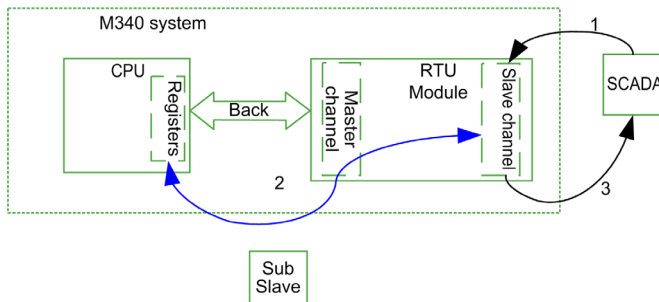

- 1 SCADA sends an Integrity Poll request to the slave channel.
- 2 Points values are synchronized cyclically between the database of the slave channel and CPU registers.
- 3 The slave channel responds to the SCADA request with the points value in the database.

When Master Channel Sends Request to Sub Slave

The master channel can send requests to a sub slave connected to it, and a sub slave sends the response back to as the master channel. The behavior of the master channel in this case is exactly the same as a standalone master channel. **The points in the logic slave channel should be synchronized with the updated point in the master channel.**

Send request to sub slave example:

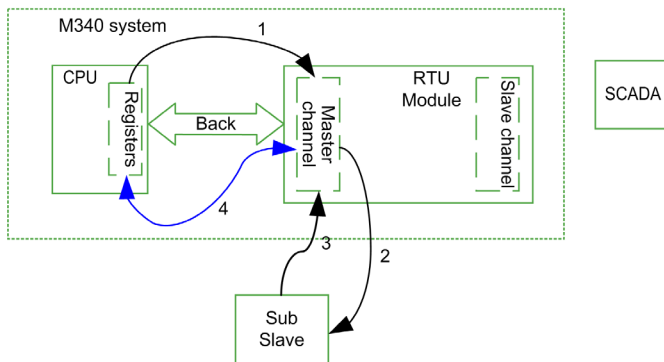

- 1 PLC application in the M340 CPU sends a Integrity Poll command to the master channel.
- 2 The master channel send Integrity Poll request to the sub slave.
- 3 The sub slave responds to the request with the value of the latest points.
- 4 The logic slave data base is synchronized while the master channel updates the database.
- 5 Points value are synchronized cyclically between the database of the master channel and CPU registers.

Section 7.6

Transmission Modes

Overview

Introduction

With DNP3 or IEC101/104 protocols, the BMXNOR0200H module manages different ways of retrieving data with the following transmission modes:

- balanced or unbalanced transmissions
- polled interrogations
- report by exception
- unsolicited messaging
- mix of the above methods

NOTE: For transmission modes setup, set the Advanced Parameters (*see page 277*) (DNP3).

Balanced and Unbalanced Mode

In the unbalanced transmission mode only the master station can initiate data transfer with the remote devices by polling the slaves. In balanced transmission mode, both the master and slaves can initiate data transfer.

Polled Interrogations

Polled Interrogations is the basic data exchange method. The master station requests data to multiple RTU station devices by polling periodically the remote slaves.

Report by Exception

Report By Exception (RBE) provides optimized data transfer between master and slaves stations, where only changes of data are reported, whereas in Polled Interrogations - the master station periodically requests data to the slaves devices. RBE is particularly useful when using low rate communication media (PSTN, GSM/GPRS) by reducing traffic overhead and transmission costs.

Unsolicited Messaging

Unsolicited Messaging is the basic data exchange method. The slave station initiates data transmission even though the master station does not send poll interrogations.

Parameters Dependency Link

Parameter dependency link table for IEC101/104:

Transmission Mode	Parameter Dependency	Parameter Location	Relationship With Transmission Mode
Balanced and Unbalanced Mode	Used Balanced Mode	IEC-101 Slave/Channel/	Unbalanced transmission mode: only IEC101 master station can initiate data transferring with the remote devices by polling the slave. It means that slave keep silent unless master request its response. RBE is not recommended to use under this mode.
			Balanced transmission: both the master and slaves can initiate data transfer. IEC104 support balanced mode by default thanks to TCP/IP.
Polled Interrogations	Groups	IEC-101 Slave / Channel/Session/Sector/ Data Mapping/M_xxx	It is to set group attributes of monitoring point. It is used to respond to the general Interrogations with specific group of static data.
		IEC-104 Server / Channel/Session/Sector/ Data Mapping/M_xxx	
	Read Time Format	IEC-101 Slave / Channel/Session/Sector/ Parameter	It is used to specify the time stamp format in the response to read command. NOTE: It is used for the points except measured points and counter.
		IEC-104 Server / Channel/Session/Sector/ Parameter	
	C_RD_NA Measure and Time Format	IEC-101 Slave / Channel/Session/Sector/ Parameter	It is used to specify the time stamp format in the response to read command. NOTE: It is used for measured points
		IEC-104 Server / Channel/Session/Sector/ Parameter	
	C_IC_NA Time Format	IEC-101 Slave / Channel/Session/Sector/ Parameter	It is used to specify the time stamp format in the response to read command. NOTE: It is used for counter.
		IEC-104 Server / Channel/Session/Sector/ Parameter	

Transmission Mode	Parameter Dependency	Parameter Location	Relationship With Transmission Mode
Report By Exception	Max Event Count	IEC-101 Slave / Channel/Session/Sector/ Events/M_xxx	Event count is disabled by default. It is required to set explicitly for RBE. When Event count is more than 0, BMXNOR0200H save events into local buffer. After connection is ON Line, the event is reported automatically.
		IEC-104 Server / Channel/Session/Sector/ Events/M_xxx	
	Delete Oldest Event	IEC-101 Slave / Channel/Session/Sector/ Advanced Parameter	It is used to manage event buffer overflow. Delete the oldest one or newest one when buffer overflow.
		IEC-104 Server / Channel/Session/Sector/ Advanced Parameter	
	Event Generation	IEC-101 Slave / Channel/Session/Sector/ Data Mapping/M_xxx	It is used to specify whether this point is reported as event or not. NOTE: It must be checked for RBE. This feature is available for BMXNOR0200H module firmwareV1.7 or later.
		IEC-104 Server / Channel/Session/Sector/ Data Mapping/M_xxx	

Parameter dependency link table for DNP3:

Transmission Mode	Parameter Dependency	Parameter Location	Relationship With Transmission Mode
Balanced and Unbalanced Mode	Unsolicited Message feature	–	DNP3 support balanced mode by default for both DNP3 and DNP3 NET. When DNP3 over Serial Line, master need manage to enable/disable the unsolicited message. In general, keep unsolicited message managed by master or disabled if master has multiple slave communicated over serial line.
			When DNP3 over TCP/IP, no such strict ion on the management of unsolicited message thanks to TCP/IP.
Polled Interrogations	Event Class Mask	DNP3 Slave / Channel/Session/ Data Mapping/{Binary input/output/counter, Analog input/output}	It is mandatory to enable Class 0 to respond to Integrity Poll of controlling station. NOTE: It is possible to read all data through Read Group no matter what class it is assigned.
		DNP3 NET Server / Channel/Session/ Data Mapping/{Binary input/output/counter, Analog input/output}	

Transmission Mode	Parameter Dependency	Parameter Location	Relationship With Transmission Mode
Unsolicited Message (Report By Exception)	Unsol Allowed	DNP3 Slave / Channel/Session/ Advanced Parameter	It is used to enable/disable unsolicited message by controlling station.
		DNP3 NET Server / Channel/Session/ Advanced Parameter	For unsolicited message, it must be enabled. Unselected <code>Unsol Allowed</code> is to control not to report event as unsolicited message, but the events are able to report for integrity poll and read group.
	Max Event Count	DNP3 Slave / Channel/Session/ Events /{Binary input/output/counter, Analog input/output}	Event count is disabled by default. It must be set as enabled explicitly for unsolicited message. When Event count is more than 0, <code>BMXNOR0200H</code> saves events into local buffer which are able to report as unsolicited message if unsolicited message is enabled, or respond to integrity poll and read group.
		DNP3 NET Server / Channel/Session/ Events /{Binary input/output/counter, Analog input/output}	
	Delete Oldest Event	DNP3 Slave / Channel/Session/ Advanced Parameter	It is used to manage event buffer overflow. Delete the oldest one or newest one when buffer overflow.
		DNP3 NET Server / Channel/Session/ Advanced Parameter	

Transmission Mode	Parameter Dependency	Parameter Location	Relationship With Transmission Mode
Unsolicited Message (Report By Exception)	Event Class Mask	DNP3 Slave / Channel/Session/ Data Mapping/{Binary input/output/counter, Analog input/output}	It is mandatory to assign one of Class 1,2,3 and Unsolicited for unsolicited message. BMXNOR0200H initiates unsolicited messages as class according to unsolicited message enabled by controlling station. NOTE: It is possible to read all events through Integrity Poll/Read Group no matter whether unsolicited message is enabled or not.
		DNP3 NET Server / Channel/Session/ Data Mapping/{Binary input/output/counter, Analog input/output}	
	Unsol Class x Max Event {x=1,2,3}	DNP3 Slave / Channel/Session/ Advanced Parameter	It is used to specify the maximal number of events in the corresponding class to be allowed before an unsolicited response is generated if unsolicited message is enabled. NOTE: Once one class matches the maximal number of events, the events of all classes enabled are sent out.
		DNP3 NET Server / Channel/Session/ Advanced Parameter	
	Unsol Class x Max Delay {x=1,2,3}	DNP3 Slave / Channel/Session/ Advanced Parameter	It is used to specify the maximal amount of time after an event in the corresponding class is received before an unsolicited response is generated if unsolicited message is enabled. NOTE: Once one class matches the maximal amount of time after event generation, the events of all classes enabled are sent out.
		DNP3 NET Server / Channel/Session/ Advanced Parameter	

Section 7.7

Connection Status

Overview

Introduction

The connection status of each channel of the module is put in a double-word descriptor that is mapped to the CPU memory of your PLC program facility.

Word Mapping

You assign a valid CPU memory address to which the connection status descriptor is to be mapped.

NOTE: For IEC 60870-5-104 and DNP3 server witch configured to connect with more than one client, each client has an independent connection status, and they store in sequence in CPU memory.

The descriptor occupies 2 consecutive CPU memory words. The following tables show the information that the connection status descriptor contains.

Bit 31	Bit 30...Bit 1	Bit 0
Session #31	session #30...session #1	session #0

For the IEC 60870-5-101in balanced mode and the DNP protocol, the connection status descriptors are set to 1 to indicate that all slaves are connected. Then the corresponding bit is reset to 0 after the command is sent without the reception of a valid response.

NOTE: If connection status really matters, configure parameter "Test Frame Period" with a none zero value for IEC 60870-5-101 protocol, "Link Status Period" for DNP3 protocol

Section 7.8

Communication Error Codes

RTU Protocols Communication Error Codes

Introduction

In order to diagnose RTU communication, error codes are available in RTU diagnostic Web page.

Error Codes

The table below describes the RTU protocols communication error codes:

Value	Definition
00000001 hex	Total count of data points in all channels exceeds 5000.
00000002 hex	Total count of data points' event in one protocol exceeds 100,000.
00000004 hex	The accessed register (M%, %S, MW%, %SW) address exceeds CPU register's range.
00000008 hex	The size of unlocated variable / array exceeds 1000 bytes.
00010000 hex	Unlocated variable is not defined in CPU.
00020000 hex	Time zone collision between NTP and RTU.
01000000 hex	Data base of RTU protocol is not initialized successfully.

Chapter 8

How to Work with Datalogging Service

Introduction

This chapter describes the Datalogging Service and explains how to configure it.

What Is in This Chapter?

This chapter contains the following topics:

Topic	Page
About Datalogging Service	126
Create a Datalogging Service	128
Datalogging Properties	129
Datalogging Configuration	131
Datalogging File Format	135
Recommendation on Datalogging Service	136

About Datalogging Service

Service Description

The datalogging service allows application data archiving (events, alarms, process data, devices status, measures, etc.) in the internal memory of the BMXNOR0200H module. This service allows you to log data into CSV files in the ASCII format. CSV files are stored locally in the SD memory card of the BMXNOR0200H module.

Datalogging can be performed either periodically or when a specific event (configured by the user) occurs. CSV files are directly usable by an MS Excel spreadsheet or a database management system (DBMS). The CSV files can also be sent through FTP or attached to an email (using the email service) that is automatically sent to specified users. CSV files can also be accessed by an FTP client.

Any FTP client can access the module's file system. You can specify a URL to automatically send information to a remote FTP server.

NOTE: The datalogging service is configured using Web Designer software.

Service Principles

Datalogging is performed in the RAM memory of the BMXNOR0200H module to backup the SD card memory.

The datalogging service can manage up to 10 groups of datalogging files (tables). This allows for the archiving of several different tables of data, each associated with a different logging period.

Datalogging files can be backed up, periodically or on event, from the RAM memory to non-volatile memory of the module (on the SD memory card) into history files in the CSV format. For example, `Table_n.csv` represents the last backup file, and history files are renamed as `Table_n.cs0`, `Table_n.cs1`, etc.

CSV files can be purged on the SD memory card by an event trigger.

Characteristics

Remember:

- To prolong the life of the SD card, Schneider-Electric recommends you not to backup datalogging files more frequently than every 30 minutes.
- The time that each data logging instance occurs is not precise.
- Back up any log files that are stored in the module's volatile memory to enable the restoration of lost data.
- When power is lost during datalogging, the file that is being backed up is lost.

Datalogging Service Codes

Value	Comment
0	OK
2	The current file '.csv' is renamed '.cs0'.
10	The module cannot reach a variable that should be logged because: <ul style="list-style-type: none"> the variable does not appear in the namespace. the variable is not write enabled. the preceding value has not been updated yet.
11	FTP transfer interruption.
12	The URL specified for FTP cannot be accessed.
13	The internal flash is full.
14	The internal RAM is full.
15	The module cannot write on the media specified.
16	The module cannot access the namespace.
17	The maximum number of tables has been reached (10 maximum) in your <i>.xml</i> file.
18	The maximum number of variables has been reached in a table.
19	The service is empty, no table defined.

NOTE:

- The datalogging service code 2 should be considered as a status.
- The highest values have the priority. The datalogging service code 17 has priority over the datalogging service code 12. When the datalogging service code 17 has been corrected, the datalogging service code 12 can then be sent to the variable declared for the status of the database service
- The values of the table status variable are identical to the values of the datalogging service status variable.

Create a Datalogging Service

Procedure

Follow these steps to create a datalogging service:

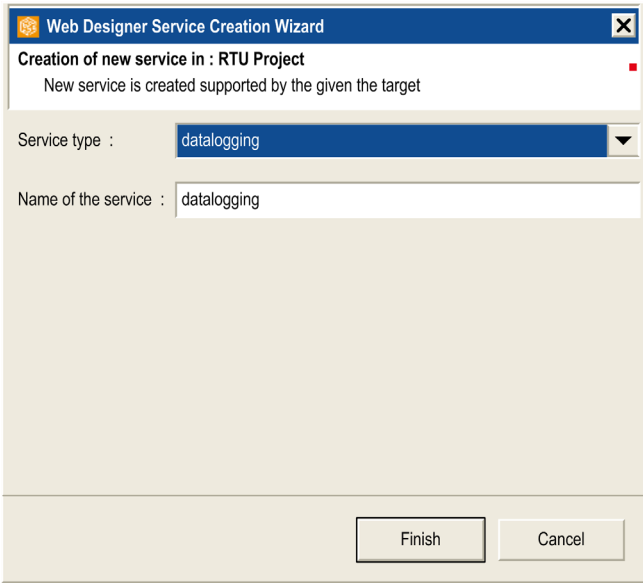
Step	Action
1	Click the name of your project in the browser.
2	<p>To add the new service:</p> <ul style="list-style-type: none"> ● click Project → New → Service or, ● right-click Services in the browser, then click New Service. <p>Result: the following window appears.</p> 
3	Select datalogging in the Service Type listbox.
4	Enter the service name or click Finish to keep the name by default.
5	The datalogging service has been created.

Datalogging Properties

Properties Tab

Initiate datalogging with a right-click on the service folder, then scroll to create a new service. Enter a name for the new datalogging service”

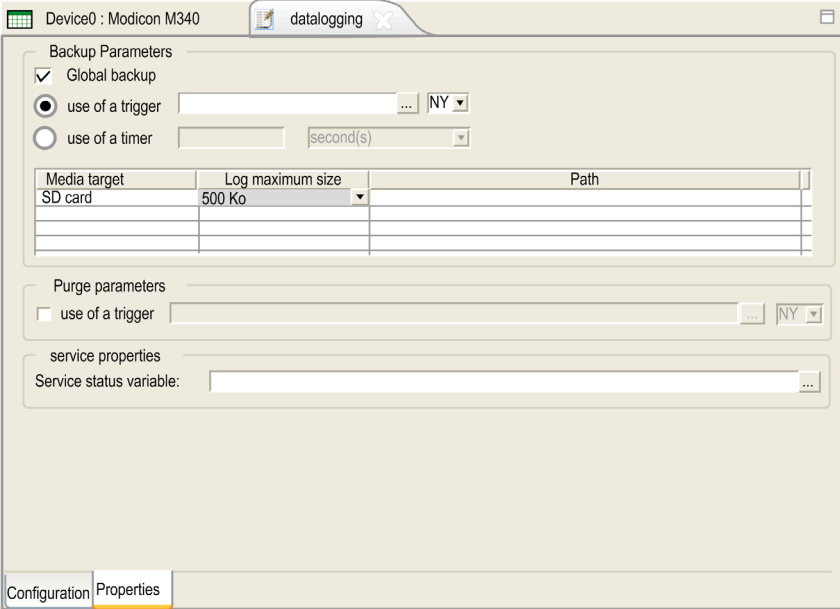

Backup Parameters:

Fields	Function
Global backup	When checked, the tables use the same event to trigger a backup. When not checked, each created table has its own event to trigger a back up. NOTE: When a Global backup check box is ticked, the fields use of a trigger and use of a timer become available.
use of a trigger	Provide the name of a variable to trigger variable logging on an event associated to this variable. NOTE: Select the type of your trigger in the drop down menu available on the left.
use of timer	Provide a periodic time base to trigger variable logging on an event.
Media target	SD card to store the information on the SD card of the module
Log maximum size	Specify the maximum size of memory allocated to the backup files. The maximum log file size is defined for each media via the drop down menu, but the value can be changed. For more information, refer to Datalogging Limitations.
Path	Provide the destination path for the media selected.

Purge Parameters:

Fields	Function
Use of a trigger	If checked, this event triggers a purge of the current backup files on all media currently in use. NOTE: Select the type of your trigger in the drop down.

Service Properties Parameters:

Fields	Function
Service status variable	Selects the variable with the associated event that is to be used as a trigger to check the status of the Datalogging service.

Datalogging Configuration

Configuration Tab

The datalogging service does not operate properly if the project is not synchronized with the latest build of Control Expert project before configuring datalogging service.

⚠ WARNING

UNEXPECTED DATA LOGGING OPERATION

Synchronize the project with the latest build of Control Expert project before configuring datalogging service.

Failure to follow these instructions can result in death, serious injury, or equipment damage.

This figure shows the **Configuration** tab for datalogging:

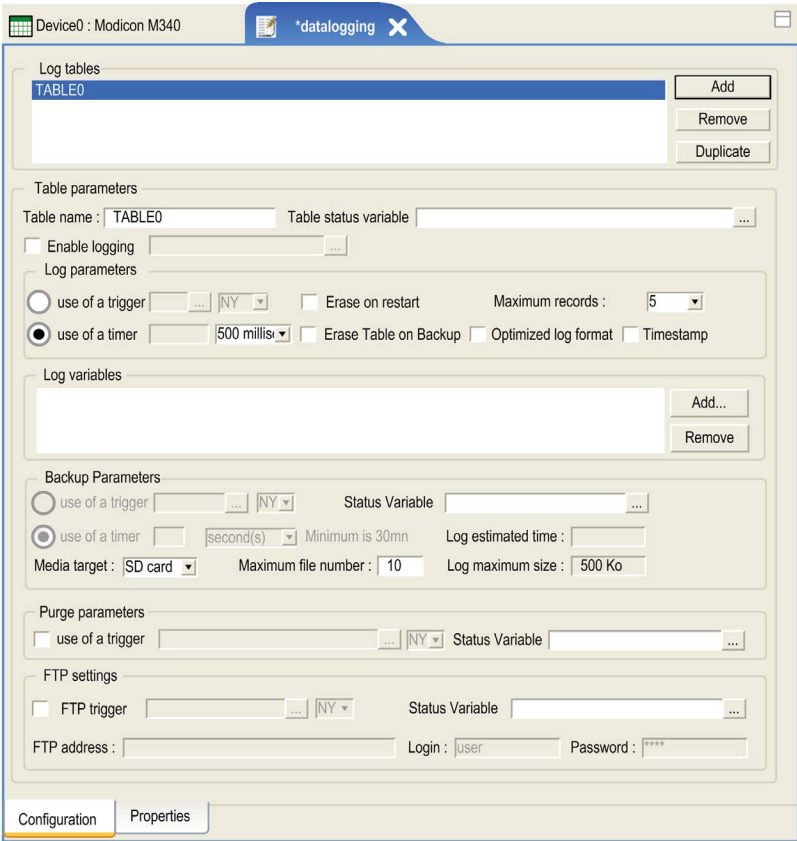

Log Tables

Log Tables Parameters:

Fields	Function
Log Tables	List of the current log tables stored in the module. It is possible to: <ul style="list-style-type: none"> ● Create a new log file using the Add button, ● Remove a log file using the Remove button, ● Duplicate a log file using the Duplicate button.

Table Parameters

Table Parameters:

Fields	Function
Table name	Name of the log file that contains the data you have configured.
Table status variable	Determine the status of the table.
Enable logging	By selecting this check box and defining an associated variable in the Enable logging variable, the table can only perform actions such as: log data, backup, purge or FTP when the associated variable is set to a value other than zero and when the trigger is activated. NOTE: Select the type of trigger in the drop down menu.

Log Parameters

Log Parameters:

Fields	Function
Use of a trigger / timer	To trigger logging of variables, configure an event in the Use of a trigger / timer variable. This event is either: <ul style="list-style-type: none"> ● a periodic event (use of a timer), in which case you need to set a time base ● an event associated with a variable (use of a trigger), in which case you need to provide the name of this variable (for example, plc.Device0.Pressure1). NOTE: Select the type of trigger in the drop down menu.
Erase on restart	Selecting this check box deletes the table log files on restart of the module.
Erase Table on Backup	Selecting this check box removes the previous logs in the table after backup, so the table restarts empty.
Timestamp	Selecting this box records in the log file Timestamp (hour and date) for each event. Note: Timestamps are mandatory if you want to use the log file for a Datalogging History.
Optimized log format	Selecting this box compacts the log file format (<i>see page 135</i>) of the <i>.csv</i> file. In this case, the variable name does not appear in each record.
Maximum record number	Configures the maximum of records that can be stored in a log file. If that number is reached, new records overwrite old records.

Log Variables

Log Variables Parameters:

Fields	Function
Log variables	<p>The variable name part lists the variables (PLC/devices or Calculation variables) that are stored in the log file.</p> <p>It is possible to:</p> <ul style="list-style-type: none"> ● Create a new log variable using the Add button ● Remove a log variable using the Remove button
<p>NOTE: The RTU module does not support variables that extract one bit from a word (for example a variable extracting %MW100.1 is not supported).</p>	

Backup Parameters

Backup Parameters:

Fields	Function
Use of a trigger / timer	<p>To trigger logging of variables, configure an event in the Use of a trigger / timer variable. This event is either:</p> <ul style="list-style-type: none"> ● a periodic event (use of a timer), in which case you need to set a time base ● an event associated with a variable (use of a trigger), in which case you need to provide the name of this variable (for example, calculation.calculation1.Pressure1). <p>The use of a trigger and use of a timer fields are grayed-out depending whether the Global backup check box from the datalogging properties windows (<i>see page 129</i>) is ticked or not.</p> <p>NOTE: Select the type of trigger in the drop-down menu.</p>
Media target	Use to define the media target to use.
Maximum file number	Defines the maximum number of CSV files to use for each table. By default it is set to 10. The maximum authorized value is 100. The last file is the .csv file, the previous is the .0 file, and the oldest is the .8 file.
Status variable	Determine the status of the Backup action. The status is set to 0 when the service starts, to 1 when the backup action begins, and to 2 when the backup action completes.
Log estimated time	Provides information on the time length of the log based on the maximum file number, the logging and backup period. It is only available when using a timer.
Log maximum size	Provides the maximum log size. This field can be changed via the backup parameters in the datalogging Properties Screen (<i>see page 129</i>).

Purge Parameters

Purge Parameters:

Fields	Function
Use of trigger	Specifies the event that triggers the purge.
Status Variable	Determine the status of the Purge action. The status is set to 0 when the service starts, to 1 when the purge action begins, and to 2 when the purge action completes.

FTP Settings

FTP Settings:

Fields	Function
FTP trigger	Specifies the event that triggers sending the selected table log files (CSV file) via FTP.
FTP address	The address of the remote FTP server.
Status Variable	Determine the status of the FTP action. The status is set to 0 when the service starts, to 1 when the FTP action begins, and to 2 when the FTP action completes.
Login and Password	Login parameters for the remote FTP server access.

Datalogging File Format

Summary

The file format is fixed and cannot be modified by the user. The file is encoded in pure ASCII format in a text file with a .csv extension. (Microsoft Excel can open .csv files.)

Examples

Example of a log file:

```
2003-10-01
02:44:55;plc.plc1.height;150;plc.plc1.length;200;plc.plc1.width;50;
2003-10-01
03:48:08;plc.plc1.height;140;plc.plc1.length;150;plc.plc1.width;30;
2003-10-01 04:55:10;
plc.plc1.height;220;plc.plc1.length;280;plc.plc1.width;80;2003-10-01
06:01:05; plc.plc1.height;170;plc.plc1.length;220;plc.plc1.width;60;
```

Example of an optimized log file:

```
Date;plc.plc1.height;plc.plc1.length;plc.plc1.width;
2003-10-01 02:44:55;150;200;50;2003-10-01 03:48:08;140;150;30;2003-10-
01 04:55:10;220;280;80;2003-10-01 06:01:05;170;220;60;
```

Recommendation on Datalogging Service

Size of the Log File

The following table shows you an estimation of the log file size in bytes depending on the number of variables logged and the number of logs:

Number of logs	Number of variables						
	1	2	5	10	20	50	100
1	65	110	245	470	920	2270	4520
2	130	220	490	940	1840	4540	9040
5	325	550	1225	2350	4600	11350	22600
10	650	1100	2450	4700	9200	22700	45200
20	1300	2200	4900	9400	18400	45400	90400
50	3250	5500	12250	23500	46000	113500	226000
100	6500	11000	24500	47000	92000	227000	452000

Chapter 9

How to Work with Email/SMS Service

Introduction

This chapter describes the Email/SMS Service and explains how to configure it.

What Is in This Chapter?

This chapter contains the following topics:

Topic	Page
About the Email Service / SMS Service	138
Create an Email Service	140
Email Properties	141
Email Configuration	143

About the Email Service / SMS Service

Presentation

The BMXNOR0200H module can automatically and dynamically send email or SMS to alert specified users to:

- alarm notifications
- maintenance reminders
- production reports
- plant status updates
- other process information

The email service enables you to create various email notifications (including recipient's names, email addresses, message subject, email body and attached files).

The body of an email can include fixed text messages, hyperlinks, file attachments, and real-time application values that are dynamically integrated into the email at the moment the email is sent by the module. The file can be attached to the email (for example, a datalogging file generated by the datalogging service).

SMS messages may also be sent to mobile phones if you are using a GSM modem or if the client email server has the capability. SMS is a dedicated configuration of the email service. Email or SMS are sent when predefined application or process event is triggered.

NOTE: The Email / SMS service is configured using Web Designer software.

NOTE: The SMS feature is supported only when a GSM or GPRS modem is configured. The SMS is sent only when the modem connection is not open.

Service Requirements

The email service provides only an SMTP client interface. The email service client connects to a local or remote SMTP server to distribute the mail to its recipients.

A local SMTP server has to be installed at the site where the BMXNOR0200H module is installed. A remote SMTP server may be available from your email provider.

The BMXNOR0200H module supports authentication functions in order to connect to the SMTP server of the provider. The module can communicate directly through SMS to a destination mobile phone without the installation of specific devices on the network.

Service Operation

The email service acts as an SMTP client. When the preconfigured event trigger occurs, the BMXNOR0200H module uses SMTP (over TCP port number 25) to send the email notification to the SMTP server. That server is connected to the plant network or to the Internet, thereby allowing the message to reach the destination recipients.

NOTE: Even though notifications are sent automatically after an event is triggered, there may be a significant delay before the recipient gets the message. A notification sent to a mobile phone is received only when the phone is on and within the coverage area. Therefore, this service should only be used for non-critical notifications, such as maintenance reminders or production reports.

Email and SMS Service Values

Value	Comment
0	The service is in stop mode.
1	The service is in run mode.
10	e-mail refused by SMTP server.
11	e-mail not sent, due to a connection interruption.
12	No more connections or queue saturated.

The highest values have the priority. The service value 12 has the priority but becomes 11 subsequently. The service value 11 disappears once the email has been sent correctly.

Create an Email Service

Procedure

This table describes the creation of an email service:

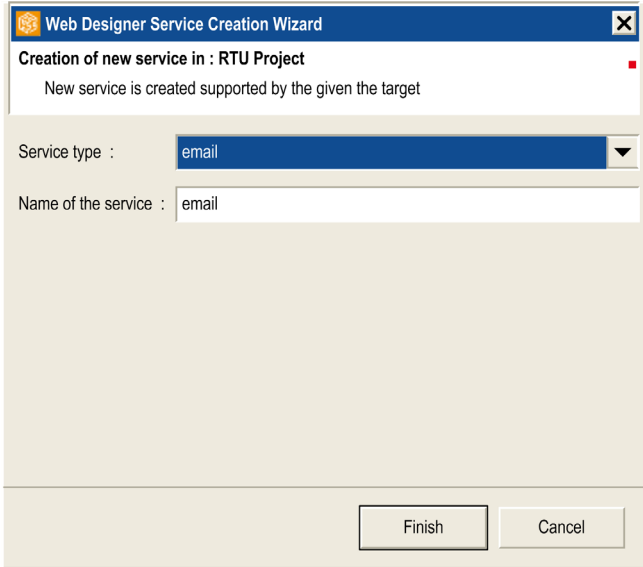
Step	Action
1	Click the name of your project in the browser.
2	<p>To add the new service you can:</p> <ul style="list-style-type: none"> ● Click Project → New → Service or, ● Right-click Services in the browser, then click New Service. <p>Result: the following window appears:</p> 
3	Select Email in the Service Type list box.
4	Enter a service name or click on Finish to keep the name by default.
5	The email service has been created.

Security

The email service supports SMTP server authentications. The SMTP server allows PLAIN or LOGIN authentication. Other authentication protocols are not supported. This optional login password is authenticated by the SMTP mail.

Email Properties

Properties Tab

This figure shows the available properties on the email tab:

The screenshot shows a software interface with a window titled "email" and a close button. The window contains several sections for configuring email properties:

- SMTP server**
 - SMTP server address:
 - SMTP server port:
 - SMTP server port:
 - Login:
 - Password:
- Sender**
 - Sender:
 - Reply address:
- Module**
 - Maximum size of send queue:
 - Time before retry to send (in seconds):
- Service**
 - Service status variable: ...

At the bottom left, there are two tabs: "E-mails" and "Properties", with "Properties" being the active tab.

This table describes the parameters on the **Properties** tab:

Field	Parameter	Description
SMTP server	SMTP server address	This is the address of the SMTP server.
	SMTP server port	This is the TCP port used by the SMTP server (generally port 25).
	Secure authentication	Select this box if authentication is required to access the SMTP server.
	Login	This is the login for SMTP server access.
	Password	This is the password to access the SMTP server.
	Sender	This is the email address of the message sender.
	Reply Address	This is the email address to which a reply will be sent when you click Reply .
Module	Maximum size of send queue	This is the maximum number of emails that can be stored in the buffer's memory before being sent.
	Time before retry to send (in seconds)	This is the delay before emails stored in the buffer memory are re-sent after the detection of an undelivered email.
Service	Service status variable	Use this parameter to determine the status of the email service.

When the maximum number of mails is reached (100), no further messages are stored.

Limitation

The number of messages you can configure in the project is restricted to 100.

NOTE: The SMTP server allows PLAIN or LOGIN authentication. Other authentication protocols are not supported.

Email Configuration

Configuration Tab

Email configuration screen:

The screenshot shows the 'email' configuration tab in a software interface. At the top, there are tabs for 'Device0 : Premium', 'Device0 : Modicon M340', '*datalogging', and 'email'. The 'email' tab is active. Below the tabs, there is a 'SendSMS' checkbox. The main area is titled 'E-mail description' and contains several input fields: 'Identifier', 'Destination', 'Contents' (a large text area), 'Trigger', 'Subject', and 'Type' (a dropdown menu). Below these fields are 'Source' and 'Path' fields. At the bottom, there is a table with columns for 'Identifier', 'Destination', 'Subject', 'Trigger', 'Type', and 'Remove'. The table is currently empty. At the very bottom, there are two tabs: 'E-mails' and 'Properties'.

Identifier	Destination	Subject	Trigger	Type	Remove

This table describes the parameters on the **Configuration** tab:

Parameter	Description
SendSMS	Check this box to indicate that the service can be configured to send an SMS message.
Identifier*	The email address of the message sender
Trigger*	The event that triggers the email
Type	NY: (notify): triggered by a bit status change or word value change
	RE: (rising edge): triggered by a bit's rising edge or an increasing word value
	FE: (falling edge): triggered by a bit's falling edge or a decreasing word value
	BQ: (bad quality): triggered when the trigger status is of poor quality
Destination*	Email address(es) of the receiver(s) of the message
Subject	A brief summary of the message's contents
Contents	Type the content of the message in this area.
Source	Select the source from which the attached file comes.
Path	Specify the path of the file.
*These parameters are required to record and save an email.	

Dynamic Data

The email service enables you to include dynamic data in the body of the email. You can include dynamic data manually or automatically:

- **manual:** Place brackets before and after the variable name. For instance, to learn the value of the value1 variable created in the device service, type `write {plc.plc1.value1}`. (You can include comments before and after the brackets.)
- **automatic:** Double-click the location to which you want to include dynamic data. When the lookup table appears, you can select the variables that will appear in the email.

Configuring European SMS Format

Before sending an SMS, you must configure the parameters from the Modem GSM window, as shown below:

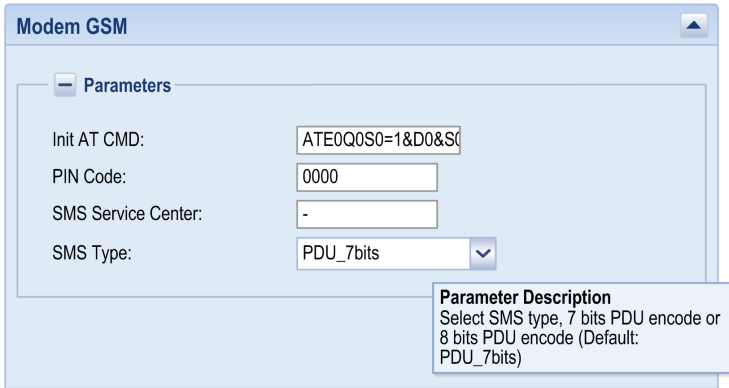

The screenshot shows a window titled "Modem GSM" with a "Parameters" section. The parameters are:

Init AT CMD:	ATE0Q0S0=1&D0&S0
PIN Code:	0000
SMS Service Center:	-
SMS Type:	PDU_7bits

Parameter Description
Select SMS type, 7 bits PDU encode or 8 bits PDU encode (Default: PDU_7bits)

The Modem GSM parameter settings available:

Parameter	Value Scope	Default Value	Description
Init AT CMD	–	ATE0Q0S=1&D0&S0&C0	A custom AT command is specified by user. This command initializes the modem.
PIN Code	4-8 digits	0000	PIN code for the SIM card
SMS Service Center	phone number whose length depends on service supplier	–	The number of the SMS service center.
SMS Type NOTE: This parameter is supported from firmware V1.6.	PDU_7bits/ PDU_8bits	PDU_7bits	Specifies how the SMS message will be encoded and sent: <ul style="list-style-type: none"> ● If encoded as 7bits, the message will be sent as a text message. ● If encoded as 8bits, the message will be sent as a data message. NOTE: This parameter is supported on most mobile telephones.

Chapter 10

How to Work with Embedded Web Pages

Introduction

This chapter discusses the embedded web pages that are hosted by the BMXNOR0200H Web serve.

The built-in HTTP server (Hyper Text Transfer Protocol) allows remote and local access to the embedded Web pages through standard browsers such as Internet Explorer or Firefox Navigator.

What Is in This Chapter?

This chapter contains the following sections:

Section	Topic	Page
10.1	Embedded Web Pages	148
10.2	Home Web Page	149
10.3	Setup Web Pages	150
10.4	Diagnostics Web Pages	156
10.5	Monitoring Web Pages	168

Section 10.1

Embedded Web Pages

Introduction to Embedded Web Pages

Overview

The BMXNOR0200H module has a built-in Web server that provides various Web pages offering setup, diagnostic and monitoring features.

Browser and Java version requirements:

Browser and Java	Requirement
Internet Explorer	≥ V6
Mozilla Firefox	≥ V40
Java	≥ V1.8.0

Section 10.2

Home Web Page

Home Page

Introduction

Access the BMXNOR0200H module **Home** page by entering the IP address or URL of the module in a web browser. (No password is required to display the **Home** page.)

Home Page



From the **Home** page, you can access the following pages:

- Monitoring (*see page 169*)
- Diagnostics (*see page 157*)
- Setup (*see page 151*)

Section 10.3

Setup Web Pages

What Is in This Section?

This section contains the following topics:

Topic	Page
Module Setup	151
Security	153
FTP Security Page	155

Module Setup

Setup Overview

Setup Web pages allow the configuration of the following functions:

- Serial port setup
- Modem setup
- RTU protocol setup
- Security password setup
- Export/import setup files

Setup Page

From the BMXNOR0200H module **Home** page, click the **Setup** link to display this page:

Setup

Monitoring
Control
Diagnostics
Maintenance
Setup

- Communication
 - Channel Parameters
 - Modem
 - Parameters
 - Serial Port
 - Parameters
 - PPPoE
 - Parameters
- Channel
 - IEC-104 Server
 - Parameters
 - Session 0
 - Parameters
 - Sector 0
 - Parameters
 - Data Mapping
 - Events

Reset Communication

Export/Import files

Security

FTP



Copyright © 2010, Schneider Automation SAS. All Rights Reserved.

NOTE:

The user name and password must be typed when the first time log on setup page:

- user name: USER
- password: USER

Links

You can access these pages directly from the **Setup** page:

- Export/Import files (*see page 212*)
- Security (*see page 153*)
- FTP (*see page 155*)

NOTE: The Setup menu is explained in the Configuration with the Web Site (*see page 195*) topic.

Security

Introduction

Access this page with the **Security** link on the Setup page (*see page 151*). Use the Security page to:

- modify the user name and the password for accessing the index page
- modify the password for writing variables in the data editor (You can read the data editor values without a password.)

The maximum size of the user name or passwords is 15 characters (non-extended ASCII).

Security Page

The security page appears:

HTTP access rights

Username :	<input type="text"/>
New password :	<input type="text"/>
Confirm password :	<input type="text"/>

Change Password

Data Editor Write Password

Data Editor Write Password:	<input type="text"/>
New Write password :	<input type="text"/>
Confirm write password :	<input type="text"/>

Change Write Password

Copyright © 1998-2010, Schneider Automation SAS, All Rights Reserved.

Modify the HTTP access rights:

Step	Action
1	Enter the new username. (The default value of this field is: USER.)
2	Enter the new password. (The default value of this field is: USER.)
3	Confirm the new password by entering it again.
4	Confirm the modification using the Change Password button.

Modify the Data Editor Write Password:

Step	Action
1	Enter the current password (case sensitive). (The default value of this field is: USER.)
2	Enter the new password (default is USER).
3	Confirm the new password by entering it again.
4	Confirm the modification with the Change Write Password button.

FTP Security Page

Introduction

You can modify the username and password for FTP access rights on this page.

NOTE: You can download Web pages to the C type memory card over FTP.

FTP Page

The Setup page (*see page 151*) has a link to the FTP password page:

FTP access rights

Username (1-40 chars):

New password (8-40 chars):

Copyright © 2000-2008, Schneider Automation SAS. All rights reserved.

Follow these steps to modify the FTP username and password:

Step	Action	Comment
1	Enter the Username .	The default is USER .
2	Enter the New password .	The default is USER .
3	Confirm the New password .	Enter the new password again.
4	Confirm the modification using the Change Password button.	

Section 10.4

Diagnostics Web Pages

What Is in This Section?

This section contains the following topics:

Topic	Page
Diagnostics	157
PLC Rack Viewer Page	158
Messaging	160
NTP Diagnostics	161
Clock Diagnostics	163
Statistics	164
Upload MIB File	166
Properties	167

Diagnostics

Diagnostics Page

From the BMXNOR0200H module **Home** page, click the **Diagnostics** link to display this page:

Links

From the BMXNOR0200H Diagnostics page, you can access the following pages:

- **RTU Protocol:** See the description for the RTU Connection and Clock Diagnostics ([see page 163](#)).
- **Rack viewer:** See the description for the Rack Viewer page ([see page 158](#)).
- **Ethernet:** You can diagnose the status of Ethernet services through these links:
 - Messaging ([see page 160](#))
 - Statistics ([see page 164](#))
 - NTP ([see page 161](#))
 - Upload MIB file ([see page 166](#))
- **Modem:** See the description for the PPP / Modem and PPPoE Statistics Page ([see page 165](#)).
- **Clock:** See the description for the RTU Connection and Clock Diagnostics ([see page 163](#)).
- **Memory:** See the description for the System Memory Statistics Page ([see page 165](#)).
- **Properties:** See the description for the Properties Diagnostics ([see page 167](#)).

PLC Rack Viewer Page

Introduction

The **Rack Viewer** page allows you to carry out diagnostics on the modules in the local rack configuration that includes the BMXNOR0200H module.

Click the module in the configuration to obtain a set of diagnostic information on this module:

- LED status display
- module type and the version of the module and its rack position
- information that is specific to module functions

Rack Viewer Page

Follow these steps to access the rack display page from the **Home** page:

Step	Action
1	Click the Diagnostics link.
2	Click the Rack Viewer link.

The rack display page appears:

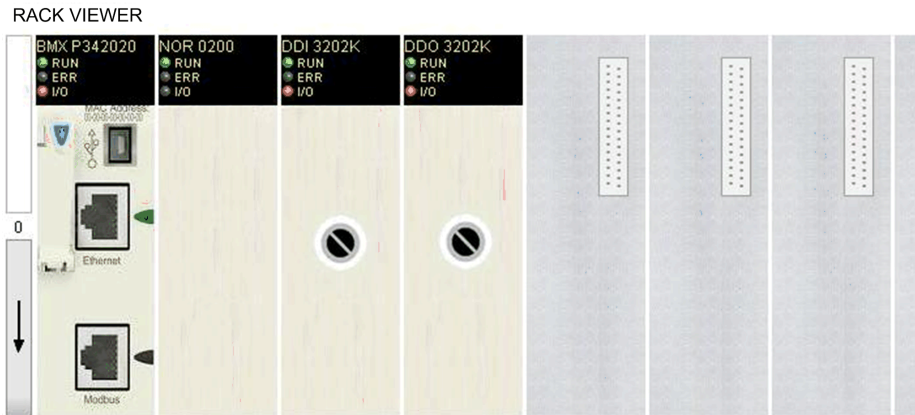

Leds:	Rack:	0	Product Range:	M340
● RUN	Slot:	1	Trade Type:	Communication
● ERR	Module State:	Ok	Product Type:	Ethernet
Reference Present:		BMX NOR 0200	Reference Configured: BMX NOR 0200	
Version:		1.5		

Parameters

IP Address: **139.160.64.108** IP Address: **255.255.252.0** Gateway:**139.160.64.108**
Name: MAC Address: **0.80.f4.1.fd.ff**

Services	Status	Counter
Port 502:	Yes	Generic faults: No Refused port 502 connections: 0
IO Scanner:	No	Ethernet interface disabled: No Received messages (/sec): 25
Global data:	No	Duplicate IP Address: No Filter messages (/sec): 10
Emails:	No	Configuration mismatch: No Dropped messages (/sec): 0
Server FDF:	No	Obtaining IP address: No Max received messages (/sec): 2893
		Self-test fault: No Max Filter messages (/sec): 10112
		Application faults: No Max dropped messages (/sec): 46132
		Nb of Multicast (/sec): 9
		Nb of Broadcast (/sec): 2893



Messaging

Diagnostics Page

Click this link to see the current information on the open TCP connection on port 502.

MESSAGING DIAGNOSTIC

Number of Messages sent: 38 | Number of Messages received: 183

Conn.#	Remote address	Remote Port	Local Port	Mess. Sent	Mess. Received	Error Sent
1	192.160.10.20	1920	502	20	12	0
2	139.160.235.90	2020	502	0	30	02
3	192.160.10.21	502	3000	3	60	0
4	139.160.234.20	1050	502	15	42	0
5	139.160.234.18	5120	502	0	39	1

The number of sent/received messages on the port can be found at the top of this page. A table provides, for each connection (numbered from 1 to 64):

- Remote address
remote IP Address
- Remote Port
remote TCP port
- Local Port
local TCP port
- Mess. Sent
number of messages sent from this connection
- Mess. Received
number of messages received from this connection
- Error Sent
error number on this connection

NTP Diagnostics

NTP Diagnostic Page

Use the **NTP** link on the **Diagnostics** page to access NTP information:

NTP Status		
Status	Operational	

NTP Server Status		
Linked to NTP server	<input type="checkbox"/>	Server address <input type="text" value="139.160.65.133"/>
Server	<input type="text" value="Primary"/>	

NTP Request Statistic		
NTP requests	<input type="text" value="2"/>	NTP errors <input type="text" value="0"/>
NTP responses	<input type="text" value="2"/>	Last error <input type="text" value="0"/>

NTP Date and Time		
Date	<input type="text" value="12 Apr 2010"/>	Time <input type="text" value="15:32:15"/>
DST status	<input type="text" value="ON"/>	
Time zone	<input type="text" value="(GMT+01:00)Romance Standard Time[Amsterdam CopenHagen Madrid Paris Vilnius]"/>	

Links

This page displays the information related to the NTP service:

- **NTP Status:** The service is correctly configured.
- **NTP Server Status:** This field indicates if the NTP client is connected to the NTP server and if the server is primary or redundant.
- **NTP requests:** This is the total number of client requests sent to the NTP server.
- **NTP responses:** This is the total number of server responses sent from the NTP server.
- **NTP errors:** This is the total number of NTP request that did not get a response.
- **Last error:** This is the last detected error code received by the NTP client.
- **Date:** This is the date format (D/M/Y).
- **Time:** This is the time.
- **Time zone:** This is the time zone (according to UTC).
- **DST status:** This is the daylight saving time.

Error Codes

Code	Description
0	The component is OK and is executing.
1	There is either too much traffic or a server overload.
3	Incorrect configuration parameters were detected.
4	A disabled component was detected.
9	An incorrect IP address was detected.
14	The Time zone file is missing.
15	There was a detected syntax error in the "custom rules" file.

Clock Diagnostics

RTU Clock

Use the **Diagnostics** page to access the RTU clock information:

CLOCK DIAGNOSTICS

Clock Status	
Synchronized	No

Current Date and Time			
Date	11/11/2011	Time	06:56:28

Latest Time Synchronization					
Date	11/11/2011	Time	06:12:51	Time Source	CPU Module

Example of RTU clock:

Type	Name	Value/scope	Description
Clock Status	Synchronized	yes/no	10.0.0.1
Current Data and Time	Date	4/12/2010	RTU date
	Time	18:06:59	RTU time
Latest Time Synchronization	Date	4/12/2010	timestamp of synchronization
	Time	18:06:59	timestamp of synchronization
	Time Source	Controlling Station/CPU Module/NTP server	time source of synchronization

Time Source

This page displays the information related to the clock status:

- **None:** If no RTU protocol is configured, the BMXNOR0200H clock is free running, its time is from 1970/1/1.
- **CPU Module:** If the RTU protocol is configured, the BMXNOR0200H can get the initial time from the CPU when the RTU protocol starts/restarts.
- **Controlling Station:** If SCADA or master synchronizes time with the BMXNOR0200H, its time source is the Controlling Station.
- **NTP server:** If the NTP client is enabled and connected with the NTP server, its time source is the NTP server when it synchronizes the BMXNOR0200H module clock.

Statistics

Ethernet Statistics Page

The statistic page displays Ethernet informations from the module such as state, transmit statistics, collision, receptions...

Use the **Statistics** link on the **Diagnostics** page to access the Ethernet statistics:

Status:	Running Link	Host Name:	So-etg1000.aut.schnei
Reference:	BMX NOR 0200	MAC Address:	00 80 f4 01 fd ff
Rack:	0	IP Address:	139.160.64.108
Slot:	1	Subnet Mask:	255.255.252.0
Transmit Speed:	100 MB	Gateway Address:	139.160.64.1

Transmit Statistics		Receive Statistics		Functioning Errors	
Transmits	72634	Receives	98082545	Missed Packets	120830
Transmit Retries	0	Fighting Errors	0	Collision Errors	0
Lost Carrier	0	Overflow Errors	0	Transmit Timeouts	0
Late Collision	0	CRC Errors	0	Memory Errors	0
Transmit Buffer Errors	0	Receive Buffer Errors	14	Net Interface Restarts	0
Silo Underflow	0				

Reset counters

RTU Connection Page

Use the **Diagnostics** page to access the RTU protocol statistics:

RTU PROTOCOL DIAGNOSTICS

RTU Connections							
	Channel	Protocol	State	Remote IP	Remote Port	Local Port	Error Code
1	19	IEC104 Server	CONNECTING	10.177.90.244	0	3c2a	0x00003C29
2	21	IEC104 Server	CONNECTED	10.177.75.242	0	5a32	0x00000000
3	23	IEC104 Server	CONNECTING	10.177.75.61	0	3c2a	0x00003C29
4	25	IEC104 Server	CONNECTING	10.177.75.4	0	3c2a	0x00003C29
5	27	IEC104 Server	CONNECTING	10.177.75.5	0	3c2a	0x00003C29
6	29	IEC104 Server	CONNECTING	10.177.75.6	0	3c2a	0x00003C29
7	31	IEC104 Server	CONNECTING	10.177.75.7	0	3c2a	0x00003C29

PPP / Modem and PPPoE Statistics Page

Use the **Statistics** link on the **Diagnostics** page to access the PPP / modem and PPPoE statistics:

Status	
Modem	PSTN
Mode	CLIENT
Connection	INACTIVE
Phone number	8767
InitAT Cmd	NA

PPPoE Status	
Mode	CLIENT
Connection	INACTIVE
Local PPPoE Address	NA

IP address	
Local PPP address	NA
Remote PPP address	NA

System Memory Statistics Page

Use the **Statistics** link on the **Diagnostics** page to access the system memory statistics:

CPU Module	
Number of %M	32634
Number of %MW	32464

Memory	
Free memory size	50486600

Upload MIB File

File Download Dialog

When you select **Upload MIB File**, the **File Download** dialog box appears. You are asked if you want to save the MIB file or open it:

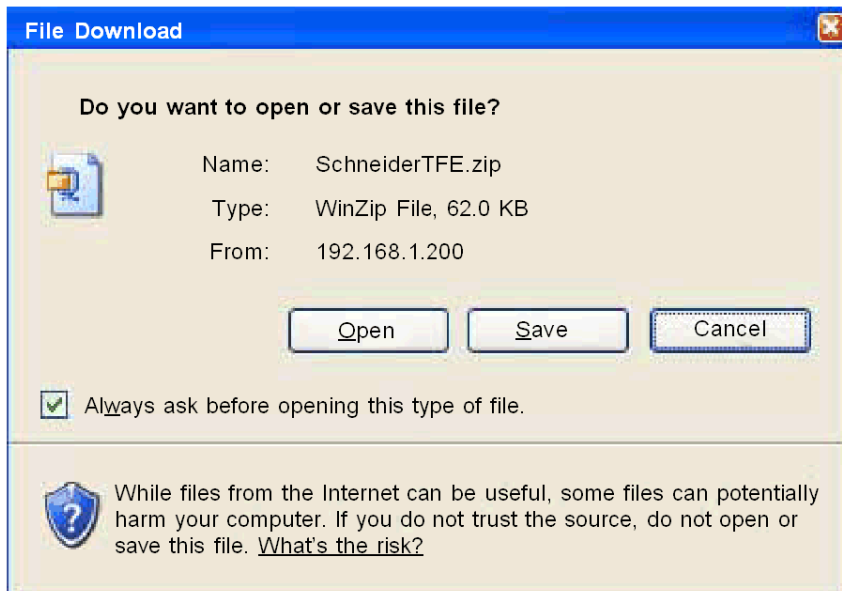

Properties

Properties Page

Use the **Properties** link on the **Diagnostics** page to access the module properties:

Exec Version:	1.50
Kernel Version:	1.14
Web Server Version	2.1.0
Web Pages Version	1.00.07
Physical Media:	10/100BASE-T

Section 10.5

Monitoring Web Pages

What Is in This Section?

This section contains the following topics:

Topic	Page
Monitoring	169
Data Editor	170

Monitoring

Monitoring Page

From the BMXNOR0200H module home page, click the **Monitoring** link to display this page:



Links

You can access these pages directly from the **Monitoring** page:

- **Data Editor:** Use the Data Editor to access the CPU data.
- **Data Editor Lite:** This smaller version of the Data Editor loads faster, and can access most of the CPU data.

Data Editor

Data Editor Page

Use the Data Editor to create variables animation tables. These tables are animated to display the variable values.

Variables that can be written are accessible only by trained personnel (password protect).

⚠ WARNING

UNINTENDED OPERATION

Apply password protection to limit access to the Data Editor.

Failure to follow these instructions can result in death, serious injury, or equipment damage.

From the **Monitoring** tab, select the **Data Editor** link to view this screen:

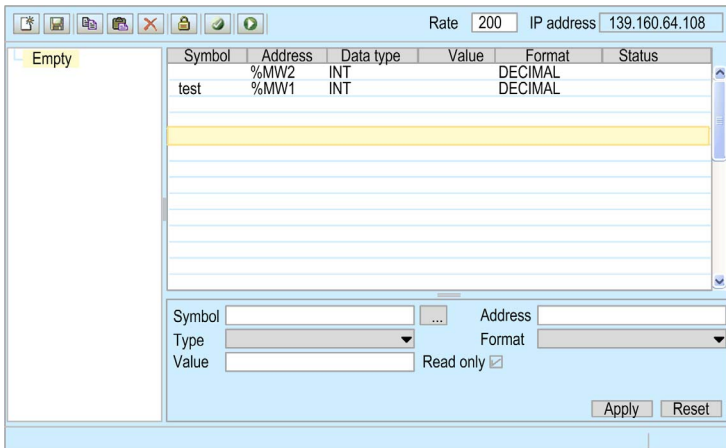

The data editor is dynamic. Tables can be created on the Web Designer and transferred to the module, or they can be directly created in the website by selecting variables from the namespace or user manual inputs.

Data Editor Lite

The Data Editor Lite is similar to the Data Editor. The Lite version has restrictions related to available data types and is dedicated to modem connection (slow Ethernet connection). It allows a faster download than with the data editor. From the **Monitoring** tab, select the **Data Editor Lite** link to view the screen.

Part V

Configuring the Module

Introduction

This part describes the configuration of the BMXNOR0200H module.

What Is in This Part?

This part contains the following chapters:

Chapter	Chapter Name	Page
11	Configuring the Module	173
12	Configuration and Debug with Control Expert	175
13	Configuration with the Setup Web Pages	189
14	Web Designer Configuration	321

Chapter 11

Configuring the Module

Configuration Methodology

Overview

Follow these main steps to configure the RTU module:

Step	Action	Comment
1	Set up the PLC hardware configuration through Control Expert.	Configure the RTU module in the PLC rack. Set the Ethernet parameters and assign a valid IP address (<i>see page 195</i>).
2	Log in to the module website and set the module and protocol parameters and the data object mapping.	Any configuration parameter changes require a module reset.
3	Export the module website and protocol parameter configuration to a local storage media (*.XML file) (<i>see page 212</i>)	This creates a backup of the configuration parameters.
4	Export the data object mapping to a local storage media.	Export is done as a *.XSY file, ready for Control Expert import. (<i>see page 212</i>)
5	Import the *.XSY file into the Control Expert application.	This allows you to import the RTU data such as unlocated variables as symbols for PLC programming.
6	Complete the PLC application program.	Consider your application requirements, scan time, etc.
7	Download the application to the PLC.	The RTU functionalities are ready to use.
8	RTU module firmware: <ul style="list-style-type: none">• < V1.7: Click 'Reset Communication' in the webpage.• ≥ V1.7: RTU protocol is automatically reset, event buffer is cleared.	The new configuration is effective.

NOTE: Repeat these steps to refresh the variable definitions in Control Expert when the data object mapping list is modified.

NOTE: This module does not have an internal RAM backup function. The RAM is erased when the power is switched off.

Optional Configuration

Web Designer configuration software is used to setup the X80 device variable list and additional functions, such as datalogging, email services, and data table lists.

Chapter 12

Configuration and Debug with Control Expert

Introduction

The configuration or debugging the configuration of the BMXNOR0200H module relies on the hardware module configuration through Control Expert software.

What Is in This Chapter?

This chapter contains the following sections:

Section	Topic	Page
12.1	Configuration with Control Expert	176
12.2	Debugging with Control Expert	182

Section 12.1

Configuration with Control Expert

What Is in This Section?

This section contains the following topics:

Topic	Page
Configuring with Control Expert	177
Configuration Screen	180

Configuring with Control Expert

Module Reference

Find the module reference in Control Expert:

Step	Action
1	Open the PLC Bus view.
2	Right-click on an empty slot and select New Device .
3	In the Part Number column, expand Communication to see the available modules, including the BMXNOR0200H.

NOTE: In a Modicon M340 system the total number of communication modules, such as BMX NOE 01•0 or BMXNOR0200H modules, cannot exceed two. The maximum Ethernet port for M340 system is 3 including the port on PLC. Therefore, a maximum of two BMXNOR0200H modules can be inserted in a M340 system.

NOTE: For Modicon M580 system module limitations, refer to topic *System Throughput Considerations* (see *Modicon M580 Standalone, System Planning Guide for, Frequently Used Architectures*).

New Device

The module is referenced as a BMX NOR 0200 in Control Expert. It is available under **Communication** in the **New Device** menu:

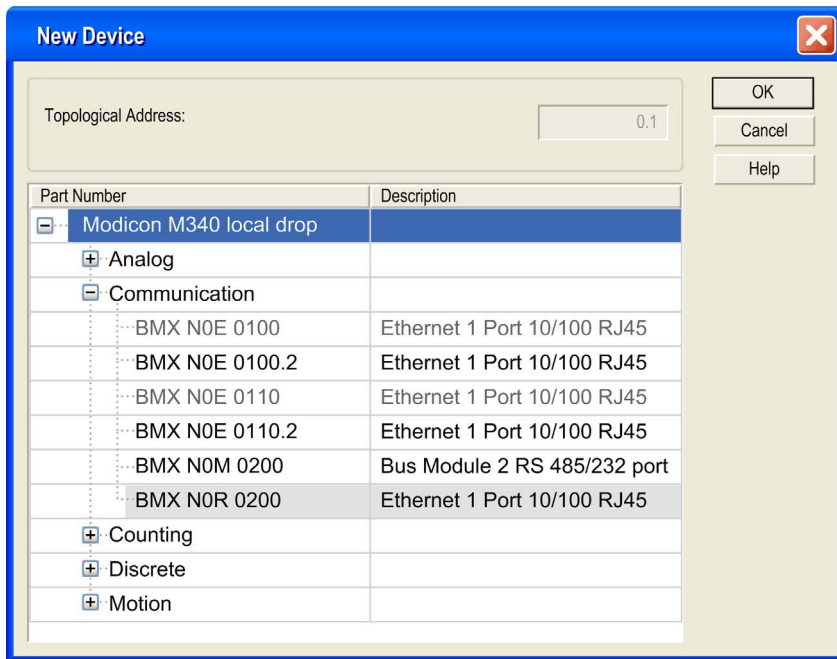

Only Ethernet port (channel 0) is configurable in Control Expert. Serial port is configured through the Web.

The Control Expert description for this module is "Ethernet TCP/IP, RTU module":

Ethernet TCP/IP, RTU module

SPECIFICATIONS

Network type	RTU on TCT/IP, serial and modem connections		
Structure			
Physical interface	100baseT(RJ45) - Serial port configured by Website		
Data rate	10/100 Mbps		
Services			
Message handling	Modbus TCP and RTU protocols		
Web server	Integrated web server : diagnostic		

VISUAL INDICATORS

LED	On	Flashing	Off
RUN (green)	Module is operating		
ERR (red)	Module error		Normal state, no internal error

Configuration Screen

Module Configuration Screen

Use this screen to declare the communication channel (0) and to configure the necessary parameters for the Ethernet port on the BMXNOR0200H module:

The configuration screen is divided into several zones:

- **Model Family:** Select the model family for configuration.
- **Module Address:** When the selected network is associated with a module, the rack, module, and channel appears in this zone.
- **Module Utilities:** Select the utilities used by the module.
- **Module IP Address:** This field displays the module IP address.
- service tabs: To configure a particular service, select the appropriate tab.
 - **Security tab** (*see Modicon Controllers Platform, Cyber Security, Reference Manual*): Configure a system that is less susceptible to cyber attacks. This feature is available with firmware V1.7 or later.
 - **IP Configuration tab** (*see page 53*): Declare the communication channel and configure the necessary parameters for an Ethernet port
 - **Messaging tab:** (*see page 59*) Access on the Connection configuration area and the access control area

Project Settings

Check the **Data dictionary** option when you program the PLC application. Otherwise unlocated variables may not be mapped to RTU data points. (Find this check box at: **Tools** → **Project Settings** → **General** → **PLC embedded data**.) However, a compiled application consumes more memory when the **Data dictionary** is included. Be aware of this memory constraint when applying unlocated variables in RTU solutions:

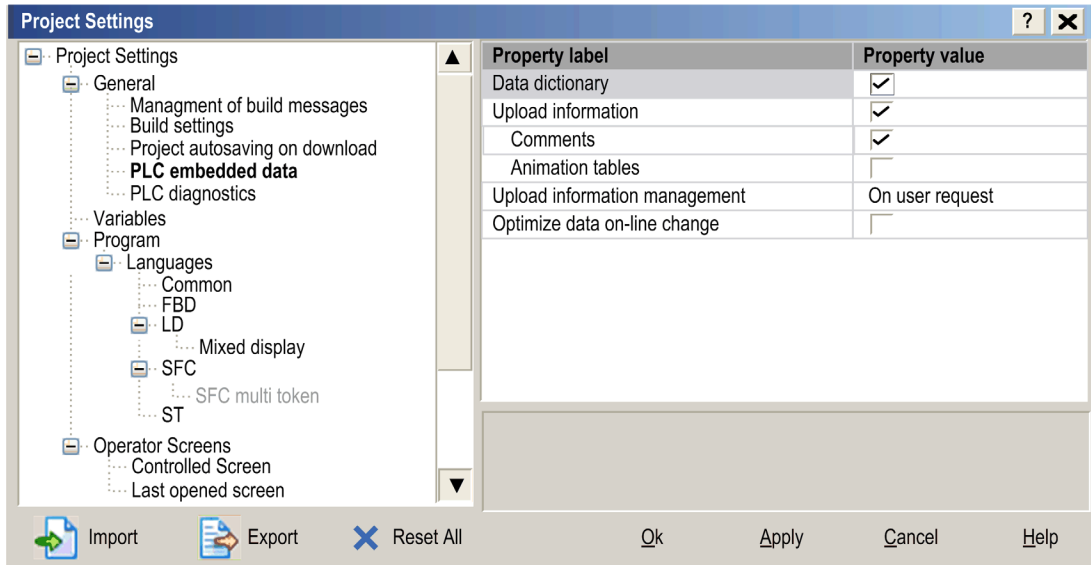

Section 12.2

Debugging with Control Expert

Overview

This section describes procedures for debugging the configuration of an RTU modules with Control Expert.

What Is in This Section?

This section contains the following topics:

Topic	Page
Module Debugging Screen	183
General Debugging Parameters	185
Debugging Parameters for TCP/IP Utilities	187

Module Debugging Screen

Screen

This four-zone Control Expert **Debug** tab provides options to debug an Ethernet port.

NOR screen:

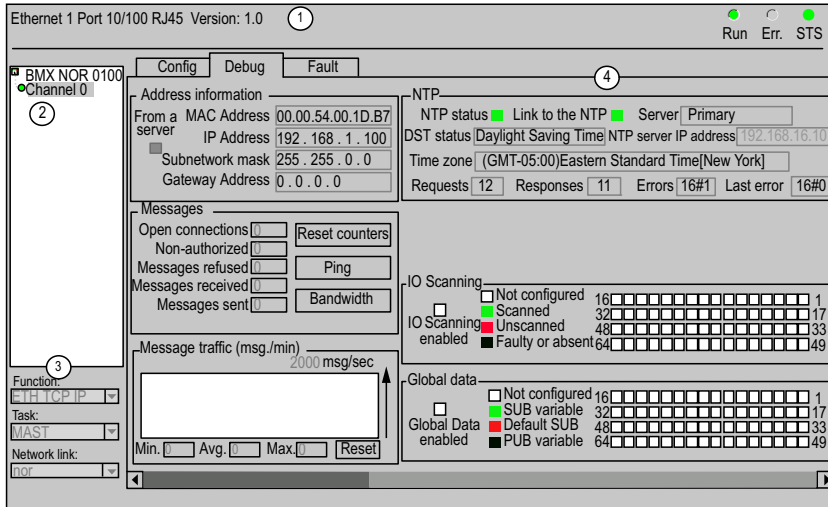

This table describes the zones in the configuration screen:

Zone	Function		
1: Module	module description zone (For details refer to LED Indicators (<i>see page 29</i>)).	Run	<ul style="list-style-type: none"> ● on: module is operating ● off: PLC not configured
		Err.	<ul style="list-style-type: none"> ● on: configuration or system error has been detected ● off: operation is normal
		STS	<ul style="list-style-type: none"> ● on: communication is OK ● flashing: communication error detected
2: Channel	channel selection zone		
3: Parameters	general parameters zone		

Zone	Function	
4: Debug tab	Address information	<ul style="list-style-type: none"> ● displays TCP/IP utility configuration ● tests communication of the TCP/IP profile
	Messages	displays the number of open connections and the number of messages that are unauthorized, refused, received, and sent.
	Message traffic	displays the number of messages processed by the module per minute
	NTP	displays the status of the NTP server

General Debugging Parameters

Introduction

The general debugging parameters on the module debugging screen (*see page 183*) are grouped into two windows:

- the **Message traffic** window
- the **Messages** window

Message Traffic

The **Message traffic** window looks like this:

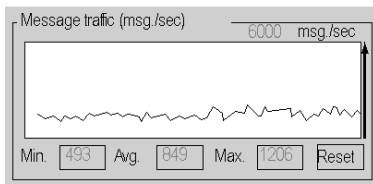

It graphically shows the number of Ethernet packets per second handled by the module (sent and received).

The **Reset** button resets the **Min.**, **Av.**, and **Max** counters to 0.

Messages

The **Messages** window looks like this:

The screenshot shows a window titled 'Messages'. It contains five rows of counters, each with a text label and a numeric input field set to '0': 'Open connections', 'Non-authorized', 'Messages refused', 'Messages received', and 'Messages sent'. To the right of these counters are three buttons: 'Reset counters', 'Ping', and 'Bandwidth'.

This window reports the number of:



- open TCP/IP connections (the combined number of server, client, and Transparent Device Access connections that are open)
- non-authorized TCP/IP connections
- refused TCP/IP messages
- received TCP/IP messages
- sent TCP/IP messages

This window includes three buttons:

- **Reset counters:** Press this button to reset the counters to 0.
- **Ping** (see below)
- **Bandwidth** (see below)

Ping

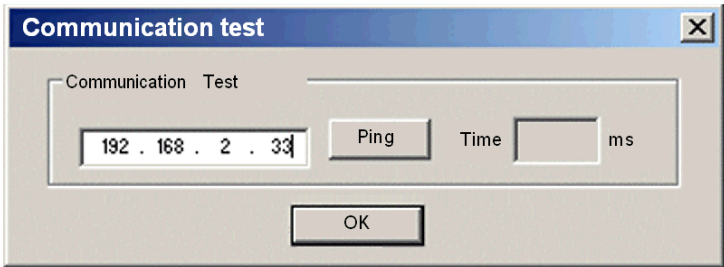
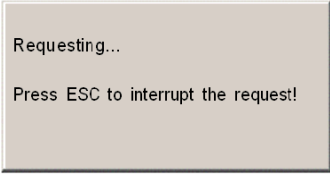
You can test the routing between your module and another device through a PING request:

Step	Action	Comment
1	Enter the IP address of the device for which you want to test communications and press Ping.	
2	Wait for the request to be processed	This window appears: 
3	The COMMUNICATION window informs you that the exchange was successful.	The COMMUNICATION window: 
4	Press OK .	With the successful PING request, a value appears in the ms field.

Debugging Parameters for TCP/IP Utilities

Address Information

The debugging parameters for TCP/IP utilities on the module debugging screen (*see page 183*) are grouped together in the **Address information** window:

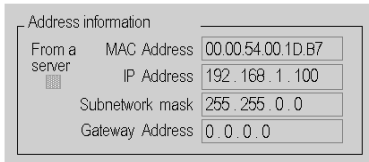

The screenshot shows a window titled "Address information" with a "From a server" checkbox. Below the checkbox are four input fields for network configuration parameters.

Field	Value
MAC Address	00.00.54.00.1D.B7
IP Address	192.168.1.100
Subnetwork mask	255.255.0.0
Gateway Address	0.0.0.0

This window displays the configuration of:

- MAC Address
- IP Address
- Subnetwork mask
- Gateway Address

Chapter 13

Configuration with the Setup Web Pages

Overview

This chapter describes how to configure the following module parameters:

- serial port and Ethernet port parameters configuration
- modem parameters configuration
- IEC 61508-5-101/104/ DNP3 protocols parameters configuration

What Is in This Chapter?

This chapter contains the following sections:

Section	Topic	Page
13.1	Web Site Configuration Common	190
13.2	Web Site Configuration IEC	219
13.3	Web Site Configuration DNP3	273

Section 13.1

Web Site Configuration Common

What Is in This Section?

This section contains the following topics:

Topic	Page
Parameter Input Interface in Setup Web Pages	191
Channel Configuration	195
Serial Port Configuration	200
Ethernet Port Configuration	208
RTU Protocol Parameters	209
Time Zone Configuration	210
Module and Protocols Configuration File	212
RTU Protocol Service Reset	216
Backward Compatibility	217

Parameter Input Interface in Setup Web Pages

Setup Page

Setup

- Communication
 - Channel Parameters
 - Modem
 - Parameters
 - Serial Port
 - Parameters
 - PPPoE
 - Parameters

- Channel
 - IEC-104 Server
 - Parameters
 - Session 0
 - Parameters
 - Sector 0
 - Parameters
 - Data Mapping
 - Events

Reset Communication

Export/Import files

Security

FTP

- Monitoring
- Control
- Diagnostics
- Maintenance
- Setup



Copyright © 2010, Schneider Automation SAS. All Rights Reserved.

Parameters Input Overview

Each parameter input field contains these basic parts:

- **Parameter Title:** The Parameter Title contains the name of the parameter. It includes the value unit within brackets (if applicable).
- **Input Field:** Enter the desired parameter value in this field.
- **Parameter Description:** Provides a brief description of the parameter. It includes the data type of the parameter, valid scope setting, and default value.

NOTE: A reset parameter (or reboot of the module) is necessary to take into account any configuration changes (*see page 216*).

By default the parameter description is hidden. The description appears only when you place the cursor over the input field:

The screenshot shows a configuration interface with five input fields. A tooltip is displayed over the 'T3 Test Period (ms)' field. The fields and their values are:

Parameter	Value
T1 Ack Period (ms)	15000
T2 S Frame Period (ms)	10000
T3 Test Period (ms)	20000
K Value	12
W Value	8

The tooltip for 'T3 Test Period (ms)' contains the following text:

Parameter Description
Time to wait for ACK to a transmitted APDU (Type: integer, Min: 0, Max: 4294967295, Default: 15000)

Configuration Files Compatibility

The BMXNOR0200H module supports upward compatibility with previous version.

Consistency Checking

Support consistency checking in web configuration including uniqueness checking of CPU register address, relationship checking of relative parameters. The consistency checking is processed before user decide to change effective by click **Change** or **Add** button:

- If the value of the parameters does not abide by consistency checking, a parameter conflict dialog is popped up. It is only to show user the problem. Choose **Cancel** to cancel this configuration, and choose **OK** to go on this operation.
- The invalid parameter dialog is popped up to reject the configuration of the user.

Parameter conflict page for consistency checking:

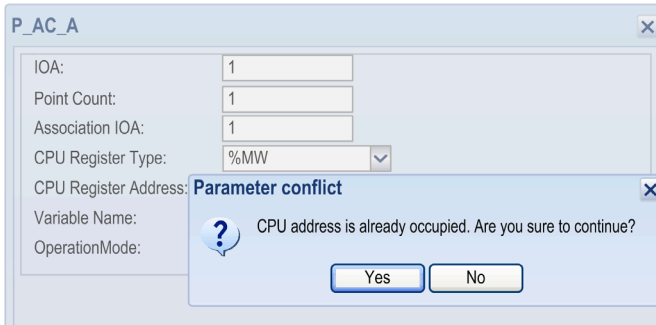

Detected invalid input page for consistency checking:

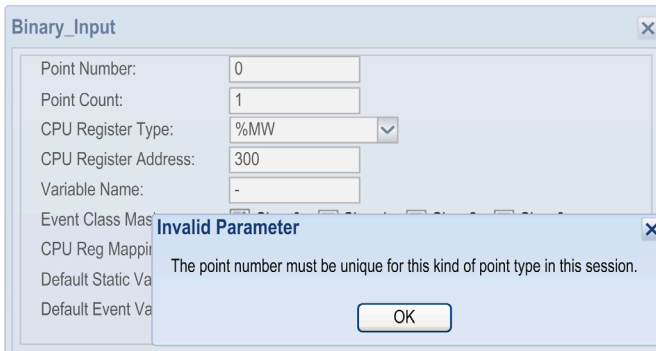

Gray Out Option Automatically

For the parameters conflicting with other parameters, they are disabled automatically once the relative parameter is enabled.

Screen of gray option:

The screenshot shows a web-based configuration window titled "Modem". Inside, there is a "Parameters" section. A red rectangular box highlights the following fields, which are grayed out (disabled):

- Connection Type: OnDemand
- Default Phone Index: 1
- Max Retry: 3
- Command Reg Address(%MW): 10000

Other visible fields include:

- Modem Type: Radio
- PPP Enable:

A "Change" button is located at the bottom right of the window.

Channel Configuration

Communication Setup

Before configuring the ports of the BMXNOR0200H module, select the link to be configured via the website.

Click **Communication** → **Channel Parameters** → **Add** :

Parameter	Value scope	Default value	Description
Channel ID	0...4	0	index of the channel
Protocol	IEC/DNP3	IEC(101,104)	protocol type
Network Type	TCP-IP/Raw Serial and for DNP3, TCP-UDP, and UDP-IP	TCP-IP	physical port type

Parameter	Value scope	Default value	Description
Mode	Master/Slave	Slave(Server)	role in network
IP Address	—	255.255.255.255	IP address of remote device (multiple address separate by semicolon).
Local Port	0...65535	2404	port of remote device
Connection Count	1...4	1	For IEC104 and DNP3 server: maximum number of clients connected to the server at one time.
	Protocol: IEC(101,104): 1...64 DNP3: 1...32	1	For IEC104 and DNP3 client: maximum number of servers connected to the client at one time.
Status Reg Type	%MW	%MW	channel status register type in CPU
Status Reg Start Address	0...32464	0	Start address of channel connection status register (32 bits) in CPU, for server that configured with more than one client, there is an independent status register for each client.

NOTE: When a module is in the slave/server mode, several clients (≤ 4) can be connected to the module. These clients have the same configuration except for the IP address. Configure the client number in the parameter **Connection Count**. At this time, four channels are displayed on the page. But only one is real, the others are displayed as virtual. When the user adds/removes a real channel, the operation affects all virtual channels.

NOTE: The choice between IEC 101 and IEC 104 depends on the combination of protocol, mode, and network in the communication settings.

NOTE: Master/slave is used in serial communication, but client/server is used in Ethernet communication.

The designations of the protocols are:

- IEC 60870-5-101 master/IEC 60870-5-101 slave
- IEC 60870-5-104 client/IEC 60870-5-104 server
- DNP3 master/DNP3 slave
- DNP3 Net client/DNP3 Net server

Multiple Protocols

The configuration supports multiple protocols in one module. IEC 101 master/IEC 104 server, IEC 104 client/IEC 104 server, DNP3 master/DNP3 Net server, DNP3 Net client/DNP3 Net server, only this combinations table is allowed. Do not run IEC and DNP3 at the same time within one module.

Case	1		2	
	Protocol	Max count	Protocol	Max count
1	DNP3 master	1	–	–
2	DNP3 NET master	1	–	–
3	IEC 101 master	1	–	–
4	IEC 104 master	1	–	–
5	–	–	DNP3 slave	1
6	–	–	DNP3 NET server	1
7	–	–	IEC 101 slave	1
8	–	–	IEC 104 server	1
9	DNP3 master	1	DNP3 NET server	1
10	DNP3 NET client	1	DNP3 NET server	1
11	IEC 101 master	1	IEC 104 server	1
12	IEC 104 client	1	IEC 104 server	1

Multi-server for IEC 104 client and DNP3 IP client

Only one client channel is allowed to configure in communication setting, but it can support up to 64 servers in 64 sessions (IEC 104) and 32 servers in 32 sessions (DNP3). Each session corresponds to one server. All sessions share the configuration of the common channel parameter. The feature is supported by both of IEC 104 client and DNP3 NET client.

This figure shows the communication configuration:

The screenshot shows a configuration window titled "Channel0" with the following settings:

- Channel ID: 0
- Protocol: DNP3
- Network Type: TCP-IP
- Mode: Master(Client)
- Connection Count: 1
- Status Reg Type: %MW
- Status Reg Start Address: 0

IP Address and port are set in session panel instead of communication setting. When **Connection Count** is more than 1, the corresponding status register is following **Status Reg Start Address**, each status occupies two words.

This figure shows the IP address and port configuration:

The screenshot shows a configuration window titled "DNP3 NET Client (Channel0 Session0)". It contains a "Parameters" section with the following fields:

IP Address:	255.255.255.255
Dest Port:	20000
Local Address:	3
Slave Address:	4
Default Response Timeout(ms):	30000

Below the parameters is an "Advanced Parameters" section which is currently collapsed. A "Change" button is located at the bottom right of the panel.

Only one IP is allowable in this panel.

This figure shows the session count:

The screenshot shows a configuration window titled "Channel0". It contains a "Parameters" section with the following field:

Session Count:	5
----------------	---

The "Session Count" field is highlighted with a red rectangular box. Below the parameters is an "Advanced Parameters" section which is currently collapsed. A "Change" button is located at the bottom right of the panel.

The session count may be up to 32 with same IP address for only one channel. For more than one connection, the session counter is same as the number of connections.

This figure shows the share channel parameters:

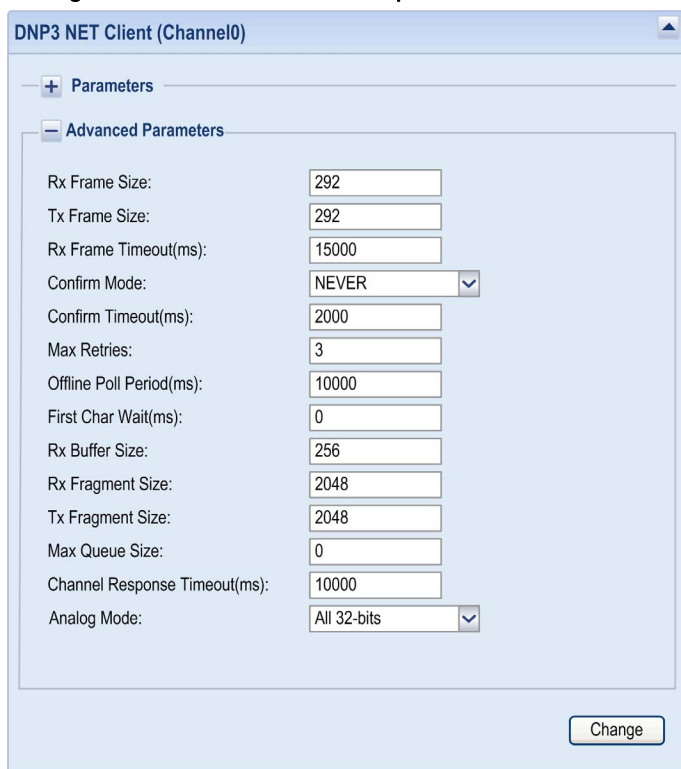

The screenshot displays the 'DNP3 NET Client (Channel0)' configuration window. It features a 'Parameters' section with a sub-section for 'Advanced Parameters'. The parameters are listed as follows:

Parameter	Value
Rx Frame Size:	292
Tx Frame Size:	292
Rx Frame Timeout(ms):	15000
Confirm Mode:	NEVER
Confirm Timeout(ms):	2000
Max Retries:	3
Offline Poll Period(ms):	10000
First Char Wait(ms):	0
Rx Buffer Size:	256
Rx Fragment Size:	2048
Tx Fragment Size:	2048
Max Queue Size:	0
Channel Response Timeout(ms):	10000
Analog Mode:	All 32-bits

A 'Change' button is located at the bottom right of the configuration window.

All connections (clients) to different servers share the common channel parameters listed above.

Serial Port Configuration

Introduction

To configure the module in serial mode, select **Setup → Serial Port → Parameters**.

NOTE: To configure a modem in serial link (serial mode or PPP), it is mandatory to configure the serial port.

Serial Configuration

The screenshot shows a web-based configuration interface for a serial port. The window is titled "Serial Port" and has a "Parameters" tab selected. The parameters are as follows:

- Physical Line: RS232
- Signals: Rx-Tx
- Delay Before Transmission: 0
- Delay After Transmission: 0
- Delay Between Transmissions: 0
- Baud Rate: 19200
- Data Bits: 8
- Stop Bits: 1
- Parity: None

A "Change" button is located at the bottom right of the configuration area.

Parameter	Value scope	Default value	Description
Physical Line	RS232/RS485	RS232	selects physical connection lines
Signals	<ul style="list-style-type: none"> ● Rx-Tx ● Rx-Tx+RTS-CTS ● Rx-Tx+RTS-CTS-DCE 	Rx-Tx	selects signal lines for communication
Delay Before Transmission (T1)	0...65535 (as the unit is 10 ms, the range is 0...655.35 s)	0	only used with DCE flow control algorithm; transmission delay after RTS is set
Delay After Transmission (T2)	0...65535 (as the unit is 10 ms, the range is 0...655.35 s)	0	only used with DCE flow control algorithm; time to reset RTS after transmission end

Parameter	Value scope	Default value	Description
Delay Between Transmissions (T3)	0...65535 (as the unit is 10 ms, the range is 0...655.35 s)	0	only used with DCE flow control algorithm; min. time between RTS reset and next RTS set (the delay depends on the application)
Baud Rate	300/600/1200/2400/4800/9600/19200/38400	19200	transmission speed of the serial port, bits per second
Data Bits	8	8	bits for data in one transmission unit
Stop Bits	1/2	1	bits to stop in one transmission unit
Parity	None/Odd/Even	None	parity mode

This chronogram shows the settable delays:

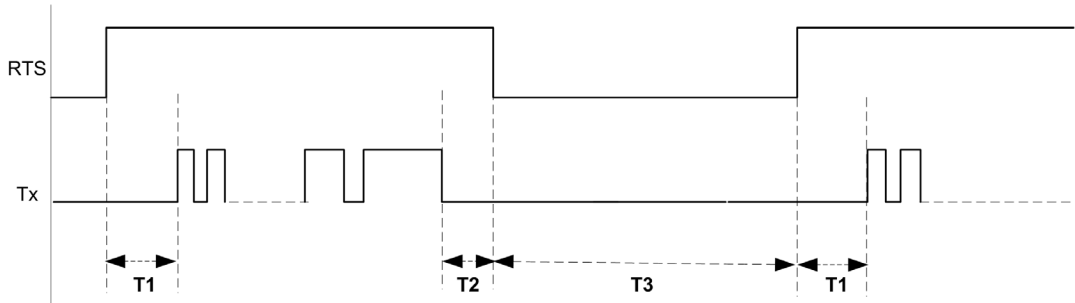

Modem Configuration

Select **Communication** → **Modem** → **Parameters**:

Parameter	Value scope	Default value	Description
Modem Type	None / Radio / PSTN / GSM / GPRS	None	selects Modem type
Connection Type	Permanent/ On Demand	On Demand	<ul style="list-style-type: none"> Permanent: connect modem automatically when module is power up On Demand: connect or disconnect modem according to CMD Reg in CPU
Default Phone Index	1...64	1	phone index in phone list: used when connection mode is permanent, or value in CPU phone index register is invalid
Max Retry	0...255	3	indicates the maximum number of retries to establish a connection.
Command Reg Address (%MW)	0...32464	0	start %MW address of 4 CPU modem registers which represent modem command and status for modem serial link. Or start address of 8 %MW registers, which represent modem command, status, local and remote IP address for modem PPP link.
PPP Enable	check box	checked	if enabled, PPP protocol is used for the modem connection

NOTE: When using RTU protocol (IEC 104/DNP3) via PSTN/GPRS or ADSL mode, the gateway IP address is replaced after connection is established. So it is not possible to route through Ethernet when the module is connected to the GPRS/PPPoE network.

GSM

Condition: **GSM** has been selected in the Modem screen.

Select **Communication** → **Modem** → **Modem GSM**:

Parameter	Value scope	Default value	Description
Init AT CMD	—	ATE0Q0S0=1&D0&S0&C0	custom AT commands specified by user - AT commands to initialize modem, which is an AT command string starting with AT
PIN Code	4-8 number	0000	PIN code for the SIM card
SMS Service Center	—	-	number of the service center for the SMS server - International format number of the service center for the SMS server, set symbol (-) if not specify it
SMS Type	PDU_7bits/ PDU_8bits	PDU_7bits	PDU_7bits: the message is encoded on 7 bits, and it is used to send text message composed of ASCII characters. It is supported in most of mobile phones. PDU_8bits: the message is encoded as 8 bits, and it is used to send data message. It depends on the brand of mobile phone, not all mobile phones support it.

GPRS

Condition: **GPRS** has been selected in the Modem screen.

Select **Communication** → **Modem** → **Modem GPRS**:

Parameter	Value scope	Default value	Description
Init AT Command	—	ATE0Q0S0=1&D0&S0&C0	custom AT commands specified by user - AT commands to initialize modem, which is an AT command string starting with AT
Access Point Name (APN)	—	-	name of the access point given by the service provider for GPRS
PIN Code	4 digits at least	0000	PIN code for the SIM card
SMS Service Center	—	-	number of the service center for the SMS server - International format number of the service center for the SMS server, set symbol (-) if not specify it
SMS Type	PDU_7bits/ PDU_8bits	PDU_7bits	PDU_7bits: the message is encoded on 7 bits, and it is used to send text message composed of ASCII characters. It is supported in most of mobile phones. PDU_8bits: the message is encoded as 8 bits, and it is used to send data message. It depends on the brand of mobile phone, not all mobile phones support it.
Username	—	USER	username of the APN given by the service provider
Password	—	USER	password of the APN given by the service provider, set symbol (-) if not specifying it
Local IP address	—	0.0.0.0	Local IP address for PPP client, and IP address is served by server if specifying 0.0.0.0.

PSTN

Condition: **PSTN** has been selected in the Modem screen.

Select **Communication** → **Modem** → **Modem PSTN**:

Parameter	Value scope	Default value	Description
Init AT CMD	—	ATE0Q0S0=1&D0&S0&C0	custom AT commands specified by user - AT commands to initialize modem, which is an AT command string starting with AT

PPP Server

Conditions: in the Modem screen, the modem type GSM or PSTN has been selected and the box PPP Enable has been checked.

Select **Communication** → **Modem** → **PPP Server**:

Parameter	Value scope	Default value	Description
Username for Server	—	USER	username of the remote device (only used for modem PPP as server mode)
Password for Server	—	USERUSER	password of the remote device (only used for modem PPP as server mode)
Local IP Address	—	0.0.0.0	IP address of the remote device
Allow Remote IP Address	check box	unchecked	whether allow calling device to specify its own IP address

Phone List

Select **Communication** → **Modem** → **Phone List**:

The screenshot shows the 'Phone List' configuration window. At the top, there are 'Remove' and 'Add' buttons. Below is a table with the following columns: Phone Index, Phone Number, Local IP, Username, Password, and Comment. A modal dialog titled 'Phone Index1' is open, showing input fields for each parameter:

- Phone Index: 1
- Phone number: 000000
- Local IP: 0.0.0.0
- Username: USER
- Password: *****
- Comment: Comment

Buttons for 'Add' and 'Cancel' are located at the bottom of the dialog.

Parameter	Value scope	Default value	Description
Phone Index	1...64	1	phone number index of the remote device
Phone Number	—	000000	phone number of the remote device
Local IP	—	0.0.0.0	IP address of the local device and IP address is served by provider if specifying 0.0.0.0. (only used for modem PPP as server mode)
Username	—	USER	username of the remote device (only used for modem PPP as server mode)
Password	—	USERUSER	password of the remote device (only used for modem PPP as server mode)
Comment	—	Comment	comments from the user

Ethernet Port Configuration

PPPoE Setup

The Ethernet port is configured via Control Expert. Nevertheless, in case of an ADSL modem the PPPoE protocol is used and the Ethernet port is configured via the Web site.

Click PPPoE setup:

Parameter	Value scope	Default value	Description
Enable PPPoE	check box	unchecked	enable PPPoE on modem connection
Connection Type	Permanent/On Demand	Permanent	<ul style="list-style-type: none"> Permanent: connect modem automatically when module is power up On Demand: connect or disconnect modem according to CMD Reg in CPU
CPU Reg Address	0...32264	0	start address of 8 %MW registers, which represent modem command, status, local and remote IP address
Username for Server	—	USER	username to connect with this PPP server
Password for Server	—	USERUSER	password to connect with this PPP server
Local IP address	—	0.0.0.0	specify PPPoE client IP address, and IP address is served by provider if specifying 0.0.0.0

RTU Protocol Parameters

Introduction

You can enter values for protocol parameters in the input fields on the Web page. Protocol parameters are either basic or advanced:

- **Parameters:** basic parameters can be modified in each user application.
- **Advanced Parameters:** it is not recommended to change advanced parameters unless a change is required by a specific application requirement.

These parameters allow you to set up RTU applications with the BMXNOR0200H module:



Time Zone Configuration

Web Site Configuration

The time zone is configurable only for the DNP3 master and slave, which have the same options as NTP configurations in Control Expert. The purpose is to set time zone when the RTU module has not specified a time zone in the NTP configuration or the NTP is disabled.

Setup

- Communication
 - Channel Parameters
 - Modem
 - Parameters
 - Modem PSTN
 - Phone List
 - Serial Port
 - Parameters
 - PPPoE
 - Parameters
 - TimeZone
 - Parameters

Parameters

Time Zone:

Automatically clock for daylight saving change:

Parameter	Value scope	Default value	Description
Time Zone	Custom timezone (GMT-12:00)Dateline Standard Time (GMT0)Greenwich Mean Time	(GMT0)Greenwich Mean Time	The default format is Universal Time Coordinated (UTC). Optionally it can be configured to use a local time zone. If it mismatches with the time zone configuration in Control Expert, keep as the Control Expert setting.
Automatically clock for daylight saving change:	check box	unchecked	the module automatically adjust the time change in the spring and fall

Control Expert Configuration

If NTP configuration is enabled in Control Expert as shown in the figure, the parameter in the Web page has the same configuration as NTP when the DNP3 protocol is created.

This figure shows the time zone in Control Expert:

NTP Configuration

If NTP configuration is different from time zone in the Web page, an indicator label displays explicitly in the Web page.

NOTE: The NTP configuration has higher priority, which means that the RTU module uses the time zone of NTP, not the setting configured in the Web page if they mismatch with each other.

This figure shows the time zone in the Web site:

Module and Protocols Configuration File

Introduction

Using this utility, the user exports or imports configuration parameters and data mapping files.

You can save the module and protocols configuration parameters in an *.XML file to a local storage media or upload a previously saved configuration file.

You can export RTU data object mapping to an *.XSY symbol file that can be imported into your application program in Control Expert.

Import/Export File

This figure shows the export data mapping:

DNP3 NET Client(Channel0 Session0) – Data Mapping						
Remove						
<input type="checkbox"/>	Type Identification	Point Number	Data Count	CPU Point Type	CPU Point Address	
<input type="checkbox"/>	Binary_Output_S...	0	1	%MW	0	
<input type="checkbox"/>	Frozen_Counter	0	10	%MW	200	

Frozen_Counter

Add

Import Configuration Parameters file

File Name:

Browse...

Export

Import

Right click [here](#) and select "Save Target As..." to export Data mapping XML file

- Open
- Open in New Tab
- Open in New Window
- Save Target As...
- Print Target
- Cut
- Copy
- Copy Shortcut
- Paste
- Add to Favorites...
- Properties

It provides an interface to edit/remove the collision parameter. User can edit the parameter by double clicking or remove it directly by clicking remove button.

This figure shows the import data mapping:

Select a type id...

Import Configuration Parameters file

File Name:

Right click [here](#) and select "Save Target As..." to export Data mapping XML file

DNP3 NET Server(Channel1 Session0) - Data Mapping - Import						
Remove						
<input type="checkbox"/>	Type Identification	IOA	Data Count	CPU Point Type	CPU Point Address	
<input type="checkbox"/>	Binary_Input	0	10	%MW	2000	

NOTE: It checks the consistency of protocols when importing data mapping. Only these combinations are allowed:

- DNP3 Net client/ server <-> DNP3 Net client/ server
- DNP3 master/ slave <-> DNP3 master/ slave
- DNP3 Net client/ server <-> DNP3 master/ slave
- IEC 101 master/ slave <-> IEC 101 master/ slave
- IEC 104 client/ server <-> IEC 104 client/ server
- IEC 101 master/ slave <-> IEC 104 client/ server

Exporting Locally

Follow these steps to export the configuration profile to a local place:

Step	Action	Comment
1	Right-click the hyperlink (Right click here...).	
2	Scroll to Save Target As.	The dialog box appears.
3	Select the local location to which the profile is stored.	

Importing to the Module

Follow these steps to import a saved configuration profile to the BMXNOR0200H module:

Step	Action	Comment
1	Click Browse .	This helps you select and save the configuration profile in an open dialog box.
2	Click Import .	The uploads the file and imports it.

NOTE: The newly imported configuration profile is not implemented until you reset the RTU services on the module.

Export of Data Mapping File for Control Expert

You can export RTU data object mapping to unlocated variables to an *.XSY symbol file that can be imported into your application program in Control Expert.

RTU Protocol Service Reset

Setup Tree

After any protocol parameters change (either by entering a new value or by importing a new parameter file), reset the RTU function in order to implement the changes. This figure shows the setup tree for an IEC 60870-5-104 server as an example:

Monitoring	Control	Diagnostics	Maintenance	Setup
				Setup
				Communication
				Channel
				IEC-104 Server
				Reset Communication
				Export/Import files
				Security
				FTP

The server is applying the change... Please wait for a while.

Copyright © 2010, Schneider Automation SAS. All rights reserved.

Backward Compatibility

Introduction

The BMXNOR0200H module supports upward compatibility from V1.0 to V1.5. RTU V1.5 has upwards compatibility including firmware and configuration files. All features from previous versions are supported by V1.7.

Event Backup Compatibility

Firmware and hardware supporting event backup:

Product Version	Firmware Version
PV03, PV07 or later	V1.5 or later

NOTE: If you are using PV03 hardware, the user interface allows you to set event backup parameters, but they are not applied if a loss of power occurs. A message appears on the configuration page indicating that the event backup feature is not supported by PV01, PV02, PV05, and PV06. Check your hardware version if you need this feature.

Screen of event backup:

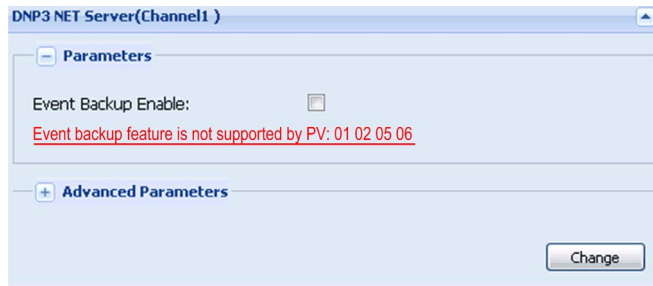

Firmware and Hardware Compatibility

NOTICE

UNEXPECTED EQUIPMENT BEHAVIOR

Do not load firmware V1.0 or V1.5 in a BMXNOR0200H with PV09 or later.

Failure to follow these instructions can result in equipment damage.

Firmware and hardware compatibility table:

Product Version	Firmware Version
PV01...PV08	V1.0 or V1.5
All	V1.6 or later

Website Configuration Files Compatibility

- New website configuration files are not supported in old firmware.
- Old website configuration files can be imported into new firmware, all parameters are effective. All new parameters are assigned as default values and configurable after importing the old configuration files.

Section 13.2

Web Site Configuration IEC

What Is in This Section?

This section contains the following topics:

Topic	Page
IEC 60870-5-101 Master RTU Protocol Parameters	220
IEC 60870-5-101 Slave RTU Protocol Parameters	227
IEC 60870-5-104 Client RTU Protocol Parameters	238
IEC 60870-5-104 Server RTU Protocol Parameters	243
IEC Data Object Mapping Page and Table	251
IEC Data Object Mapping	262
IEC Event Queue Setting	264
IEC 60870-5-101/104 Master/Client	266
IEC Data Length & Mapping Orientation	269
IEC Data Object Type Mapped to Control Expert EDT/DDT	270

IEC 60870-5-101 Master RTU Protocol Parameters

Introduction

Select IEC101-104 as Protocol, Master as Mode, and Raw Serial as Network Type.

Channel Parameters

Click **Setup** → **Channel** → **IEC-101 Master** → **Parameters**:

The screenshot shows a configuration window titled "IEC-101 Master(Channel0)". It has a "Parameters" section with three fields: "DL Address Length" is a dropdown menu set to "1"; "Use Balanced Mode" is an unchecked checkbox; and "Session Count" is a text input field containing "1". Below this section is an "Advanced Parameters" section which is currently collapsed. A "Change" button is located at the bottom right of the window.

Parameter	Value scope	Default value	Description
DL Address Length	0/1/2	1	indicates the octets used for data link address
Use Balanced Mode	check box	unchecked	indicates the usage of balanced or unbalanced mode
Session Count	1...32	1	indicates the maximum number of sessions on the channel

Configure the module's advanced parameters:

IEC-101 Master(Channel0)

+ Parameters

- Advanced Parameters

First Char Wait (ms):

Rx Buffer Size:

One Char Ack Allowed:

One Char Nack Allowed:

Rx Frame Timeout (ms):

Confirm Mode: ▼

Confirm Timeout (ms):

Max Retries:

Test Frame Period (ms):

Offline Poll Period (ms):

Incremental Timeout (ms):

Max Queue Size:

Parameter	Value scope	Default value	Description
First Char Wait (ms)	0...65535	0	indicates the minimum time between reception and transmission
Rx Buffer Size	0...256	256	indicates the receive buffer size of serial port (bytes)
One Char Ack Allowed	check box	unchecked	allows transmission of one character E5 instead of the fixed-length ACK message
One Char Nack Allowed	check box	unchecked	allows transmission of one-character response instead of the fixed-length NACK message, when no response data is available
Rx Frame Timeout (ms)	0...4294967295	15000	indicates the maximum waiting time for a complete frame after receiving frame sync.
Confirm Mode	NEVER SOMETIMES ALWAYS	NEVER	specifies when to request the link layer confirmation for variable sized frames that contain user data, which is not transmitted to the broadcast address

Parameter	Value scope	Default value	Description
Confirm Timeout (ms)	0...4294967295	2000	indicates the maximum waiting time for link level confirmation, if requested
Max Retries	0...255	2	indicates the retry count of the link layer confirmation timeouts
Test Frame Period (ms)	0...4294967295	0	specifies the period for transmitting the verification message, to prove that the remote device is still online in the balance mode
Offline Poll Period (ms)	0...4294967295	10000	specifies the period to re-establish transfer of an offline session
Incremental Timeout (ms)	0...4294967295	30000	indicates the incremental application layer timeout
Max Queue Size	0...65535	0	indicates the maximum request message number with a specific Application Specific Data Unit type and destination matching an outstanding request that will be queued on a master. 0: disabled queue 65535: unlimited queue

Session Parameters

Click **Setup** → **Channel** → **IEC-101 Master** → **Session** → **Parameters**:

The screenshot shows a configuration window titled "IEC-101 Master(Channel0 Session0)". It contains a "Parameters" section with the following fields:

- Sector Count:
- Data Link Address:
- CAA Size: (dropdown)
- IOA Size: (dropdown)
- COT Size: (dropdown)

Below the parameters is an "Advanced Parameters" section (collapsed) and a "Change" button.

Parameter	Value scope	Default value	Description
Sector Count	1...5	1	indicates the sectors for this session
Data Link Address	0...65535	3	specifies octets for data link address

Parameter	Value scope	Default value	Description
CAA Size	1...2	2	specifies octets for common address of Application Specific Data Unit
IOA Size	1...3	2	specifies octets of IOA
COT Size	1...2	1	specifies octets of COT

Configure the module's advanced parameters:

IEC-101 Master(Channel0 Session0)

+ Parameters

- Advanced Parameters

Originator address for COT:

Default Response Timeout (ms):

C1/C2 Pending Count:

Class 1 Poll Count:

Class 1 Pending Delay (ms):

Class 1 Poll Delay (ms):

Class 2 Pending Delay (ms):

Class 2 Poll Delay (ms):

Parameter	Value scope	Default value	Description
Originator address for COT	0...255	1	specifies the originator address for COT if COT length = 2
Default Response Timeout (ms)	0...4294967295	60000	indicates the default timeout for the confirmation of request
C1/C2 Pending Count	0...65535	10	indicates Class 1 and 2 polls when an application layer response is pending before next slave tried
Class 1 Polls Count	0...65535	10	indicates the maximum Class 1 polls to this session before next slave tried

Parameter	Value scope	Default value	Description
Class 1 Pending Delay (ms)	0...65535	0	For an unbalanced master, the minimum delay before a Class request will be sent if an application layer response is pending for this session. These parameters may be used to limit the bandwidth used.
Class 1 Poll Delay (ms)	0...4294967295	0	For an unbalanced master, the minimum delay before a Class request will be sent. These parameters may be used to limit the bandwidth used.
Class 2 Pending Delay (ms)	0...4294967295	500	For an unbalanced master, the minimum delay before a Class request will be sent if an application layer response is pending for this session. These parameters may be used to limit the bandwidth used.
Class 2 Poll Delay (ms)	0...4294967295	500	For an unbalanced master, the minimum delay before a Class request will be sent. These parameters may be used to limit the bandwidth used.

Sector Parameters

Click **Setup** → **Channelx** → **IEC-101 Master** → **Sessionx** → **Sectorx** → **Parameters**:

The screenshot shows a web interface for configuring an IEC-101 Master. The title bar reads "IEC-101 Master(Channel0 Session0 Sector0)". Under the "Parameters" section, there is a label "Common ASDU Address:" followed by a text input field containing the number "3". Below this section is an "Advanced Parameters" section which is currently collapsed. A "Change" button is located at the bottom right of the configuration area.

Parameter	Value scope	Default value	Description
Common ASDU Address	1...65535	3	indicates the common address of ASDU, 65535 is broadcast address.

Configure the module with advanced parameters:

The screenshot shows a web-based configuration window titled "IEC-101 Master(Channel0 Session0 Sector0)". Under the "Parameters" section, the "Advanced Parameters" are expanded. The settings are as follows:

- Clock Sync Mode: SYNC ONLY (dropdown menu)
- Propagation Delay (ms): 0 (text input)
- M_EI_NA GI:
- M_EI_NA Time sync:
- M_EI_NA CI:
- Online GI:
- Online Time Sync:
- Online CI:
- ACTTERM With CSE Setpoint:
- ACTTERM With Command:

A "Change" button is located at the bottom right of the configuration area.

Parameter	Value scope	Default value	Description
Clock Sync Mode	ACQUISITE LOAD SYNC ONLY	sync only	indicates the clock synchronization mode, this parameter only applies to actions performed automatically. ACQUISITE: Delay acquisition followed by load delay followed by clock sync LOAD: Load delay followed by clock sync SYNC ONLY: Clock sync only
Propagation Delay (ms)	0...65535	0	indicates the propagation delay if Clock Sync Mode is set to LOAD
M_EI_NA GI	check box	checked	specifies if general interrogation is performed after reception of M_EI_NA EOI message
M_EI_NA Time sync	check box	checked	specifies if Clock Sync is performed after reception of M_EI_NA EOI message
M_EI_NA CI	check box	unchecked	specifies if counter interrogation is performed after reception of M_EI_NA EOI message

Parameter	Value scope	Default value	Description
Online GI	check box	checked	specifies if general interrogation is performed whenever determines that a remote device has come online, available for devices that do not generate M_EI_NA EOImessage
Online Time Sync	check box	checked	specifies if Clock Sync is performed whenever determines that a remote device has come online, available for devices that do not generate M_EI_NA EOImessage
Online CI	check box	unchecked	specifies if counter interrogation is performed whenever determines that a remote device has come online, available for devices that do not generate M_EI_NA EOImessage
ACTTERM with CSE Setpoint	check box	unchecked	specifies whether to expect ACTTERM from slave upon completion of set point commands CSENA, CSENB and CSENC
ACTTERM with Command	check box	unchecked	specifies whether to expect ACTTERM from slave upon completion of commands other than set point commands

IEC 60870-5-101 Slave RTU Protocol Parameters

Introduction

Select IEC101-104 as Protocol, Slave as Mode, and Raw Serial as Network Type.

Channel Parameters

Click **Setup** → **Channel** → **IEC-101 Slave** → **Parameters**:

IEC-101 Slave(Channel0)

Parameters

DL Address Length: ▼

Use Balanced Mode:

Event Backup Enable:

Event Time Quality: ▼

Session Count:

Event backup feature is not supported by PV: 01 02 05 06

Advanced Parameters

Parameter	Value scope	Default value	Description
DL Address Length	1...2	1	indicates the bytes used for data link address
Use Balanced Mode	check box	unchecked	indicates the usage of balanced or unbalanced mode
Event Backup Enable	check box	unchecked	indicates whether to backup event on loss of power
Event Time Quality	Invalid, Original Quality	Original Quality	When restoring backup events after power restoration, the time quality is forced to <ul style="list-style-type: none"> invalid with Forcing Invalid the original quality with Original Quality NOTE: The box Event Backup Enable must be checked beforehand
Session Count	1...32	1	indicates the maximum number of sessions on the channel

Configure the module's advanced parameters:

The screenshot shows a web-based configuration window titled "IEC-101 Slave(Channel0)". It features a "Parameters" section with a sub-section for "Advanced Parameters". The parameters are as follows:

- First Char Wait (ms): 0
- Rx Buffer Size: 256
- One Char Ack Allowed:
- One Char Nack Allowed:
- Rx Frame Timeout (ms): 15000
- Confirm Mode: ALWAYS (dropdown menu)
- Confirm Timeout (ms): 2000
- Max Retries: 2
- Test Frame Period (ms): 0
- Offline Poll Period (ms): 10000
- Incremental Timeout (ms): 30000

A "Change" button is located at the bottom right of the configuration area.

Parameter	Value scope	Default value	Description
First Char Wait (ms)	0...65535	0	indicates the minimum time between reception and transmission
Rx Buffer Size	0...256	256	indicates the receive buffer size of serial port (bytes)
One Char Ack Allowed	check box	unchecked	allows transmission of one-character E5 instead of the fixed-length ACK message
One Char Nack Allowed	check box	unchecked	allows transmission of one-character response instead of the fixed-length NACK message, when no response data is available
Rx Frame Timeout (ms)	0...4294967295	15000	indicates the timeout of waiting for a complete frame after the receiving frame synchronization

Parameter	Value scope	Default value	Description
Confirm Mode	NEVER/SOMETIMES/ ALWAYS	ALWAYS	specifies when to request the link layer confirmation for variable sized frames that contain user data, which is not transmitted to the broadcast address
Confirm Timeout (ms)	0...4294967295	2000	indicates the maximum waiting time for link level confirmation, if requested
Max Retries	0...255	2	indicates the retry count of the link layer confirmation time-outs
Test Frame Period (ms)	0...4294967295	0	specifies the period for transmitting the verification message, to prove that the remote device is still online in the balance mode
Offline Poll Period (ms)	0...4294967295	10000	specifies the period to re-establish transfer of an offline session
Incremental Timeout (ms)	0...4294967295	30000	indicates the incremental application layer time-out

Session Parameters

Click **Setup** → **Channel** → **IEC-101 Slave** → **Session** → **Parameters**:

IEC-101 Slave(Channel0 Session0)

Parameters

Data Link Address:

CAA Size:

IOA Size:

COT Size:

Sector Count:

Advanced Parameters

Parameter	Value scope	Default value	Description
Data Link Address	0...65535	3	indicates bytes for the data link address
CAA Size	1...2	2	specifies bytes for common address of Application Specific Data Unit
IOA Size	1...3	2	specifies bytes of IOA
COT Size	1...2	1	specifies bytes of COT
Sector Count	1...5	1	indicates sectors for this session

Configure the module's advanced parameters:

The screenshot shows a web-based configuration window titled "IEC-101 Slave(Channel0 Session0)". It features a "Parameters" section with a sub-section for "Advanced Parameters". Two input fields are visible: "Max ASDU Size" with a value of 252, and "Max Poll Delay (ms)" with a value of 20000. A "Change" button is located at the bottom right of the window.

Parameter	Value scope	Default value	Description
Max ASDU Size	0...252	252	indicates the maximum size of an Application Specific Data Unit
Max Poll Delay (ms)	0...4294967295	20000	indicates the maximum time between link polls before the unbalanced slave is declared offline

Sector Parameters

Click **Setup** → **Channel** → **IEC-101 Slave** → **Session** → **Sector** → **Parameters**:

The screenshot shows a web-based configuration window titled "IEC-101 Slave(Channel0 Session0 Sector0)". It features a "Parameters" section with several input fields and dropdown menus: "Common ASDU Address" (3), "Cyclic Message Interval (ms)" (10000), "Background Period (ms)" (20000), "DefaultResponse Timeout" (60000), "Send Clock Sync Events" (checkbox), "Read Time Format" (None), "C_RD_NA Measurands Time Format" (None), and "C_IC_NA Time Format" (None). A "Change" button is located at the bottom right of the window.

Parameter	Value scope	Default value	Description
Common ASDU Address	1...65535	3	indicates the common address of ASDU, 65535 is broadcast address
Cyclic Message Interval (ms)	0...4294967295	10000	specifies the number of milliseconds between cyclic updates
Background Period (ms)	0...4294967295	20000	specifies the period to generate background scan data on this sector
Default Response Timeout (ms)	0...4294967295	60000	indicates the default timeout for the confirmation of request
Send Clock Sync Events	check box	unchecked	controls if spontaneous clock synchronization events are transmitted to the master. The time format is CP24
Read Time Format	None/ CP24/ CP56	None	specifies the completeness time format for respond to C_RD_NA
C_RD_NA Measurands Time Format	None/ CP24/ CP56	None	specifies the time format for respond to C_RD_NA
C_IC_NA Time Format	None/ CP24/ CP56	None	specifies the time stamp format in response of C_IC_NA

Configure the module with advanced parameters:

Parameter	Value scope	Default value	Description
Select Timeout (ms)	0...4294967295	5000	specifies the period after which a previously received selection is timed-out. An execute command must be received before the time-out in order to be valid.
ACTTERM with CSE Setpoint	check box	checked	specifies if ACT TERM is transmitted upon completion of the set point commands: C_SE_NA, C_SE_NB, C_SE_NC, C_SE_TA, C_SE_TB, C_SE_TC
ACTTERM with Command	check box	checked	specifies if ACT TERM is transmitted upon completion of commands, other than the set point commands.

1: This feature is available with firmware V1.7 or later.

Parameter	Value scope	Default value	Description
Clock Valid Period (ms)	0...4294967295	86400000	specifies the period for which the system clock remains valid after a clock synchronization. If this period expires without a clock synchronization, all times are reported invalid.
Delete Oldest Event	check box	unchecked	specifies if the oldest event is removed from the event queue when buffer is full and a new event comes. Checked: Remove the oldest event. Unchecked: Ignore the new event.
Short Pulse Duration	0...4294967295	100	specifies the width of the pulse in milliseconds
Long Pulse Duration	0...4294967295	1000	specifies the width of the pulse in milliseconds
Counter Mode	Freeze On Demand Local Freeze Only Local Freeze and Reset	Freeze On Demand	specifies the mode of freezing counter To support Mode A or Mode B, select either Local Freeze Only or Local Freeze and Reset. To support Mode C or Mode D, select Freeze On Demand.
Auto Local Freeze ⁽¹⁾	Auto Enabled Control by App	Auto Enabled	specifies the local freeze start and stop conditions Behavior: Auto Enabled: Local freeze starts automatically after BMXNOR0200H startup or restart. Control by App: Local freeze is configured by CPU application. Use CUSTOM_CMD (<i>see page 236</i>) data structure.
Freeze Period(Grp-G) ⁽¹⁾	0...4294967295	2000	specifies the period (in milliseconds) at which to freeze the counter automatically on all the groups. It only takes effect on local freeze. Value 0 disables freezing.
Freeze Period(Grp-1) ⁽¹⁾	0...4294967295	2000	specifies the period (in milliseconds) at which to freeze the counter automatically on group 1. It only takes effect on local freeze. Value 0 disables freezing.
Freeze Period(Grp-2) ⁽¹⁾	0...4294967295	2000	specifies the period (in milliseconds) at which to freeze the counter automatically on group 2. It only takes effect on local freeze. Value 0 disables freezing.
Freeze Period(Grp-3) ⁽¹⁾	0...4294967295	2000	specifies the period (in milliseconds) at which to freeze the counter automatically on group 3. It only takes effect on local freeze. Value 0 disables freezing.
1: This feature is available with firmware V1.7 or later.			

Parameter	Value scope	Default value	Description
Freeze Period(Grp-4) ⁽¹⁾	0...4294967295	2000	specifies the period (in milliseconds) at which to freeze the counter automatically on group 4. It only takes effect on local freeze. Value 0 disables freezing.
Summer Bit	check box	unchecked	specifies whether to manage the summer bit of time stamp which comes from an external device or CPU. Effective only when Daylight Saving Time is enabled
CMD Queue Size	1...128	1	specifies the size of the command queue to process in parallel for each point type
C_DC Impulse	Indeterminate State Determinate State	Determinate State	specifies whether the final state is in valid state or Indeterminate state. Behavior: Determinate State: only ON and OFF are valid states, the final state is ON or OFF after impulse. Indeterminate State: the final state is 0 after executing any impulse.
Data Synch Mode	Cyclic Synch Synch On Demand	Cyclic Synch	specifies how the data are synchronized: either cyclically or when the slave station receives a request from the master (see note); it is used only by data of type C_SE_NA, C_SE_NB, C_SE_NC and C_BO_NA
PLC State ⁽¹⁾	No Impact Quality Impact Quality	No Impact Quality	for non-routing points, specifies if the PLC state modifies or not the quality bit when quality is required by the master. Behavior: No Impact Quality: PLC state has no effect on the quality bit. Impact Quality: PLC state has an effect on the quality bit. A PLC in STOP state or a PLC missing generates an invalid quality bit. A PLC in RUN state generates a valid quality bit.
1: This feature is available with firmware V1.7 or later.			

NOTE: Only %MW and %M control points are supported in the Synch On Demand mode.

Counter Mode for Local Freeze and Freeze On Demand

Configuration for Counter Mode:

Counter Mode	M_IT Events Configured	M_IT Events Not Configured
Local Freeze	Mode A	Mode B
Freeze On Demand	Mode D	Mode C

NOTE: In mode Local Freeze and Reset, the counter is automatically frozen at the value 0.

NOTE: If counter events buffer is configured, Mode A is set by default. A mixed counter event mode is not supported. Only one counter event mode is supported at a time.

The `Freeze_Period(Grp-x)` parameter can be configured in milliseconds to freeze automatically for Mode A or Mode B. The frozen counter is reported spontaneously with valid events.

NOTE: The Counter event buffer must be configured for Mode A in case of an event loss. You can enable to delete oldest events in order to prevent new events from being lost.

CUSTOM_CMD Data Structure

CUSTOM_CMD (DWORD):

Name	Type	Word	Description
Command	WORD	0	Start or stop local freezing.
Status	WORD	1	Provides the freezing command status for each group.

Command (WORD):

Name	Type	Bit	Description
Command	BOOL	0	Global group control. Bit value: 0 : Stop freezing. 1 : Start freezing.
	BOOL	1	Group 1 control. Bit value: 0 : Stop freezing. 1 : Start freezing.
	BOOL	2	Group 2 control. Bit value: 0 : Stop freezing. 1 : Start freezing.
	BOOL	3	Group 3 control. Bit value: 0 : Stop freezing. 1 : Start freezing.
	BOOL	4	Group 4 control. Bit value: 0 : Stop freezing. 1 : Start freezing.
	-	5...15	Any value change triggers the command (start or stop freezing)

Status (WORD):

Name	Type	Bit	Description
Status	BOOL	0	Global group status. Bit value: 0: Freezing is disabled. 1: Freezing is enabled.
	BOOL	1	Group 1 status. Bit value: 0: Freezing is disabled. 1: Freezing is enabled.
	BOOL	2	Group 2 status. Bit value: 0: Freezing is disabled. 1: Freezing is enabled.
	BOOL	3	Group 3 status. Bit value: 0: Freezing is disabled. 1: Freezing is enabled.
	BOOL	4	Group 4 status. Bit value: 0: Freezing is disabled. 1: Freezing is enabled.
	–	5...15	Freezing execution status. Group of bits value: 0: Freezing command executed. 1: Freezing command not executed.

Daylight Saving Time and Summer Standard Time

The Daylight Saving Time (DST) is an optional feature which can be configured in the time zone web page (disabled by default):

NOTE: The Summer Bit is not supported in CP24Time2a.

IEC 60870-5-104 Client RTU Protocol Parameters

Introduction

Select IEC101-104 as Protocol, Master as Mode, and TCP-IP as Network Type.

Channel Parameters

Click **Setup** → **IEC-104 Client** → **Channel** → **Parameters**:

Parameter	Value scope	Default value	Description
T1 Ack Period (ms)	0...4294967295	15000	specifies the waiting time for ACK to a transmitted APDU
T2 S Frame Period (ms)	0...4294967295	10000	specifies the waiting time before transmitting the supervisory APDU ACK
T3 Test Period (ms)	0...4294967295	20000	specifies the idle time before transmitting the TEST APDU
K Value	1...12	12	indicates the maximum transmitted APDUs that are not acknowledged
W Value	0...32767	8	indicates the maximum received APDUs that are not acknowledged
Session Count	1...32	1	indicates the maximum number of sessions on the channel

NOTE: Limitations: $T2 \text{ S Frame Period} < T1 \text{ Ack Period}$ and $W \text{ Value} < 2/3 K \text{ Value}$.

Configure the module's advanced parameters:

The screenshot shows a web-based configuration window titled "IEC-104 Client(Channel0)". It has a "Parameters" section with a sub-section for "Advanced Parameters". The parameters are as follows:

Parameter	Value
First Char Wait (ms):	0
Rx Buffer Size:	256
Offline Poll Period (ms):	10000
Incremental Timeout (ms):	30000
Max Queue Size:	0

A "Change" button is located at the bottom right of the configuration window.

Parameter	Value scope	Default value	Description
First Char Wait (ms)	0...65535	0	indicates the minimum time between reception and transmission
Rx Buffer Size	0...256	256	indicates the received buffer size of serial port
Offline Poll Period (ms)	0...4294967295	10000	specifies the period an offline attempts to re-establish communication
Incremental Timeout (ms)	0...4294967295	30000	indicates the incremental application layer time-out
Max Queue Size	0...65535	0	indicates the maximum request message number with specific Application Specific Data Unit type in the transmission queue

Session Parameters

Click **Setup** → **IEC-104 Client** → **Channel** → **Session0** → **Parameters**:

Parameter	Value scope	Default value	Description
IP Address	255.255.255.255	192.168.0.1	indicates the IP address of remote device
Port	0..65535	2404	indicates the TCP port of remote device
Sector Count	1...5	1	indicates the sectors for this slave
COT Size	2	2	indicates octets of COT

Configure the module with advanced parameters:

Parameter	Value scope	Default value	Description
Originator Address for COT	0...255	1	specifies the originator address for COT, if the COT length is equal to 2
Default Response Timeout (ms)	0...4294967295	3000	indicates the default time-out for confirmation of request

Sector Parameters

Click **Setup** → **IEC-104 Client** → **Channel** → **Session0** → **Sector0** → **Parameters**:

IEC-104 Client(Channel0 Session0 Sector0)

Parameters

Common ASDU Address:

Advanced Parameters

Change

Parameter	Value scope	Default value	Description
Common ASDU Address	1...65535	3	indicates the common address of ASDU, 65535 is broadcast address.

Configure the module with advanced parameters:

IEC-104 Client (Channel1 Session0 Sector0)

Parameters

Advanced Parameters

M_EI_NA GI:

M_EI_NA Time sync:

M_EI_NA CI:

Online GI:

Online Time Sync:

Online CI:

ACTTERM With CSE Setpoint:

ACTTERM With Command:

Command With Time Tag:

Parameter Description
Whether the control command follow time tag. (Default: unchecked)

Change

Parameter	Value scope	Default value	Description
M_EI_NA GI	check box	checked	specifies if the general interrogation is performed after receiving the M_EI_NA EOI message
M_EI_NA Time sync	check box	checked	specifies if the clock synchronization is performed after receiving the M_EI_NA EOI message
M_EI_NA CI	check box	unchecked	specifies if the counter interrogation is performed after receiving M_EI_NA EOI message
Online GI	check box	checked	specifies if the general interrogation is performed whenever the M_EI_NA EOI message is received
Online Time Sync	check box	checked	specifies if the clock synchronization is performed whenever the M_EI_NA EOI message is received
Online CI	check box	unchecked	specifies if the counter interrogation is performed whenever the M_EI_NA EOI message is received
ACTTERM with CSE Setpoint	check box	unchecked	specifies if ACTTERM is expected from slave upon completion of set point commands
ACTTERM with Command	check box	unchecked	specifies if ACTTERM is expected from slave upon completion of commands other than set point commands
Command with Time Tag	check box	unchecked	specifies if the control command follows the time tag

IEC 60870-5-104 Server RTU Protocol Parameters

Introduction

Select IEC101-104 as Protocol, Slave as Mode, and TCT-IP as Network Type.

Channel Parameters

Click **Setup** → **Channel** → **IEC-104 Server** → **Parameters**:

IEC-104 Server(Channel0)

Parameters

T1 Ack Period(ms): 15000

T2 S Frame Period(ms): 10000

T3 Test Period(ms): 20000

K Value: 12

W Value: 8

Event Backup Enable:

Event Restore Mode: Main Channel

Event Time Quality: Original Quality

Event backup feature is not supported by PV: 01 02 05 06

Advanced Parameters

Change

Parameter	Value Scope	Default Value	Description
T1 Ack Period (ms)	0...4294967295	15000	specifies the waiting time for ACK to a transmitted APDU
T2 S Frame Period (ms)	0...4294967295	10000	specifies the waiting time before sending supervisory APDU ACK
T3 Test Period (ms)	0...4294967295	20000	specifies the idle time before sending TEST APDU
K Value	1...12	12	indicates the maximum transmitted APDUs that are not acknowledged
W Value	0...32767	8	indicates the maximum received APDUs that are not acknowledged
Event Backup Enable	check box	unchecked	indicates whether or not to backup event on loss of power

Parameter	Value Scope	Default Value	Description
Event Restore Mode	Main channel / All channels	Main Channel	indicates on which channel to restore events to
Events Time Quality	Original Quality/ Forcing Invalid	Original Quality	indicates which quality format the events will restore to

NOTE: Limitations: T2 S Frame Period < T1 Ack Period and W Value < 2/3 K Value.

Configure the module's advanced parameters:

The screenshot shows a configuration window titled "IEC-104 Server(Channel0)". Under the "Parameters" section, the "Advanced Parameters" are expanded. The following parameters are visible:

- First Char Wait (ms): 0
- Rx Buffer Size: 256
- Offline Poll Period (ms): 10000
- DiscardFramesOnDisconnect:
- Incremental Timeout (ms): 30000

A "Change" button is located at the bottom right of the configuration area.

Parameter	Value Scope	Default Value	Description
First Char Wait (ms)	0...65535	0	indicates the minimum time between reception and transmission
Rx Buffer Size	0...256	256	indicates the received buffer size of serial port
Offline Poll Period (ms)	0...4294967295	10000	specifies the period of a session that is offline attempts to re-establish communication
Discard Frames on Disconnect	check box	unchecked	Setting this <code>TMWDEFS_TRUE</code> on a slave will cause received unacknowledged responses (Information Frames) to be discarded when the TCP connection is broken. If a slave has sent responses, but has not yet received a link layer ack, and the master is restarted and reconnects, the old unacknowledged responses will be resent.
Incremental Timeout (ms)	0...4294967295	30000	indicates the incremental application layer time-out

Session Parameters

Click **Setup** → **Channelx** → **IEC-104 Server** → **Sessionx** → **Parameters**:

IEC-104 Server (Channel0 Session0)

Parameters

COT Size:

Sector Count:

Advanced Parameters

Change

Parameter	Value Scope	Default Value	Description
COT Size	2	2	indicates the bytes for COT
Sector Count	1...5	1	indicates sectors for this slave

Configure the module with advanced parameters:

IEC-104 Server(Channel0 Session0)

Parameters

Advanced Parameters

Max ASDU Size:

Change

Parameter	Value Scope	Default Value	Description
Max ASDU Size	0...249	249	indicates the maximum size of an Application Specific Data Unit

Sector Parameters

Click **Setup** → **Channelx** → **IEC-104 Server** → **Sessionx** → **Parameters**:

The screenshot shows a web-based configuration window titled "IEC-104 Server(Channel0 Session0 Sector0)". It contains a "Parameters" section with the following settings:

- Common ASDU Address: 3
- Cyclic Message Interval (ms): 10000
- Background Period (ms): 20000
- Read Time Format: None

Below the parameters is a section for "Advanced Parameters" which is currently collapsed. A "Change" button is located at the bottom right of the window.

Parameter	Value Scope	Default Value	Description
Common ASDU Address	1...65535	3	indicates the common address of ASDU, 65535 is broadcast address.
Cyclic Message Interval (ms)	0...4294967295	10000	specifies the number of milliseconds between cyclic updates
Background Period	0...4294967295	2000	specifies the period to generate background scan data on this sector
Read Time Format	None/ CP24/ CP56	None	specifies the completeness time format for responding to C_RD_NA

Configure the module with advanced parameters:

IEC-104 Server(Channel0 Session0 Sector0)

Parameters

Advanced Parameters

Select Timeout(ms):

Default Response Timeout:

ACTTERM With C_SE Setpoint:

ACTTERM With Command:

Clock Valid Period(ms):

Send Clock Sync Events:

Max Command Age(ms):

Delete Oldest Events:

Short Pulse Duration:

Long Pulse Duration:

Counter Mode:

Auto Local Freeze:

Freeze Period(Grp-G):

Freeze Period(Grp-1):

Freeze Period(Grp-2):

Freeze Period(Grp-3):

Freeze Period(Grp-4):

Summer Bit:

CMD Queue Size:

C_DC Impulse:

Data Synch Mode:

Routing Offline:

PLC State:

Parameter	Value scope	Default value	Description
Select Timeout_ (ms)	0...4294967295	50000	specifies the period after which a previously received selection is timed-out
Default Response Timeout)	0...4294967295	6000	Responses that are no longer relevant are removed from queue. For example, if the master is turned off before a response is acknowledged and then the master is restarted later, this timeout value will be used to delete old responses.
ACTTERM with CSE Setpoint	check box	checked	specifies if ACT TERM is transmitted upon completion of the set point commands
1: This feature is available with firmware V1.7 or later.			

Parameter	Value scope	Default value	Description
ACTTERM with Command	check box	checked	specifies if the ACT TERM is sent upon completion of commands other than the set point commands
Clock Valid Period (ms)	0...4294967295	86400000	specifies the period for which the system clock remains valid after a clock synchronization. If this period expires without a clock synchronization all times will be reported invalid.
Send Clock Sync Events	check box	unchecked	controls if the spontaneous clock synchronization events are sent to the master.
Max Command Age (ms)	0...600000	30000	indicates the maximum time delta at which commands are accepted. The command time tag is checked and if the elapsed time is greater than <i>Max Command Age (ms)</i> , the command gets no response. Value 0 indicates that the command time tag is not checked.
Delete Oldest Event	check box	unchecked	specifies if the oldest event is removed from the event queue when buffer is full and a new event comes. Checked: Remove the oldest event. Unchecked: Ignore the new event.
C_RD_NA Measurands Time Format	None/ CP24/ CP56	None	specifies the time format for responding to C_RD_NA
C_IC_NA Time Format	None/ CP24/ CP56	None	specifies the time stamp format in response of C_IC_NA
Short Pulse Duration	0...4294967295	100	specifies the width of the pulse in milliseconds
Long Pulse Duration	0...4294967295	1000	specifies the width of the pulse in milliseconds
Counter Mode	Freeze On Demand Local Freeze Only Local Freeze and Reset	Freeze On Demand	specifies the mode of freezing counter To support Mode A or Mode B, select either Local Freeze Only or Local Freeze and Reset. To support Mode C or Mode D, select Freeze On Demand.
Auto Local Freeze ⁽¹⁾	Auto Enabled Control by App	Auto Enabled	specifies the local freeze start and stop conditions Behavior: Auto Enabled: Local freeze starts automatically after BMXNOR0200H startup or restart. Control by App: Local freeze is configured by CPU application. Use CUSTOM_CMD (<i>see page 236</i>) data structure.
1: This feature is available with firmware V1.7 or later.			

Parameter	Value scope	Default value	Description
Freeze Period(Grp-G) (1)	0...4294967295	2000	specifies the period (in milliseconds) at which to freeze the counter automatically on all groups. It only takes effect on local freeze. Value 0 disables freezing.
Freeze Period(Grp-1) (1)	0...4294967295	2000	specifies the period (in milliseconds) at which to freeze the counter automatically on group 1. It only takes effect on local freeze. Value 0 disables freezing.
Freeze Period(Grp-2) (1)	0...4294967295	2000	specifies the period (in milliseconds) at which to freeze the counter automatically on group 2. It only takes effect on local freeze. Value 0 disables freezing.
Freeze Period(Grp-3) (1)	0...4294967295	2000	specifies the period (in milliseconds) at which to freeze the counter automatically on group 3. It only takes effect on local freeze. Value 0 disables freezing.
Freeze Period(Grp-4) (1)	0...4294967295	2000	specifies the period (in milliseconds) at which to freeze the counter automatically on group 4. It only takes effect on local freeze. Value 0 disables freezing.
Summer Bit	check box	unchecked	specifies whether the summer bit of time stamp which comes from external device or CPU is managed. Effective only if Daylight Saving Time is enabled
CMD Queue Size	1...128	1	specifies the size of a command queue to process in parallel for each point type
C_DC Impulse	Indeterminate State Determinate State	Determinate State	specifies whether the final state is in valid state or Indeterminate state. Behavior: Determinate State: only ON and OFF are valid states, the final state is ON or OFF after impulse. Indeterminate State: the final state is 0 after executing any impulse.
Data Synch Mode	Cyclic Synch Synch On Demand	Cyclic Synch	specifies how the data are synchronized: either cyclically or when the server station receives a request from the master (see note); it is used only by data of type C_SE_NA, C_SE_NB, C_SE_NC and C_BO_NA
1: This feature is available with firmware V1.7 or later.			

Parameter	Value scope	Default value	Description
Routing Offline ⁽¹⁾	Valid Quality Invalid Quality	Valid Quality	<p>specifies if routing point quality depends on connection state with sub-slave or sub-server.</p> <p>Behavior:</p> <p>Valid Quality: Routing points quality does not change when connection is lost.</p> <p>Invalid Quality: Routing points quality is marked as invalid when connection is lost.</p>
PLC State ⁽¹⁾	No Impact Quality Impact Quality	No Impact Quality	<p>for non-routing points, specifies if the PLC state modifies or not the quality bit when quality is required by the master.</p> <p>Behavior:</p> <p>No Impact Quality: PLC state has no effect on the quality bit.</p> <p>Impact Quality: PLC state has an effect on the quality bit.</p> <p>A PLC in <i>STOP</i> state or a PLC missing generates an invalid quality bit.</p> <p>A PLC in <i>RUN</i> state generates a valid quality bit.</p>
<p>1: This feature is available with firmware V1.7 or later.</p>			

NOTE: Only %MW and %M control points are supported in the Synch On Demand mode.

IEC Data Object Mapping Page and Table

Data Object Mapping Page

This figure shows the dialog box for configuring the data object mapping for an item with the example data type M_SP for IEC 60870-5-101/104 slave/server:

The dialog box is titled "IEC-104 Client(Channel0 Session0 Sector0) – Data Mapping". It features a tree view on the left with the following structure:

- Setup
 - Communication
 - Channel Parameters
 - Modem
 - Parameters
 - Modem GSM
 - Phone List
 - Serial Port
 - Parameters
 - PPPoE
 - Parameters
 - Channel
 - IEC-104 Client
 - Parameters
 - Session 0
 - Parameters
 - Sector 0
 - Parameters
 - Data Mapping

The main area contains a table with the following data:

Type Identification	IOA	Data Count	CPU Point Type	CPU Point Address
M_SP	1	1	%MW	0

Below the table is a list of parameters to map to, with "M_SP" selected. The list includes:

- M_SP
- M_DP
- M_ST
- M_BO
- M_ME_A
- M_ME_B
- M_ME_C
- M_IT
- C_SC
- C_DC
- C_RC
- C_SE_A
- C_SE_B
- C_SE_C
- C_BO

Buttons for "Add", "Browse...", "Export", and "Import" are located to the right of the list.

This figure shows the dialog box for configuring the M_SP data object mapping for IEC 101/104 server/slave:

M_SP Single-point information [X]

IOA:

Point Count:

CPU Register Type: [v]

CPU Register Address:

Variable Name:

CPU Reg Mapping: [v]

Background scan Cyclic data transmission Event generation

Groups

Global

Group1 Group2 Group3 Group4

Group5 Group6 Group7 Group8

Group9 Group10 Group11 Group12

Group13 Group14 Group15 Group16

This figure shows the dialog box for configuring the M_SP data object mapping for IEC 101/104 client/master:

M_SP Single-point information

IOA:

Point Count:

CPU Register Type:

CPU Register Address:

Variable Name:

Store To CPU:

Event routing

Channel:

Session:

Sector:

IOA:

Background scan Cyclic data transmission Event generation

Groups

Global

Group1 Group2 Group3 Group4

Group5 Group6 Group7 Group8

Group9 Group10 Group11 Group12

Group13 Group14 Group15 Group16

Mapping Table

Depending on the data object type and the selected protocol profile, different configuration fields are required to define a data object mapping item. This table describes the parameters:

Title	Value scope	Default value	Description
IOA	1...16777215	1	indicates the Information Object Address of the object.
Point Count	1...5000	1	indicates the number of objects defined. The IOA of each object is in sequence from the first object address.
CPU Register Type	%M/%MW/Unlocated	%MW	indicates the register type in CPU to map points.
CPU Register Address	0...30000	0	indicates start address of the register in CPU. field only taken into account for located variables.
Variable Name	-	-	indicates the variable name of located or unlocated register

1: This feature is available with firmware V1.7 or later.

Title	Value scope	Default value	Description
Store To CPU	Value only Value with time Value with quality Value with quality and time	Value only	indicates the choice if the store time follows the value in the CPU registers.
CPU Reg Mapping	Value only Value with time Value with flag Value with flag and time	Value only	choice the event time stamp source. module: use the module time as time stamp of event. CPU regs: use the time stamp in CPU registers.
Event routing			
Channel	None/0/1	None	indicates the channel number to route.
Session	0	0	indicates the session number to route.
Sector	0/1/2/3/4	0	indicates the sector number to route.
IOA	1...16777215	1	indicates the Information Object Address to route.
Background scan	check box	unchecked	indicates that the background scan is enabled.
Cyclic data transmission	check box	unchecked	indicates that the cyclic data transmission is enabled.
Event generation ⁽¹⁾	check box	checked	indicates that events for points can be configured.
Groups			
Global/1/2/3/4/5/6/7/8/9/10/11/12/13/14/15/16/C/B	check box	Global	defines data objects group responding for interrogation command from master/client. It can be combination of options.
1: This feature is available with firmware V1.7 or later.			

%S and %SW

The configuration supports %S only for single point input, M_SP, and %SW only for analog input, M_ME_NA, for IEC slave.

NOTE: For %S and %SW, the CPU mapping does not support array due to the limits of the Control Expert.

Quality Bit/Flag Mapping

The website configuration supports quality bit/flag mapping to CPU register for monitor data-points for IEC master/slave.

NOTE: Use this feature in For `M_SP`, `M_DP`, `M_ST`, `M_ME`, `M_ME_B`, `M_ME_C`, and `M_BO`, `M_IT`.

The configuration reuses Timestamp Source in slave and Store To CPU in master, and expands two choices based on RTU V1.0. Master and slave have similar configuration pages for quality bits and flags.

NOTE:

- For master, keep the parameter name Store To CPU.
- For slave, change the name from Timestamp Source into CPU Reg. Mapping.

Behavior

- Only monitor point type support this configuration on website except `M_IT` (server/slave).
- If end user configures flag/quality bit in CPU register in slave, module does not manage the quality bits/flags internally any more. The RTU module generates event following quality bit/flag in CPU register, otherwise, RTU generates them automatically.
- In server/slave, the change of quality bits or flags in CPU can trigger to generate events just like value change.
- The length of quality bits or flag is 1 byte no matter how many bytes it is mapped in CPU register, the least byte is valid. Refer to memory allocation.

Quality bit definition:

Point	Flag definition	Options	Comments
M_SP(SIQ)	single point information	bit 0:0/off/1/on	not used
	reserved	bit 1:0	not used
		bit 2:0	
		bit 3:0	
	blocked	bit 4:0 (not blocked) /1 (blocked)	–
	substituted	bit 5:0 (not substituted) /1 (substituted)	
	not topical	bit 6:0 (topical) /1 (not topical)	
invalid	bit 7:0 (valid)/ 1 (invalid)		
M_DP(DIQ)	double point information	bit 0:1 (off)	not used
		bit 1:1 (on)	
	reserved	bit 2:0	not used
		bit 3:0	
	blocked	bit 4:0 (not blocked)/ 1 (blocked)	–
	substituted	bit 5:0 (not substituted)/ 1 (substituted)	
	not topical	bit 6:0 (topical)/ 1 (not topical)	
invalid	bit 7:0 (valid)/ 1 (invalid)		
M_ST M_BO M_ME_A M_ME_B M_ME_C(QDS)	overflow	bit 0:0 (no overflow) /1 (overflow)	–
	reserved	bit 1:1 (on)	not used
		bit 2:0	
		bit 3:0	
	blocked	bit 4:0 (not blocked) /1 (blocked)	–
	substituted	bit 5:0 (not substituted) /1 (substituted)	
	not topical	bit 6:0 (topical) /1 (not topical)	
invalid	bit 7:0 (valid) /1 (invalid)		
M_IT(sequence notation)	sequence number	bit 0...4:0...31	If the counter is frozen once, the sequence number increments 1.
	carry	bit 5/ 0 (no overflow) /1 (overflow)	not supported in slave
	counter adjusted	bit 6:0 (not adjusted) /1 (adjusted)	
	invalid	bit 7:0 (valid) /1 (invalid)	

Input Float Value as Scientific

The input float values, as Scientific, are supported.

Long and Short Pulses

The protocol specification defines a qualifier value that is set by the master to determine the duration of the sort or long pulse. This parameter defines the number of milliseconds to be associated with a short or long pulse command. The configuration supports `C_SC`, `C_DC`, and `C_RC` for IEC server/slave.

This figure shows the pulse duration configuration:

IEC-104 Server(Channel0 Session0 Sector0)

Parameters

Advanced Parameters

Select Timeout(ms):	5000
Default Response Timeout:	60000
ACTTERM With CSE Setpoint:	<input checked="" type="checkbox"/>
ACTTERM With Command:	<input checked="" type="checkbox"/>
Clock Valid Period(ms):	86400000
Send Clock Sync Events:	<input type="checkbox"/>
Max Command Age(ms):	30000
Delete Oldest Event:	<input type="checkbox"/>
Short Pulse Duration:	100
Long Pulse Duration:	1000

Parameter Description
Specify pulse's width in milliseconds
(Type: integer, Min: 0, Max: 4294967295, Default: 1000)

When client/master sends pulse command to server/slave, the pulse duration is defined by controlled station. So the short/Long pulse duration needs to be configured on the website, and they are effective for `C_SC`, `C_DC`, and `C_RC`.

- short pulse duration: 100 ms by default
- long pulse duration: 1000 ms by default

When configuring `C_SC`, `C_DC` and `C_RC` in server/slave, their default qualifier needs to be set. If you do not specify the client/master (qualifier is 0), the slave uses the pre-defined qualifier above.

This figure shows the qualifier configuration, the default qualifier is persistent output:

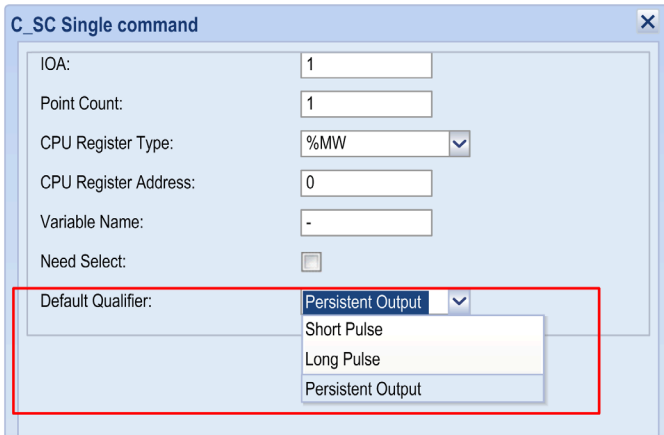

NOTE: C_SC,C_DC, and C_RC are triggered to update their value into CPU register only when server/slave receive command request from master, but not synchronized cyclically. Keep the corresponding CPU register not written by PLC application for end user.

Set Measured Value

Support P_ME_NA_1, P_ME_NB_1, P_ME_NC_1 to set the low limits, high limits and threshold of the measured, scaled and float value. The parameters of the measured points are activated immediately after IEC 101/104 slave receives the request from IEC 101/104 master.

P_ME_A, P_ME_B, and P_ME_C in IEC 101/104 are used to set the parameter of the measured point for M_ME_A, M_ME_B, and M_ME_C. In IEC 101/104 master, they are command to set parameter of the measured point, but in IEC 101/104 slave they are used to store current parameter value. It is necessary to specify the qualifier when configuration both in IEC 101/104 master and IEC 101/104 slave.

This figure shows the parameter point setting of IEC 101/104 master:

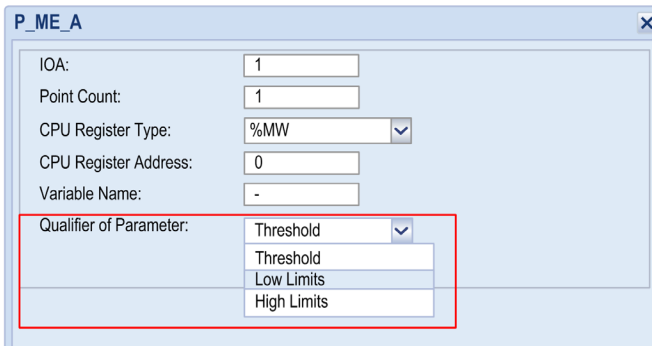

In IEC 101/104 slave, its configuration is same as IEC 101/104 master except IOA corresponds to the measure point such as M_ME_A IOA which is used to bind P_ME_A and M_ME_A.

This figure shows the parameter point setting of IEC 101/104 slave:

P_AC_A also need to bind a special IOA. It is different from P_ME_A, P_ME_B, P_ME_C, which may be set as any IOA for all monitor point types. P_AC_A is only used to activate/deactivate cyclic or period data transmission which is pre-defined in outstation. If outstation has no set neither of them, cyclic data transmission is activated or deactivated by default.

This figure shows the parameter point setting of IEC 101/104 slave:

Time Tag Parameter

Support control command with time tag (C_SC_TA, C_DC_TA, C_RC_TA, C_SE_TA, C_SE_TB, C_SE_TC, C_BO_TA) on IEC 104 server/IEC 104 client

This figure shows the max command age setting IEC 104 server:

The screenshot shows a web-based configuration window titled "IEC-104 Server(Channel0 Session0 Sector0)". It contains a "Parameters" section with a sub-section for "Advanced Parameters". The "Max Command Age(ms)" parameter is highlighted with a red box and is set to "30000". Other parameters include "Select Timeout(ms)" at 5000, "DefaultResponse Timeout" at 60000, "ACTTERM With CSE Setpoint" checked, "ACTTERM With Command" checked, "Clock Valid Period(ms)" at 86400000, "Send Clock Sync Events" unchecked, "Delete Oldest Event" unchecked, "Short Pulse Duration" at 100, and "Long Pulse Duration" at 1000. A "Change" button is located at the bottom right of the configuration area.

Parameter	Value
Select Timeout(ms)	5000
DefaultResponse Timeout	60000
ACTTERM With CSE Setpoint	<input checked="" type="checkbox"/>
ACTTERM With Command	<input checked="" type="checkbox"/>
Clock Valid Period(ms)	86400000
Send Clock Sync Events	<input type="checkbox"/>
Max Command Age(ms)	30000
Delete Oldest Event	<input type="checkbox"/>
Short Pulse Duration	100
Long Pulse Duration	1000

If a time tagged command is older than this period then the control operation is not taken. The default value for this field is 30,000 milliseconds. Values: 0..600,000 ms.

When Max Command Age (ms) is set to 0, the time tag is not checked.

The parameter Max Command Age (ms) only takes effect on time tagged command. The commands without time tag are accepted by IEC 104 server no matter how this parameter is configured.

This figure shows the command with Time Tag IEC 104 client:

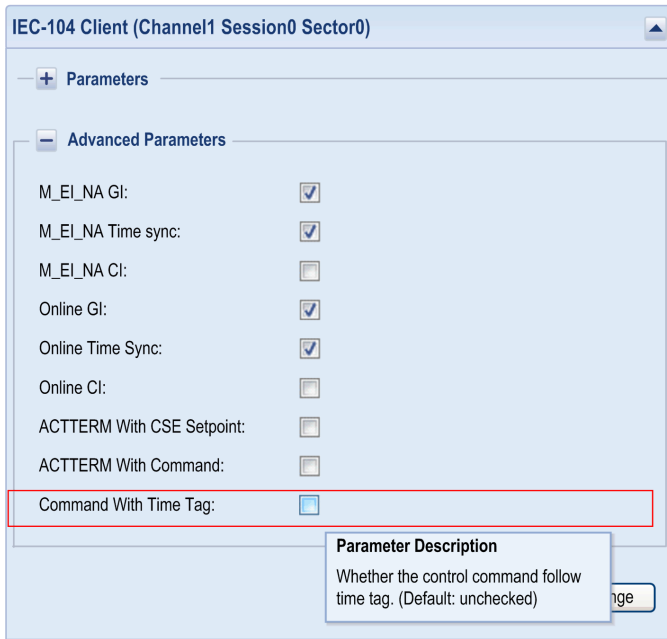

When command with time tag is enabled, the IEC 104 master only supports to send control command with time tag, otherwise, sends control command without time tag.

IEC Data Object Mapping

Introduction

Depending on the data object type and protocol profile selection, different configuration fields are used in the definitions of different data object mapping items.

Exchangeable CPU Data Object

Located and unlocated variables can be exchanged between the CPU and the RTU module after you have defined and managed the memory map of the CPU to exchange data.

The CPU data objects are mapped and only linked for the RTU module purpose.

WARNING

UNINTENDED EQUIPMENT OPERATION

Do not create an instance of redundant data access.

Failure to follow these instructions can result in death, serious injury, or equipment damage.

Data Exchanging Performance

To sustain a high rate of data exchange, we recommend that you define the RTU memory for data objects in a continuous sequence.

NOTE: For each unlocated variable, configured length cannot exceed 1000 bytes.

Module Behavior After Control Expert Application Transfer

NOTE:

After a Control Expert application transfer, the following behavior occurs:

- The RTU protocol service is not restarted (it is only restarted if the RTU module IP address has been modified).
- Depending on the Control Expert application settings, PLC data could be either reset or not.
- Unexpected new events may occur in case of data reset after download.

If you want the system to behave differently, uncheck the `Initialize %MWi on cold start` option in the PLC configuration screen of the Control Expert application.

If you want to reset the RTU protocol service, use the menu `Reset Communication` in the Web site. It is recommended in case of modification of the number of `%M` or `%MW` variables in the Control Expert application.

Dialog Box

This figure shows the dialog box for configuring the data object mapping for an item with the example data type M_SP for IEC 60870-5-101/104 slave/server:

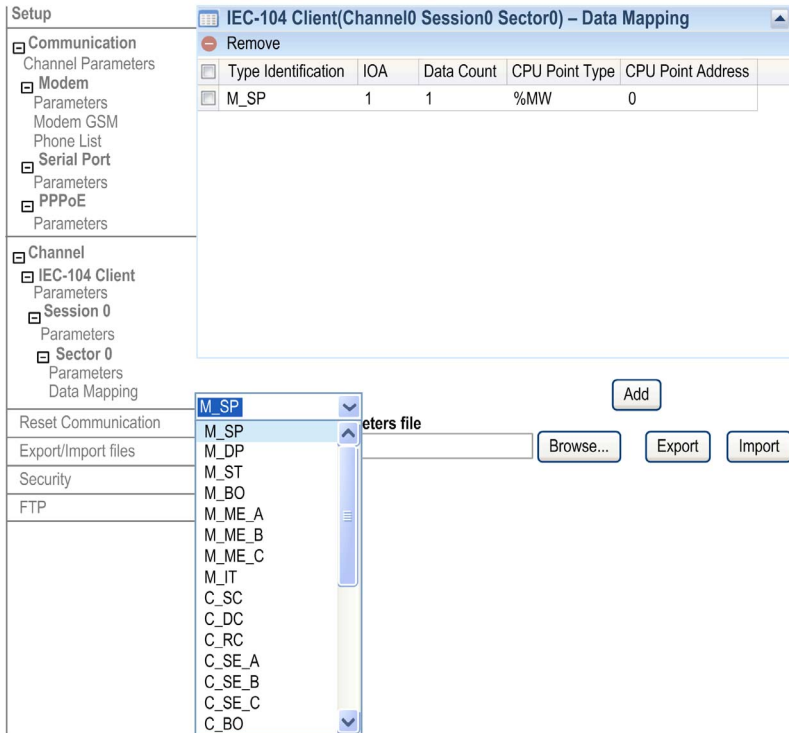

Import/Export

Data object mapping items can be exported (*see page 212*) as a profile in the *.XSY format. Such files can be imported into Control Expert software.

Predefined Command List

The required input fields are requested to define a predefined command item for IEC 60870-5-101/104 (*see page 266*).

IEC Event Queue Setting

Event Queue Setting Page

This figure shows the dialog box for configuring the event queue setting for an item with the example data type M_SP for IEC 60870-5-101/104 slave/server:

The screenshot displays the configuration interface for the IEC Event Queue. The main window is titled "IEC-104 Server(Channel0 Session0 Sector0) - Events". On the left, a navigation tree shows the following structure:

- Setup
 - Communication
 - Channel Parameters
 - Modem
 - Parameters
 - Modem GSM
 - Phone List
 - Serial Port
 - Parameters
 - PPPoE
 - Parameters
 - Channel
 - IEC-104 Server
 - Parameters
 - Session 0
 - Parameters
 - Sector 0
 - Parameters
 - Data Mapping
 - Events

The "Events" section is expanded, showing a table with the following columns: Type Identification, Event Store Mode, Max Event Count, CPU Reg Type, and CPU Reg Address. A dropdown menu is open over the "Type Identification" column, listing the following data types: M_SP (selected), M_DP, M_ST, M_BO, M_ME_A, M_ME_B, M_ME_C, and M_IT. An "Add" button is located to the right of the dropdown menu.

This figure shows the dialog box for configuring the event management:

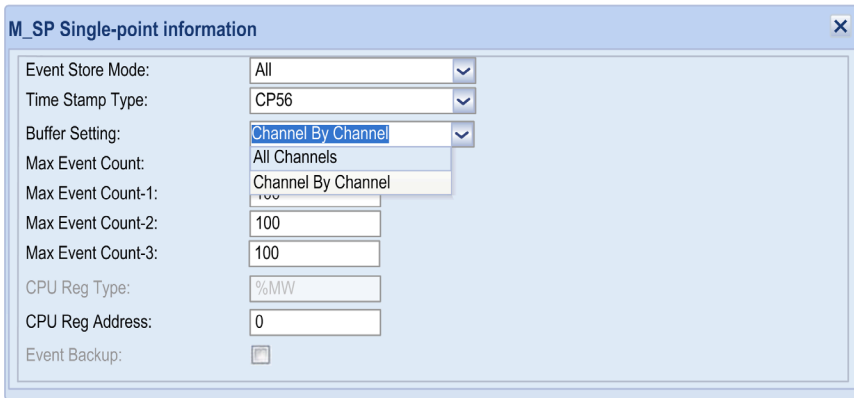

Parameter	Value scope	Default value	Description
Event Store Mode	All/Most Recent	All	stores all events in the queue or only stores most recent events for each object
Time Stamp Type	None/CP24/CP56	CP56	time stamp format for an event
Buffer Setting	Channel by Channel/ All Channels	All Channels	specifies whether the buffer size is configured by channel or not
Max Event Count	1...65535	100	supported event count by channel; in whole, up to 100,000 events are supported
Max Event Count-n	0...65535	1	supported event count by virtual channel #n
CPU Reg Type	%MW	%MW	status register type in CPU
CPU Reg Address	0...32464	0	address of event status register in CPU
Event Backup	check box	unchecked	stores events in case of loss of power

IEC 60870-5-101/104 Master/Client

Predefined Master Commands

The predefined master command of the IEC 60870-5-101/104 master contains these fields:

Command	Status	Meaning
C_SC	Yes	Single point command
C_DC		Double point command
C_RC		Regulating step command
C_SE_A		Set point command, normalized value
C_SE_B		Set point command, scaled value
C_SE_C		Set point command, short floating value
C_BO		32 bits, bit string command
C_IC		Interrogation command
C_CI		Counter interrogation command
C_RD		Read command
C_CS		Clock synchronization command
C_TS		Test command
C_RP		Reset process command

NOTE: When the C_DC address does not receive RTU master command, its initialization value is 0, and it is invalid value in C_DC_NA_1 control command by default. When the master controls this address, the value is 1 or 2 to switch on or off.

Command Implementation Method

Commands can be mapped to the CPU memory, either:

- 32-bit CPU register (command and status) through %MW. Both the command and status are 16 bits.
- 64-bit CPU register (command and status) through %MW. Both the command and status are 32 bits.

Commands are implemented each time when the value in the configured CPU memory changes. This allows the user to control easily the command implementation by changing the value in the CPU memory.

NOTE: In order to support re-send pulse in IEC101 master and IEC104 client, the C_SC_NA and C_DC_NA are triggered to send out on the change of low byte of CPU mapping (%MW) since firmware V1.6 (instead of a change of last bit of CPU mapping (%MW) in previous firmware versions).

Command Status Register

Certain commands have a status register that lets the user know if the command was successfully executed. The status register is a 16-bit word or 32-bit word. For example, if a command is mapped to CPU register `%MW1`, the corresponding status register is automatically mapped to `%MW2`.

NOTE: When a command is mapped to a register and the command has a command status, the status register is automatically mapped to the following register.

If a command has a result, the low byte of the status register increment by 1 to indicate that the status is for the command. The high byte is the status of the command.

NOTE: If the high byte of command status has a result 0, this means that it has completed successfully.

An IEC command status register contains these fields:

Status Value	Description
0	The command has completed successfully.
1	A response was received but the requested command is not yet complete.
2	The command did not transmit as expected.
3	The command has timed out.
4	The command has been canceled.

P/N Control for Control Points (Firmware V1.7 or Later)

P/N bit in the Cause of Transmission field can be either controlled automatically or manually.

The P/N bit can be controlled manually for the following control point types:

- C_SC
- C_DC
- C_SE_A
- C_SE_B
- C_SE_C
- C_BO

To control the P/N bit:

- Configure the **CMD_QUALITY** parameter:
 - **Ctrl Point Type:** Select the control point type.
 - **IOA:** Start IOA that corresponds to the control point type selected.
 - **Point Count:** Control point range from IOA.
 - **CPU Register Address:** `%MW` dedicated to manage the P/N bit.
 - **Variable Name:** Variable associated to `%MW`.

Behavior when the quality of control point is configured (manual control):

- The master sends a command.
- The IEC stack checks for **CMD_QUALITY** settings (%MW associated to quality bit).
 - If the CPU program accepted the command, it puts to 0 the equivalent of P/N bit 7 in %MW. The master receives a valid quality reply.
 - If the CPU program did not accept the command, it puts to 1 the equivalent of P/N bit 7 in %MW. The master receives an invalid quality reply.

Behavior when quality of control point is not configured (automatic control):

- The master sends a command.
- The IEC stack manages P/N bit automatically.

IEC Data Length & Mapping Orientation

IEC 60870-5-101/104

Only data object values are mapped. The quality descriptors for monitoring direction data object and qualifier for control direction data object are not mapped:

Data object type	Data length (bits)	Orientation		Availability	
		Master	Slave/Server	101	104
M_SP	1	Mod -> CPU	CPU -> Mod	x	x
M_DP	2	Mod -> CPU	CPU -> Mod	x	x
M_ST	8	Mod -> CPU	CPU -> Mod	x	x
M_BO	32	Mod -> CPU	CPU -> Mod	x	x
M_ME_A	16	Mod -> CPU	CPU -> Mod	x	x
M_ME_B	16	Mod -> CPU	CPU -> Mod	x	x
M_ME_C	32	Mod -> CPU	CPU -> Mod	x	x
M_IT	32	Mod -> CPU	CPU -> Mod	x	x
C_SC	1	CPU -> Mod	Mod -> CPU	x	x
C_RC	2	CPU -> Mod	Mod -> CPU	x	x
C_SE_A	16	CPU -> Mod	Mod -> CPU	x	x
C_SE_B	16	CPU -> Mod	Mod -> CPU	x	x
C_SE_C	32	CPU -> Mod	Mod -> CPU	x	x
C_BO	32	CPU -> Mod	Mod -> CPU	x	x
C_IC	16	CPU -> Mod	na	x	x
C_CI	16	CPU -> Mod	na	x	x
C_RD	16	CPU -> Mod	na	x	x
C_CS	16	CPU -> Mod	na	x	x
C_TS	16	CPU -> Mod	na	x	x
C_RP	16	CPU -> Mod	na	x	x
P_ME_A	16	CPU -> Mod	Mod -> CPU	x	x
P_ME_B	16	CPU -> Mod	Mod -> CPU	x	x
P_ME_C	32	CPU -> Mod	Mod -> CPU	x	x
P_AC_A	16	CPU -> Mod	Mod -> CPU	x	x

IEC Data Object Type Mapped to Control Expert EDT/DDT

Introduction

The RTU data object is mapped to a Control Expert variable with EDT/DDT while exporting data objects mapping a relationship to an *.XSY file. In addition to the variables you define, the.XSY file contains predefined DDT types for timestamp formats.

IEC 60870-5-101/104

Data object type	Data length (bits)	Control Expert EDT/DDT	Protocols
M_SP	1	WORD	master/slave
M_DP	2	WORD	
M_ST	8	WORD	
M_BO	32	DWORD	
M_ME_A	16	INT	
M_ME_B	16	INT	
M_ME_C	32	REAL	
M_IT	32	DINT	
M_SP + Quality	1	WORD+WORD	
M_DP + Quality	2	WORD+WORD	
M_ST + Quality	8	WORD+WORD	
M_BO + Quality	32	DWORD+DWORD	
M_ME_A + Quality	16	INT+WORD	
M_ME_B + Quality	16	INT+WORD	
M_ME_C + Quality	32	REAL+DWORD	
M_SP + Time	1	WORD+CP56	
M_DP + Time	2	WORD+CP56	
M_ST + Time	8	WORD+CP56	
M_BO + Time	32	DWORD+CP56	
M_ME_A + Time	16	INT+CP56	
M_ME_B + Time	16	INT+CP56	
M_ME_C + Time	32	REAL+CP56	
M_IT + Time	32	DINT+CP56	
M_SP + Quality + Time	1	WORD+WORD	
M_DP + Quality + Time	2	WORD+WORD+CP56	
M_ST + Quality + Time	8	WORD+WORD+CP56	
M_BO + Quality + Time	32	DWORD+DWORD+CP56	
M_ME_A + Quality + Time	16	INT+WORD+CP56	
M_ME_B + Quality + Time	16	INT+WORD+CP56	
M_ME_C + Quality + Time	32	REAL+DWORD+CP56	
M_IT + Quality + Time	32	DINT+DWORD+CP56	

Data object type	Data length (bits)	Control Expert EDT/DDT	Protocols
C_SC	1	WORD	slave
C_DC	2	WORD	
C_RC	8	WORD	
C_SE_A	16	INT	
C_SE_B	16	INT	
C_SE_C	32	REAL	
C_BO	32	DWORD	
CUSTOM_CMD + Status ⁽¹⁾	16	WORD+WORD	master
C_SC + Status	1	WORD+WORD	
C_DC + Status	2	WORD+WORD	
C_RC + Status	8	WORD+WORD	
C_SE_A + Status	16	INT+WORD	
C_SE_B + Status	16	INT+WORD	
C_SE_C + Status	32	REAL+DWORD	
C_BO + Status	32	DWORD+DWORD	
C_IC + Status	16	WORD+WORD	
C_CI + Status	16	WORD+WORD	
C_RD + Status	16	WORD+WORD	
C_CS + Status	16	WORD+WORD	
C_TS + Status	16	WORD+WORD	
C_RP + Status	16	WORD+WORD	
P_ME_A + Status	16	WORD+WORD	
P_ME_B + Status	16	WORD+WORD	
P_ME_C + Status	32	REAL+DWORD	
P_AC_A + Status	16	WORD+WORD	
1: This feature is available with firmware V1.7 or later.			

NOTE: The DDT format CP56 is derived from IEC60870-5-4.

Section 13.3

Web Site Configuration DNP3

What Is in This Section?

This section contains the following topics:

Topic	Page
DNP3 Master/DNP3 NET Client RTU Protocol Parameters	274
DNP3 Slave/Server RTU Protocol Parameters	280
DNP3 Channel Configuration Over UDP	288
DNP3 Data Object Mapping Page and Table	292
DNP3 Data Object Mapping	308
DNP3 Event Queue Setting	313
DNP3 Master/ DNP3 Net Client	315
DNP3 Data Length & Mapping Orientation	317
DNP3 Data Object Type Mapped to Control Expert EDT/DDT	318

DNP3 Master/DNP3 NET Client RTU Protocol Parameters

Introduction

Add a DNP3 NET master (client) in the communication setup by selecting DNP3 as Protocol, Ethernet as Network Type and Master as Mode.

Channel Parameters

Click **Setup** → **Channel** → **Parameters**:

The screenshot shows a web interface for configuring Channel0. It features a 'Parameters' section with a 'Session Count' input field containing the value '5'. Below this is an 'Advanced Parameters' section. A 'Change' button is located at the bottom right of the configuration area.

Parameter	Value scope	Default value	Description
Session Count	1...32	1	indicates the maximum session number on this channel

Configure the module advanced parameters:

DNP3 NET Client (Channel0)

+ Parameters

- Advanced Parameters

Rx Frame Size:	<input type="text" value="292"/>
Tx Frame Size:	<input type="text" value="292"/>
Rx Frame Timeout(ms):	<input type="text" value="15000"/>
Confirm Mode:	<input type="text" value="NEVER"/> ▾
Confirm Timeout(ms):	<input type="text" value="2000"/>
Max Retries:	<input type="text" value="3"/>
Offline Poll Period(ms):	<input type="text" value="10000"/>
First Char Wait(ms):	<input type="text" value="0"/>
Rx Buffer Size:	<input type="text" value="256"/>
Rx Fragment Size:	<input type="text" value="2048"/>
Tx Fragment Size:	<input type="text" value="2048"/>
Max Queue Size:	<input type="text" value="0"/>
Channel Response Timeout(ms):	<input type="text" value="10000"/>
Analog Mode:	<input type="text" value="All 32-bits"/> ▾

Parameter	Value scope	Default value	Description
Rx Frame Size	0...292	292	indicates the maximum received message frame size in the data link layer (bytes)
Tx Frame Size	0...292	292	indicates the maximum Transmit message frame size in the data link layer (bytes)
Rx Frame Timeout (ms)	0...4294967295	15000	indicates time-out while waiting for a complete frame after receiving frame synchronization
Confirm Mode	NEVER SOMETIMES ALWAYS	NEVER	specifies when to request for link layer confirmation
Confirm Timeout (ms)	0...4294967295	2000	indicates the maximum time to wait for link level confirmation if requested
Max Retries	0...255	3	indicates the retry count of link layer confirmation time-out
1: This feature is available with firmware V1.7 or later.			

Parameter	Value scope	Default value	Description
Offline Poll Period (ms)	0...4294967295	10000	specifies the period to re-establish communication for an offline session
First Char Wait (ms)	0...65535	0	indicates the minimum time between reception and transmission
Rx Buffer Size	0...65535	256	indicates the received buffer size of the serial port
Rx Fragment Size	0...256	2048	indicates the maximum message frame length in the data link layer (bytes)
Tx Fragment Size	0...20486	2048	indicates the maximum message frame length in the data link layer (bytes)
Max Queue Size	0...2048	0	indicates the maximum request message number with specific Application Specific Data Unit type in the transmission queue
Channel Response Timeout (ms)	0...4294967295	10000	specifies how often to reestablish communication for an offline session
Analog Mode ⁽¹⁾	All 32-bits Mixed Mode	All 32-bits	specifies dynamic memory allocation for analog points. Behavior: All 32-bits: 32 bits are always allocated, no matter if it is for 16 bits or 32 bits analog input/output. Mixed Mode: Memory allocation depends on the analog input/output variation (16 bits / 32 bits / float).
1: This feature is available with firmware V1.7 or later.			

Session Parameters

Click **Setup** → **Channel** → **Session** → **Parameters** :

DNP3 NET Client (Channel0 Session0)

Parameters

IP Address: 255.255.255.255

Dest Port: 20000

Local Address: 3

Slave Address: 4

Default Response Timeout(ms): 30000

Advanced Parameters

Change

Parameter	Value scope	Default value	Description
IP Address	0...255.255.255.255	192.168.0.1	indicates the source address for this session
Dest Port	1...65534	20000	indicates the destination address for this session. IP Address of remote device (multiple address separate by semicolon). If configured as client, only one IP address should be given here.
Local Address	1...65520	3	indicates the source address for this session
Slave Address	1...65520 and FFFC hex	4	indicates the slave address for this session
Default Response Timeout (ms)	0...4294967295	30000	indicates the absolute maximum amount of time this device waits for the final response to a request. This time starts as soon as the request is put into the transmit queue.

Configure the module's advanced parameters:

The screenshot shows a configuration window titled "DNP3 NET Client(Channel1 Session0)". Under the "Parameters" section, the "Advanced Parameters" sub-section is expanded. It contains the following settings:

- Link Status Period (ms): 2500
- Auto Integrity Local:
- Auto Integrity Timeout:
- Auto Event Poll:
- Auto Delay Measure:
- Auto Time Sync: None
- Auto Unsolicited: None
- Auto Enable Unsol Class1:
- Auto Enable Unsol Class2:
- Auto Enable Unsol Class3:
- Read Timeout Allowed: 0

A "Change" button is located at the bottom right of the configuration area.

Parameter	Value scope	Default value	Description
Link Status Period (ms)	0..4294967295	2500	indicates the duration for sending link status requests, if no DNP3 frames are received on this session
Auto Integrity Local	check box	checked	sends integrity data poll after the local IIN bit is set and cleared
Auto Integrity Timeout	check box	checked	sends integrity data poll on time-out
Auto Event Poll	check box	unchecked	sends event data poll when class 1, 2, or 3 IIN bit is set
Auto Delay Measure	check box	unchecked	indicates the usage of delay measurement in time synchronization
Auto Time Sync	None/Serial/ LAN	None	performs time synchronization on required time: None: no time sync Serial: sync through serial link LAN: sync through LAN

Parameter	Value scope	Default value	Description
Auto Unsolicited	None/Enable/Disable	None	automatically send unsolicited command upon remote device startup: None: do not send unsolicited command Enable: send enable command Disable: send disable command
Auto Enable Unsol Class1	check box	checked	indicates which event classes is enabled for unsolicited reporting
Auto Enable Unsol Class2	check box	checked	indicates which event classes is enabled for unsolicited reporting
Auto Enable Unsol Class3	check box	checked	indicates which event classes is enabled for unsolicited reporting
Read Timeout Allowed	0...255	0	specifies number of times a read request is allowed to time-out before the session is considered offline

DNP3 Slave/Server RTU Protocol Parameters

Introduction

Select DNP3 as Protocol, an Ethernet network as Network Type and Slave (server) as Mode.

Channel Parameters

Click **Setup** → **Channel** → **DNP3 NET Server** → **Parameters**:

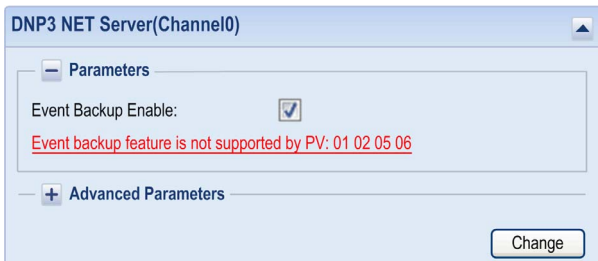

NOTE: There is no basic channel parameter to configure in the DNP3 slave/server case.

Parameter	Value scope	Default value	Description
Event Backup Enable	check box	unchecked	Refer to the DNP3 Event Queue Setting (<i>see page 313</i>) topic to specify which events to configure as backup or turned off when a power loss occurs.
Event Restore Mode	Main Channel/All Channels	Main Channel	indicates which channel the events restore

Configure the module advanced parameters:

DNP3 NET Server(Channel0)

+ Parameters

- Advanced Parameters

Rx Frame Size:

Tx Frame Size:

Rx Frame Timeout (ms):

Confirm Mode: ▼

Confirm Timeout (ms):

Max Retries:

Offline Poll Period (ms):

First Char Wait (ms):

Rx Buffer Size:

Rx Fragment Size:

Tx Fragment Size:

Analog Mode: ▼

Parameter	Value scope	Default value	Description
Rx Frame Size	0...292	292	indicates the maximum received message frame size in the data link layer (bytes)
Tx Frame Size	0...292	292	indicates the maximum Transmit message frame size in the data link layer (bytes)
Rx Frame Timeout (ms)	0..4294967295	15000	indicates the time-out while waiting for a complete frame after receiving frame synchronization
Confirm Mode	NEVER SOMETIMES ALWAYS	NEVER	specifies when a link layer confirmation can be requested
Confirm Timeout (ms)	0..4294967295	2000	indicates the maximum time to wait for link level confirmation if requested
Max Retries	0...255	3	indicates the retry count of link layer confirmation time-outs
Offline Poll Period (ms)	0..4294967295	10000	specifies the duration to re-establish communication for an offline session
1: This feature is available with firmware V1.7 or later.			

Parameter	Value scope	Default value	Description
First Char Wait (ms)	0...65535	0	indicates the minimum time between reception and transmission
Rx Buffer Size	0...256	256	indicates the received buffer size of serial port (bytes)
Rx Fragment Size	0...2048	2048	indicates the maximum message frame length in the data link layer (bytes)
Tx Fragment Size	0...2048	2048	indicates the maximum message frame length in the data link layer (bytes)
Analog Mode ⁽¹⁾	All 32-bits Mixed Mode	All 32-bits	specifies dynamic memory allocation for analog points. Behavior: All 32-bits: 32 bits are always allocated, no matter if it is for 16 bits or 32 bits analog input/output. Mixed Mode: Memory allocation depends on the analog input/output size.
1: This feature is available with firmware V1.7 or later.			

Session Parameters

Click **Setup** → **Channel** → **DNP3 NET Server** → **Session** → **Parameters**:

Parameter	Value scope	Default value	Description
Local Address	1...65520	4	indicates the source address for this session
Master Address	1...65520	3	indicates the destination address for this session

Configure the module with advanced parameters:

Advanced Parameters

Link Status Period (ms):	<input type="text" value="2500"/>
Validate Source Address:	<input type="checkbox"/>
Enable Self Address:	<input type="checkbox"/>
Multi Frag Resp Allowed:	<input checked="" type="checkbox"/>
Multi Frag Confirm:	<input checked="" type="checkbox"/>
Respond Need Time:	<input type="checkbox"/>
Clock Valid Period (ms):	<input type="text" value="1800000"/>
Application Confirm Timeout (ms):	<input type="text" value="10000"/>
Select Timeout (ms):	<input type="text" value="5000"/>
Warm Restart Delay (ms):	<input type="text" value="2000"/>
Cold Restart Delay (ms):	<input type="text" value="5000"/>
Allow Multi CROB Requests:	<input checked="" type="checkbox"/>
Max Control Requests:	<input type="text" value="10"/>
Unsol Allowed:	<input checked="" type="checkbox"/>
Send Unsol When Online:	<input type="checkbox"/>
Unsol Class 1 Max Events:	<input type="text" value="5"/>
Unsol Class 2 Max Events:	<input type="text" value="5"/>
Unsol Class 3 Max Events:	<input type="text" value="5"/>
Unsol Class 1 Max Delay (ms):	<input type="text" value="5000"/>
Unsol Class 2 Max Delay (ms):	<input type="text" value="5000"/>
Unsol Class 3 Max Delay (ms):	<input type="text" value="5000"/>
Unsol Max Retries:	<input type="text" value="3"/>
Unsol Retry Delay(ms):	<input type="text" value="5000"/>
Unsol Offline Retry Delay (ms):	<input type="text" value="30000"/>
Delete Oldest Event:	<input type="checkbox"/>
Pulse Duration:	<input type="text" value="1000"/>
Counts to Class0 Poll:	<input type="text" value="Count Value"/> <input type="button" value="v"/>
Routing Offline:	<input type="text" value="Valid Quality"/> <input type="button" value="v"/>
Data Synch Mode:	<input type="text" value="Cyclic Synch"/> <input type="button" value="v"/>
SBO Mode:	<input type="text" value="Interference Mode"/> <input type="button" value="v"/>
Trip-Close Mode:	<input type="text" value="Even Mode"/> <input type="button" value="v"/>
PLC State:	<input type="text" value="No Impact Quality"/> <input type="button" value="v"/>

Parameter	Value scope	Default value	Description
Link Status Period (ms)	0...4294967295	2500	indicates the period to send link status requests if no DNP3 frames are received on this session
Validate Source Address	check box	unchecked	specifies if the source address is validated in received frames
Enable Self Address	check box	unchecked	responds with its own address so that the master can automatically discover the slave address
Multi Frag Resp Allowed	check box	checked	specifies if the application is allowed to send multi-fragment responses
Multi Frag Confirm	check box	checked	specifies if the application layer confirmations are requested for no final fragments of a multi-fragment response
Respond Need Time	check box	unchecked	specifies if this device sets the need time IIN bit in response to this session at startup and after the clock valid period has elapsed
Clock Valid Period (ms)	0...4294967295	1800000	specifies the period for which the clock remains valid after receiving time synchronization
Application Confirm Timeout (ms)	0...4294967295	10000	specifies the period for which the slave DNP3 device waits for the application layer confirmation from the master
Select Timeout (ms)	0...4294967295	5000	specifies the maximum amount of time that a selection remains valid before the corresponding operation is received
Warm Restart Delay (ms)	0...65535	2000	indicates that the master should wait after receiving a response to a warm restart request
Cold Restart Delay (ms)	0...65535	5000	indicates that the master should wait after receiving a response to a cold restart request
Allow Multi CROB Requests	check box	checked	determines if the objects of the Multiple Control Relay Output block are allowed in a single request
Max Control Requests	0...10	10	determines if the maximum number of controls are allowed in a single request
Unsol Allowed	check box	checked	determines if the unsolicited responses are allowed
<p>1: This feature is available with firmware V1.7 or later.</p> <p>NOTE: Only %MW and %M output points are supported in the Synch On Demand mode. To make local change operational by CPU application on digital or analog output, select Synch On Demand mode.</p>			

Parameter	Value scope	Default value	Description
Send Unsol When Online	check box	unchecked	determines if the unsolicited null responses are transmitted when the session comes online
Unsol Class 1	check box	unchecked	specifies the initial/new state of the unsolicited event mask (only RTU V1.0)
Unsol Class 2	check box	unchecked	specifies the initial/new state of the unsolicited event mask (only RTU V1.0)
Unsol Class 3	check box	unchecked	specifies the initial/new state of the unsolicited event mask (only RTU V1.0)
Unsol Class 1 Max Events	0..255	5	If unsolicited responses are enabled, <code>UnsolClassXMaxEvents</code> specifies the maximum number of events in the corresponding class to be allowed before an unsolicited response is generated.
Unsol Class 2 Max Events	0..255	5	If unsolicited responses are enabled, <code>UnsolClassXMaxEvents</code> specifies the maximum number of events in the corresponding class to be allowed before an unsolicited response is generated.
Unsol Class 3 Max Events	0..255	5	If unsolicited responses are enabled, <code>UnsolClassXMaxEvents</code> specifies the maximum number of events in the corresponding class to be allowed before an unsolicited response is generated.
Unsol Class 1 Max Delay (ms)	0..4294967295	5000	specifies the maximum amount of time after an event in the corresponding class is received before an unsolicited response is generated
Unsol Class 2 Max Delay (ms)	0..4294967295	5000	specifies the maximum amount of time after an event in the corresponding class is received before an unsolicited response is generated
Unsol Class 3 Max Delay (ms)	0..4294967295	5000	specifies the maximum amount of time after an event in the corresponding class is received before an unsolicited response is generated
Unsol Max Retries	0..65535	3	specifies the maximum number of unsolicited retries before changing to the offline retry period
Unsol Retry Delay	0..4294967295	5000	specifies the time to delay after an unsolicited confirmation time-out before retrying the unsolicited response
<p>1: This feature is available with firmware V1.7 or later.</p> <p>NOTE: Only %MW and %M output points are supported in the Synch On Demand mode. To make local change operational by CPU application on digital or analog output, select Synch On Demand mode.</p>			

Parameter	Value scope	Default value	Description
Unsol Offline Retry Delay (ms)	0...4294967295	30000	specifies the time to delay after an unsolicited time-out before retrying the unsolicited response after <code>UnsolMaxRetries</code> are attempted
Delete Oldest Event	check box	unchecked	specifies if the oldest event is removed from the event queue when buffer is full and a new event comes. Checked: Remove the oldest event. Unchecked: Ignore the new event.
Pulse Duration	0...4294967295	1000	indicates the width of the pulse in milliseconds
Counts to Class0Poll	Count Value Frozen Value	Count Value	specifies whether static counter data (Count Value) or static counter frozen data (Frozen Value) is returned in polls of class0 data
Routing Offline ⁽¹⁾	Valid Quality Invalid Quality	Valid Quality	specifies if routing point quality depends on connection state with subslave or subserver. Behavior: Valid Quality: Routing points quality does not change when connection is lost. Invalid Quality: Routing points quality is marked as invalid when connection is lost.
Data Synch Mode	Cyclic Synch Synch On Demand	Cyclic Synch	specifies how the data are synchronized: either cyclically or when the slave station receives a request from the master (see Note). It is used only by analog outputs.
SBO Mode ⁽¹⁾	Interference Mode Noninterference Mode	Interference Mode	specifies the commands allowed to cancel a Select command in a sequence Behavior: Interference Mode: Select can be canceled by any command except Operate command. Noninterference Mode: Select can be canceled by any command.
Trip-Close Mode ⁽¹⁾	Even Mode Consecutive Mode	Even Mode	specifies if trip_close DNP3 points are consecutive or not
<p>1: This feature is available with firmware V1.7 or later.</p> <p>NOTE: Only %MW and %M output points are supported in the Synch On Demand mode. To make local change operational by CPU application on digital or analog output, select Synch On Demand mode.</p>			

Parameter	Value scope	Default value	Description
PLC State ⁽¹⁾	No Impact Quality Impact Quality	No Impact Quality	for non-routing points, specifies if the PLC state modifies or not the quality bit when quality is required by the master. Behavior: No Impact Quality: PLC state has no effect on the quality bit. Impact Quality: PLC state has an effect on the quality bit. A PLC in <code>STOP</code> state or a PLC missing generates an invalid quality bit. A PLC in <code>RUN</code> state generates a valid quality bit.
<p>1: This feature is available with firmware V1.7 or later.</p> <p>NOTE: Only %MW and %M output points are supported in the Synch On Demand mode. To make local change operational by CPU application on digital or analog output, select Synch On Demand mode.</p>			

Unsolicited Response Parameters

`Unsol Class x Max Events` and `Unsol Class x Max Delay` parameters are used as triggers to initiate unsolicited messages.

Each event class (1...3) has its own parameters. Once the trigger conditions match for at least one event class, all event classes enabled to initiate unsolicited messages send the messages (whether they met the trigger conditions or not).

Example:

- Settings:
 - Unsolicited responses allowed for Class 1 + Class 2
 - Unsolicited responses not allowed for Class 3
- Trigger condition (max events or max delay reached):
 - Class 1 does not meet trigger condition.
 - Class 2 meets trigger condition.
 - Class 3 is not evaluated (unsolicited response not allowed).
- Result:
 - Class 1 + Class 2 send the events stored.
 - Class 3 does not send events.

DNP3 Channel Configuration Over UDP

Communication Setup

Select which communication needs to be configured via the Web site before configuring the ports of the BMXNOR0200H module. The BMXNOR0200H module supports UDP in two ways: UDP-IP and TCP-UDP. When it is TCP-UDP, the BMXNOR0200H module supports the sending/receiving of broadcast requests.

Set DNP3 NET client/DNP3 NET server over UDP:

The screenshot shows a configuration window titled "Channel0" with the following fields and values:

- Channel ID: 0
- Protocol: DNP3
- Network Type: TCP-IP
- Mode: TCP-IP
- IP Address: UDP-IP (selected in a dropdown menu)
- Local Port: TCP-UDP
- Connection Count: 1
- Status Reg Type: %MW
- Status Reg Start Address: 0

Configuration

For UDP-IP and TCP-UDP, it is necessary to set special ports and IP address according to DNP3 specifications.

UDP-IP			
Client		Server	
Name	Description	Name	Description
Destination port	Destination port for UDP	Local port	Local port for UDP; it must be unique.
Local port	Local port for UDP-IP; it must be unique in current channel. Exception: 0 means that the local port is generated automatically by the system	Destination port	Destination port for UDP. 0 is allowed, which means that the server uses the port from which the master sent the request.
		Unsol destination port	Port that the server uses to send initial unsolicited responses in UDP-IP

TCP-UDP			
Client		Server	
Name	Description	Name	Description
TCP destination port	Destination port for TCP	TCP local port	Local port for TCP
UDP broadcast port	Port that sends broadcasts in TCP-UDP	UDP local port	Port that receives broadcasts (available for TCP-UDP)

Only one IP is allowed.

IP and port configuration of DNP3 Net client UDP-IP:

DNP3 NET Client(Channel0 Session0)

Parameters

IP Address: 255.255.255.255

Dest Port: 20000

Local Port: 20000

Local Address: 3

Slave Address: 4

Default Response Timeout(ms): 30000

Advanced Parameters

Change

IP and port configuration of DNP3 Net client TCP-UDP:

DNP3 NET Client(Channel1 Session0)

Parameters

IP Address: 255.255.255.255

TCP Dest Port: 20000

UDP Broadcast Port: 20000

Broadcast Address: 0.0.0.0

Local Address: 3

Slave Address: 4

Default Response Timeout(ms): 30000

Advanced Parameters

Change

When the BMXNOR0200H module works as client in TCP-UDP, it can send command requests in broadcasts. Beside broadcast address configuration, it is necessary to specify the destination address. Here are the options of broadcast confirmation, which are used to specify the destination address for sending broadcast requests.

Options	Definition address	Special use
Optional	FFFF hex	All-call, application layer confirmation to clear IIN1.0 is optional.
Mandatory	FFFE hex	All-call, application layer confirmation to clear IIN1.0 is mandatory.
Never	FFFD hex	All-call, application layer confirmation must not be required to clear IIN1.0.

Destination address configuration of broadcasts:

The screenshot shows the configuration window for 'DNP3 NET Client(Channel1 Session0)'. Under the 'Advanced Parameters' section, the 'Broadcast Confirmation' dropdown menu is open, showing three options: NEVER, Mandatory, and Optional. The 'Optional' option is currently selected. A red box highlights the dropdown menu and the 'Change' button to its right.

In TCP-UDP, it depends on whether this command is broadcast or not to the client. So it is necessary to enable it explicitly in data mapping setting:

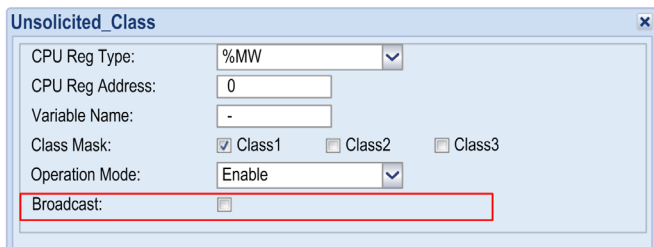

NOTE:

- Not all commands are supported in broadcast; BMXNOR0200H module client supports:
 - Restart
 - Time_Sync
 - Unsolicited_Class
 - Freeze_Counter
 - Binary_Output
 - Analog_Output
- Freeze_Counter, Binary_Output, and Analog_Output support broadcast only when operation mode (function code) is without acknowledgment.
- Broadcasting is only supported in TCP-UDP.
- The BMXNOR0200H module server receives and accepts the broadcast request, but does not respond to any broadcast requests.

DNP3 Data Object Mapping Page and Table

Data Object Mapping Page

This figure shows the dialog box for configuring the data object mapping for an item with the example data type **Binary_Input** for DNP3 slave/server:

The screenshot displays the 'DNP3 NET Server(Channel0 Session0) - Data Mapping' dialog box. On the left is a tree view showing the configuration path: Setup > Channel > DNP3 NET Server > Session 0 > Data Mapping. The main area contains a table with the following data:

Type Identification	Point Number	Data Count	CPU Point Type	CPU Point Address
Binary_Input	0	1	%MW	0

Below the table, there is a dropdown menu currently showing 'Binary_Input'. Other options in the dropdown include Double_Input, Binary_Output, Binary_Counter, Analog_Input, Analog_Output, Analog_Input_Deadband, Binary_Output_Flags, and Analog_Output_Flags. To the right of the dropdown are buttons for 'Add', 'Browse...', 'Export', and 'Import'. A 'Parameters file' label is also visible near the 'Browse...' button.

This figure shows the dialog box for configuring the `Binary_Input` data object mapping with DNP3 NET Server:

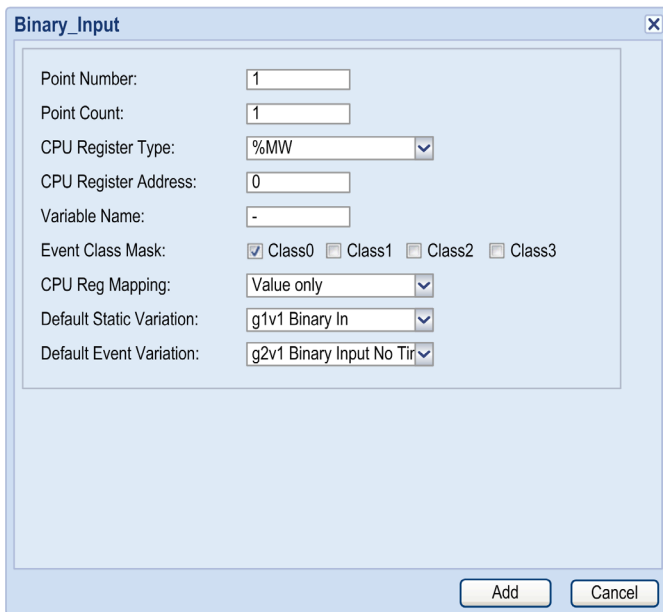

The image shows a dialog box titled "Binary_Input" with a close button (X) in the top right corner. The dialog contains the following configuration fields:

- Point Number:
- Point Count:
- CPU Register Type: (dropdown menu)
- CPU Register Address:
- Variable Name:
- Event Class Mask: Class0 Class1 Class2 Class3
- CPU Reg Mapping: (dropdown menu)
- Default Static Variation: (dropdown menu)
- Default Event Variation: (dropdown menu)

At the bottom right of the dialog, there are two buttons: "Add" and "Cancel".

This figure shows the dialog box for configuring the `Binary_Input` data object mapping with DNP3 NET Client:

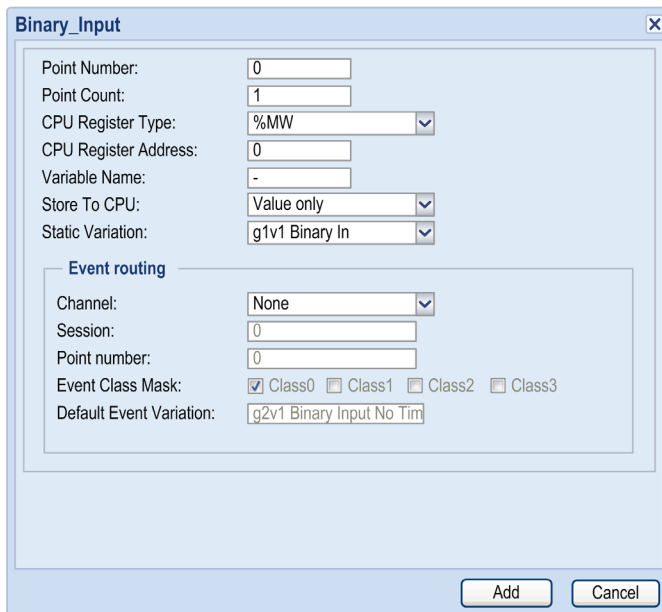

Mapping Table

Depending on the data object type and the selected protocol profile, different configuration fields are required to define a data object mapping item. This table describes the parameters:

Title	Value scope	Default value	Description
Point Number	0...16777215	0	indicates the start number of the point ⁽¹⁾ .
Point Count	1...65535	1	indicates the number of points.
CPU Register Type	%M/%MW/%S/ %SW/ Unlocated	%MW	indicates the register type in CPU to map points ⁽²⁾ .
CPU Register Address	0...30000	0	indicates start address of the register in CPU. This field only taken into account for located variables. With %S, the range is from 0 to 127.
Variable Name	-	-	indicates the variable name of the located or unlocated register.
<p>1: The DNP3 point number must start from 0 and be contiguous in slave/server mode. If this is not applied, the nonconsecutive points cannot work normally.</p> <p>2: DNP3 Server: %S applies only to binary inputs and %SW only to analog inputs, 32-bit analog inputs; the CPU mapping does not apply array due to the limits of Control Expert.</p>			

Title	Value scope	Default value	Description
Event Class Mask (0/1/2/3/Unsolicited)	check box	0	defines the event class of points. <i>Unsolicited</i> is not allowed with class 0 only. In client, <i>Channel</i> must be at 0.
Store To CPU (Client) OR CPU Reg Mapping (Server)	Value only Value with time Value with flag Value with flag and time	Value only	Event time stamp source: Value only: module time Value with time: time in CPU registers Value with flag: flag info on the point is taken from CPU registers Value with flag and time: flag and time are taken from CPU registers
(Default) Static Variation	g1v1 Binary In/ g1v2 Binary In Flag	g1v1 Binary In	indicates the default static variation for data point
Event routing (Client only)			
Channel	None/0	None	indicates the channel number to route
Session	0	0	indicates the session number to route (<i>Channel</i> at 0)
Point number	0...16777215	0	indicates the point number to route (<i>Channel</i> at 0)
Default Event Variation	g2v1 Binary Input No Time g2v1 Binary Input With Time g2v1 Binary Input Relative Time	g2v1 Binary Input No Time	indicates the default event variation for data point
<p>1: The DNP3 point number must start from 0 and be contiguous in slave/server mode. If this is not applied, the nonconsecutive points cannot work normally.</p> <p>2: DNP3 Server: %S applies only to binary inputs and %SW only to analog inputs, 32-bit analog inputs; the CPU mapping does not apply array due to the limits of Control Expert.</p>			

Configuring Unsolicited Response

The RTU module supports unsolicited messages to be sent out immediately once events are recorded.

Configuration of Unsolicited:

Binary_Input [X]

Point Number: 0

Point Count: 1

CPU Register Type: %MW

CPU Register Address: 0

Variable Name: -

Event Class Mask: Class0 Class1 Class2 Class3 Unsolicited

CPU Reg Mapping: Value only

Default Static Variation: g1v1 Binary In

Default Event Variation: g1v1 Binary Input No Tin

To check the Unsolicited parameter, you must have another Even Class Mask parameter (other than class 0) selected. The Unsolicited parameter can be configured for Binary Input, Double Input, Double Input, Binary Count and Analog Input in the Server.

Unsolicited with routing points (Client):

Binary_Input [X]

Point Number: 0

Point Count: 5

CPU Register Type: %MW

CPU Register Address: 10000

Variable Name: rout_bin_class1

Store To CPU: Value only

Static Variation: g1v1 Binary In

Event routing

Channel: 1

Session: 0

Point number: 20

Event Class Mask: Class0 Class1 Class2 Class3 Unsolicited

Default Event Variation: g2v2 Binary Input with T

In events generation, `Unsolicitedmessages` are sent when one of the following conditions are met:

1. `Unsolicited` messages are enabled and the number of events in the buffer exceeds the minimum amount.
2. `Unsolicited` messages are enabled and the delay (timeout) to report expires.
3. Events are generated for the point that is set for immediate `Unsolicited` message reporting, regardless if the two conditions above are met or not.
4. Events are generated for a point that is set for immediate `Unsolicited` message reporting, then all events in the buffer are immediately reported.

Quality Bit/Flag Mapping

The configuration applies quality bit/flag mapping to the CPU register for monitoring datapoints for the DNP3 master/DNP3 slave.

NOTE: Use this feature for **Binary_Input**, **Double_Input**, **Binary_Counter**, **Analog_Input**, **Binary_Output**, and **Analog_Output**.

This figure shows the flag configuration:

The screenshot shows a configuration window titled "Binary_Input" with the following fields and options:

- Point Number: 10
- Point Count: 1
- CPU Register Type: %MW
- CPU Register Address: 0
- Variable Name: -
- Event Class Mask: Class0 Class1 Class2 Class3
- CPU Reg Mapping: Value only (dropdown menu is open showing options: Value only, Value with time, Value with flag, Value with flag and time)
- Default Static Variation: (empty)
- Default Event Variation: (empty)

The configuration reuses **Timestamp Source** in the slave and **Store To CPU** in the master, and expands two choices based on RTU V1.0. The DNP3 master and DNP3 slave have similar configuration pages for quality bits and flags.

Behavior:

- Input and output point types apply this feature.
- If the end user configures the flag in the CPU register in the slave, the module no longer manages the flags internally. The RTU module generates events following in the CPU register, otherwise, the RTU module generates them automatically.
- In the DNP3 Net server/DNP3 slave, the change of flags in CPU can trigger the generation of events just like value changes.
- The length of the flag is 1 byte no matter how many bytes are mapped in the CPU register, the least byte is valid. Refer to memory allocation.

This table shows the flag definition:

Point	Flag definition	Options	Comments
Binary Input Flags	on-line	bit 0: 0 (off-line)/ 1 (on-line)	–
	restart	bit 1: 0 (normal/ 1 (restart)	
	communication lost	bit 2: 0 (normal/ 1 (lost)	
	remote forced data	bit 3: 0 (normal)/ 1 (forced)	
	local forced data	bit 4: 0 (normal)/ 1 (forced)	
	chatter filtered	bit 5: 0 (normal)/ 1 (filter on)	Events are generated when the CHATTER_FILTER flag is set and cleared, but not when CHATTER_FILTER is set.
	reserved	bit 6: 0	Not used
	state	bit 7: 0 /1	
Binary Output Status Flags	on-line	bit 0: 0 (off-line)/1 (on-line)	–
	restart	bit 1: 0 (normal/1 (restart)	
	communication lost	bit 2: 0 (normal/1 (lost)	
	remote forced data	bit 3: 0 (normal)/1 (forced)	
	local forced data	bit 4: 0 (normal)/1 (forced)	
	chatter filtered	bit 5: 0	Not used
	reserved	bit 6: 0	–
	state	bit 7: 0 /1	

Point	Flag definition	Options	Comments
Double Input Flags	on-line	bit 0: 0 (off-line)/1 (on-line)	–
	restart	bit 1: 0 (normal)/1 (restart)	
	communication lost	bit 2: 0 (normal)/1 (lost)	
	remote forced data	bit 3: 0 (normal)/1 (forced)	
	local forced data	bit 4: 0 (normal)/1 (forced)	
	chatter filtered	bit 5: 0 (normal)/1 (filter on)	Events are generated when <code>CHATTER_FILTER</code> flag is set and cleared, but not when it is set.
	state	bit 6: 0/1	Not used
	state	bit 7: 0/1	
Analog Input Flags	on-line	bit 0: 0 (off-line)/1 (on-line)	–
	restart	bit 1: 0 (normal)/1 (restart)	
	communication lost	bit 2: 0 (normal)/1 (lost)	
	remote forced data	bit 3: 0 (normal)/1 (forced)	
	local forced data	bit 4: 0 (normal)/1 (forced)	
	over range	bit 5: 0 (normal)/1 (over range)	
	reference error	bit 6: 0 (normal)/1 (error)	
	reserved	bit 7: 0	Not used
Analog Output Status Flags	on-line	bit 0: 0 (off-line)/1 (on-line)	–
	restart	bit 1: 0 (normal)/1 (restart)	
	communication lost	bit 2: 0 (normal)/1 (lost)	
	remote forced data	bit 3: 0 (normal)/1 (forced)	
	local forced data	bit 4: 0 (normal)/1 (forced)	
	over range	bit 5: 0 (normal)/1 (over range)	
	reference error	bit 6: 0 (normal)/1 (error)	
	reserved	bit 7: 0	Not used

Point	Flag definition	Options	Comments
Counter Flags	on-line	bit 0: 0 (off-line)/1 (on-line)	-
	restart	bit 1: 0 (normal)/1 (restart)	
	communication lost	bit 2: 0 (normal)/1 (lost)	
	remote forced data	bit 3: 0 (normal)/1 (forced)	
	local forced data	bit 4: 0 (normal)/1 (forced)	
	roll over	bit 5: 0	Not used
	discontinuity	bit 6: 0 (normal)/1 (discontinuity)	-
	reserved	bit 7: 0	Not used

Binary Output Status and Analog Output Status

The **Binary_Output_Status** and **Analog_Output_Status** are applied in the master, which are used to save the latest value, state (flag), and timestamp.

This figure shows the binary output status:

The screenshot shows the **Binary_Output_Status** configuration window with the following fields and values:

- Point Number: 0
- Point Count: 1
- CPU Register Type: %MW
- CPU Register Address: 0
- Variable Name: -
- Store To CPU: Value only
- Static Variation: Value only (dropdown menu is open showing options: Value only, Value with time, Value with flag, Value with flag and time)
- Event routing:
 - Channel: Value with flag and time
 - Session: 0
 - Point number: 0
- Event Class Mask: Class0 Class1 Class2 Class3
- Default Event Variation: g11v1Binary Out No Tim

This figure shows the analog output status:

NOTE: Floating point values (scientific notation) can be entered for the **deadband**.

Behavior of a Binary Output

The configuration applies **latch on/off**, **pulse on**, and **close/trip pulse on**:

TCC (Trip-Close Code)	Operation type field	Control code	Point model in outstation
None	pulse on	01 hex	activation
	latch on	03 hex	latch complement
	latch off	04 hex	
Close	pulse on	41 hex	two's complement
Trip		81 hex	

This figure shows the selection of control code type:

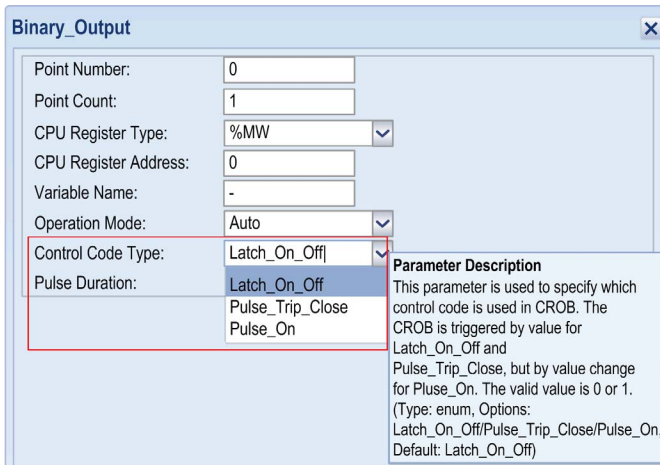

- The DNP3 master only provides on-time configuration, but does not provide configured off-time and count. The DNP3 slave also only applies pulse on which the count is 1 and the off-time value is 0.
- Two's complement **trip** and **close** are provided for a single index in the DNP3 master, but two separately physical outputs in the DNP3 slave. For example, a **close/pulse on** request for a specific DNP3 index is mapped to a specific relay output, whereas a **trip/pulse on** request for the same DNP3 index is mapped to another different relay output which follows the specific relay output (close) in the RTU module.

CROB sent in DNP3 master	Point number in DNP3 master	Point number in DNP3 slave
Pulse on	0	0
Trip/Pulse on	0	1
Close/Pulse on	2	2
Trip/Pulse on	2	3
Close/Pulse on	n+2	n+2
Trip/Pulse on	n+2	n+2+1

In the DNP3 slave, it is decided by configuration whether the point index applies **trip/close** request. As the **trip/close** need to bind a couple of points, the point count is even in the configuration.

The following figure shows the selection of TCC:

The screenshot shows a configuration window titled "Binary_Output". It contains several fields and checkboxes:

- Point Number: 0
- Point Count: 1
- CPU Register Type: %MW
- CPU Register Address: 0
- Variable Name: -
- Event Class Mask: Class0 Class1 Class2 Class3
- TCC: None (highlighted with a red box)
- Default Static Variation: None
- Default Event Variation: Trip_Close

TCC parameter: The usage of Trip_Close mode depends on the **Trip-Close Mode** (see page 282) parameter setting (**Channel** → **Session** → **Advanced Parameter**).

When Trip-Close Mode is in Even Mode, the behavior is as follows: the close command controls the even point and the trip command controls the odd point.

When Trip-Close Mode is in Consecutive Mode, the behavior is as follows: the binary output occupies two registers in the CPU memory (%MWs or %Ms). The low register is for the close command and the high register is for the trip command.

- CROB usage in master

Op type field	Trigger mechanism	Description
Close/Pulse_on	any value change (0...65535)	pulse on if value change
Latch_on	0 to 1	latch on
Latch off	1 to 0	latch off
Close/Pulse_on	0 to 1	pulse on for close output
Trip/Pulse_on	1 to 0	pulse on for trip output

- Binary output in DNP3 slave is only updated in CPU register only after receiving command from DNP3 master, but not synchronized cyclically. Keep the corresponding CPU register not written any more.

Long and Short Pulses of Binary Outputs

This figure shows the pulse duration setting of the master:

The screenshot shows a configuration window titled "Binary_Output" with a close button (X) in the top right corner. The window contains several configuration fields:

- Point Number: 0
- Point Count: 1
- CPU Register Type: %MW (dropdown menu)
- CPU Register Address: 0
- Variable Name: -
- Operation Mode: Auto (dropdown menu)
- Control Code Type: Latch_On_Off (dropdown menu)
- Pulse Duration: 200 (text input field, highlighted with a red border)

A "Parameter Description" box is located at the bottom right of the window, containing the following text:

Parameter Description
This is the duration, expressed as the number of milliseconds, that the output remains active. (Type: integer, Min:0, Max: 60000, Default: 0)

This figure shows the pre-configured pulse duration of the slave:

The screenshot shows a configuration window for slave parameters with the following fields:

- Unsol Class 2 Max Delay(ms): 5000
- Unsol Class 3 Max Delay(ms): 5000
- Unsol Max Retries: 3
- Unsol Retry Delay(ms): 5000
- Unsol Offline Retry Delay(ms): 30000
- Delete Oldest Event:
- Pulse Duration: 100 (text input field, highlighted with a red border)

A "Parameter Description" box is located at the bottom right of the window, containing the following text:

Parameter Description
Specify pulse's width in milliseconds
(Type: integer, Min: 0, Max: 4294967295, Default: 100)

NOTE: The outstation uses the entered pulse duration. The value 0 indicates that the device uses a pre-configured value.

Set Measured Value

Apply analog input dead band (**obj34**) to set deadhead of measured value. The parameters of the measured points are activated immediately after the DNP3 slave receives the request from the DNP3 master.

For DNP3 **obj34**, there is no qualifier to set as it only applies the parameter **deadband**. Set the static variation and point number at the same setting of the analog input. Analog input **deadband** is applied both on the DNP3 master and the DNP3 slave. DNP3 master uses it to store the current value which is reported in the response of read requests, the DNP3 slave uses it to display the current **deadband** value which can be controlled by the master through the analog input **deadband** control block.

This figure shows the parameter point setting of **deadband**:

The screenshot shows a configuration window titled "Analog_Input_Deadband". It contains the following fields:

Point Number:	0
Point Count:	1
CPU Register Type:	%MW
CPU Register Address:	0
Variable Name:	-

The "Point Number" field is highlighted with a red box.

This figure shows the parameter point setting of **deadband** control block:

The screenshot shows a configuration window titled "Ana_Input_DBand_Ctrl". It contains the following fields:

Point Number:	0
Point Count:	1
CPU Register Type:	%MW
CPU Register Address:	0
Variable Name:	-
Default Static Variation:	g34v1 16bit AI Deadband

The "Point Number" field is highlighted with a red box. The "Default Static Variation" dropdown menu is open, showing the following options:

- g34v1 16bit AI Deadband
- g34v1 16bit AI Deadband
- g34v2 32bit AI Deadband
- g34v3 Short Float AI Deadband

The "g34v1 16bit AI Deadband" option is selected.

Generating Events on Demand

This feature generates events on demand regardless of value and state. Data is pushed to the event queue even if the tag value has not changed. It generates events for any specified point type.

Gen_Events can be created only for DNP3 Slave/Server; select Data Mapping:

Parameter	Value Scope	Default Value	Definition
Object Group	Binary Input Double Input Binary Counter Analog Input Binary Output Analog Output	Binary Input	specifies the object group whose event must be generated on demand
Start Point Number	0..16777215	0	specifies the start point number of the specified object group
Point Count	1..5000	5000	specifies the point number to generate events 5000: the actual count depends on the point number of the object group's configuration)
CPU Register Type	%MW	%MW	indicates the register type in the CPU to map points to; only the %MW type is supported
CPU Register Address	0...32464	0	indicates the start address of the register in the CPU. Effective for the located variables only
Variable Name	-	-	indicates the name of the located register

Analog input supports events in either Class1, Class2, or Class3 options. If the value of Gen_Events register has changes, the advanced RTU module records the events for the Analog Input specified in the configuration although its value has no change.

It is possible to control Gen_Events in SCADA after mapping the CPU register with Binary Output.

Clearing Events on Demand

`Clear_Events` supports a new point type which clears the event buffer in the DNP3 Server/Slave. It enables the user to clear the events buffer in a local or remote SCADA through mapping memory.

`Clear_Events` can be created only for DNP3 Slave/Server; select Data Mapping.

When the value of `Clear_Events` register has changes, the advanced RTU module clears the events of the object group in configuration.

Parameter	Value Scope	Default Value	Definition
Object Group	All Objects Binary Input Double Input Binary Counter Analog Input Binary Output Analog Output	All Objects	specifies the object group whose event must be cleared on demand
Channel Number	0..255	255 (all the channels)	specifies the channel number to clear (it depends on channel configuration)
CPU Register Type	%MW	%MW	indicates the register type in the CPU to map points to; only the %MW type is supported
CPU Register Address	0..32464	0	indicates the start address of the register in the CPU. Effective for the located variables only
Variable Name	–	–	indicates the name of the located register

DNP3 Data Object Mapping

Introduction

Depending on the data object type and protocol profile selection, different configuration fields are used in the definitions of different data object mapping items.

Exchangeable CPU Data Object

Located and unlocated variables can both be exchanged between the CPU and the RTU module after you have defined and managed the memory map of the CPU to exchange data with the module.

The CPU data objects are mapped and only linked for the RTU module purpose.

 WARNING

UNINTENDED EQUIPMENT OPERATION

Do not create an instance of redundant data access.

Failure to follow these instructions can result in death, serious injury, or equipment damage.

Data Exchanging Performance

To sustain a high rate of data exchange, we recommend that you define the RTU memory for data objects in a continuous sequence.

NOTE: For each unlocated variable, the configured length cannot exceed 1000 bytes.

Module Behavior after Control Expert Application Transfer

NOTE:

After a Control Expert application transfer, the following behavior occurs:

- The RTU protocol service is not restarted (it is only restarted if the RTU module IP address has been modified).
- Depending on the Control Expert application settings, PLC data could be either reset or not.
- Unexpected new events may occur in case of data reset after download.

To avoid this behavior, uncheck the Initialize %MWi on cold start option in the PLC configuration screen of the Control Expert application.

If you want to reset the RTU protocol service, use the menu Reset Communication in the Web site. It is recommended in case of modification of the number %M or %MW variables in Control Expert application.

Dialog Box

This figure shows the dialog box for configuring the data object mapping for an item with the example data type M_SP for the DNP3 slave/server:

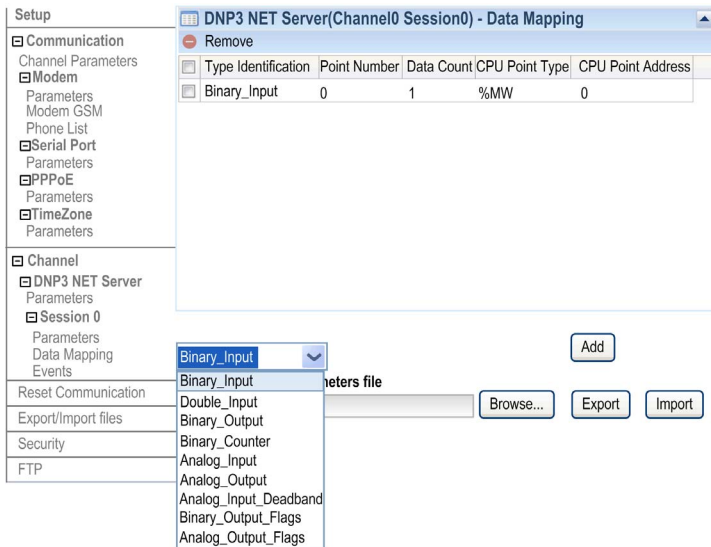

Import/Export

Data object Mapping items can be exported (*see page 212*) as a profile in the *.XSY format. Such files can be imported into Control Expert software.

Predefined Command List

The required input fields are requested to define a predefined command item for DNP3 master/DNP3 NET client (*see page 315*).

Static Variation Name of DNP3

Data object type	Static variation
Binary Input	g1v1 Binary In
	g1v2 Binary In Flag
Double Input	g3v1 Double In
	g3v2 Double In Flag

Data object type	Static variation
Binary Output	g10v1 Binary Out
	g10v2 Binary Out Flag
Binary Counter	g20v1 32bit Counter
	g20v2 16bit Counter
	g20v5 32bit Ctr No Flag
	g20v6 16bit Ctr No Flag
Frozen Counter	g21v1 32bit Frozen Ctr Flag
	g21v2 16bit Frozen Ctr Flag
	g21v5 32bit Frozen Ctr Flag Time
	g21v6 16bit Frozen Ctr Flag Time
	g21v9 32bit Frozen Counter
	g21v10 32bit Frozen Counter
Analog Input	g30v1 32bit Analog In
	g30v2 16bit Analog In
	g30v3 32bit AI No Flag
	g30v4 16bit AI No Flag
	g30v5 Short Float AI
Analog Input Deadband	g34v1 16bit AI Deadband
	g34v2 32bit AI Deadband
	g34v3 Short Float AI Deadband
Analog Input Dband_Ctrl	g34v1 16bit AI Deadband
	g34v2 32bit AI Deadband
	g34v3 Short Float AI Deadband
Analog Output	g40v1 32bit Analog Output
	g40v2 16bit Analog Output
	g40v3 Short Float AO
Read_Group	-
Freeze_Counter	-
Unsolicited_Class	-
Time_Sync	-
Restart	-
Integrity_Poll	-
Gen_Events	-
Clear_Events	-

Event Variation Name of DNP3

Data object type	Event variation
Binary Input	g2v1 Binary Input No Time
	g2v2 Binary Input With Time
	g2v3 Binary Input Relative Time
Double Input	g4v1 Double Input No Time
	g4v2 Double Input With Time
	g4v3 Double Input Relative Time
Binary Output	g11v1 Binary Out No Time
	g11v2 Binary Out With Time
Binary Counter	g22v1 32bit Counter No Time
	g22v2 16bit Counter No Time
	g22v5 32bit Counter With Time
	g22v6 16bit Counter With Time
Frozen Counter	g23v1 32bit Frozen Ctr No Time
	g23v2 16bit Frozen Ctr No Time
	g23v5 32bit Frozen Ctr With Time
	g23v6 16bit Frozen Ctr With Time
Analog Input	g32v1 32bit Analog In No Time
	g32v2 16bit Analog In No Time
	g32v3 32bit Analog In With Time
	g32v4 16bit Analog In With Time
	g32v5 Short Float AI No Time
	g32v7 Short Float AI With Time
Analog Output	g42v1 32bit Analog Out No Time
	g42v2 16bit Analog Out No Time
	g42v3 32bit Analog Out With Time
	g42v4 16bit Analog Out With Time
	g42v5 Short Float AO No Time
	g42v7 Short Float AO With Time

This figure shows the data type:

The image shows a configuration window titled "Analog_Input" with a close button (X) in the top right corner. The window contains several input fields and a dropdown menu:

- Point Number: 1
- Point Count: 1
- CPU Register Type: %MW (dropdown)
- CPU Register Address: 0
- Variable Name: -
- Event Class Mask: Class0 Class1 Class2 Class3
- Deadband: 0.0
- CPU Reg Mapping: Value only
- Default Static Variation: g30v1 32bit Analog In (dropdown menu is open)
- Default Event Variation: g30v2 16bit Analog In (dropdown menu is open)

The dropdown menu for "Default Static Variation" is open, showing the following options:

- g30v1 32bit Analog In
- g30v2 16bit Analog In
- g30v3 16bit AI No Flag
- g30v4 32bit AI No Flag
- g30v5 Short Float AI

DNP3 Event Queue Setting

Event Queue Setting Page

This figure shows the dialog box for configuring the event queue setting for an item with the example data type Binary_Input for DNP3 slave/server:

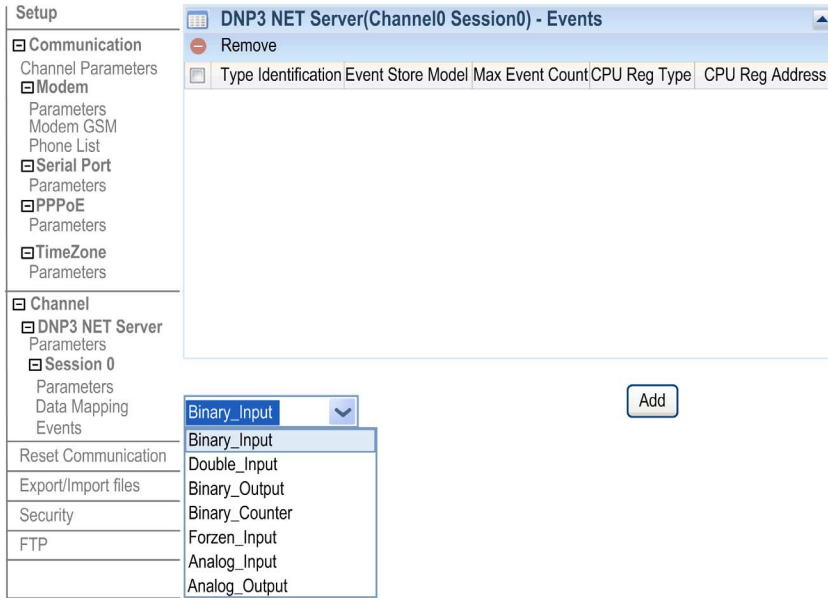

This figure shows the dialog box for configuring the event queue setting:

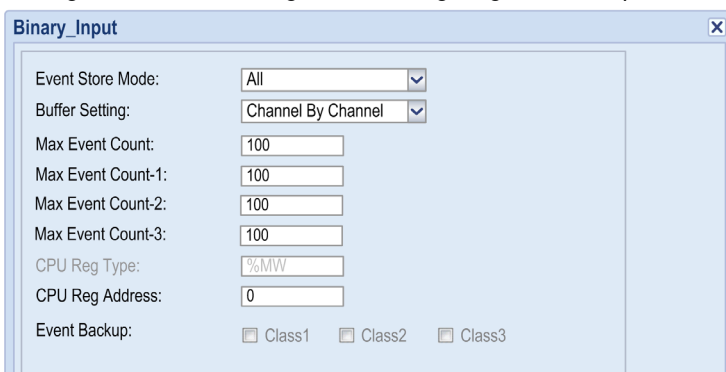

Parameter	Value scope	Default value	Description
Event Store Mode	All/Most Recent	All	stores all event in queue or only stores most recent event for each object
Buffer Setting	All Channels, By Channel	All Channels	specifies whether the buffer size is configured by channel or not; all channels support up to 10,000 events
Max Event Count	1...65535	100	supported event count by channel; in whole, up to 100,000 events are supported
Max Event Count-n	0...65535	1	supports event count for virtual channel #n
CPU Reg Type	%MW	%MW	status register type in CPU
CPU Reg Address	0...32464	0	address of event status register in CPU
Event Backup	checked/unchecked	unchecked	what is backed up in event of power loss

NOTE: When BMXNOR0200H module uses IEC/DPN3 server or slave, the events status is mapped into **CPU Register Address**. One event status occupies two %MW. The first %MW is for event number and the second is used to save overflow bits. If the number of channels is more than one, the events of virtual channel follows the first channel event status.

Example of the setting of the event status:

- Channel Count: 2
- CPU Reg Address: 1000
- Channel 0 Event Status: %MW1000/%MW1001
- Channel 1 Event Status: %MW1002/%MW1003

DNP3 Master/ DNP3 Net Client

Predefined Master Command

The predefined master command of the DNP3 master contains these fields:

Command	Status	Meaning
Read_Class	Yes	read class command
Read_Group	Yes	read group command
Freeze_Counter	Yes	freeze counter command
Unsolicited_Class	Yes	class unsolicited command
Time_Sync	Yes	time synchronization command
Restart	Yes	restart command

Command Implementation Method

Commands can be mapped to the CPU memory, either:

- 32-bit CPU register (command and status) through %MW. Both the command and status are 16 bits.
- 64-bit CPU register (command and status) through %MW. Both command and status are 32 bits.

Commands are implemented each time when the value in the configured CPU memory changes. This allows the user to control easily the command implementation by changing the value in the CPU memory.

NOTE: In DNP3 master/client, the binary output is triggered to send out on the change of low byte of CPU mapping (%MW) since firmware V1.6 (instead of a change of last bit of CPU mapping (%MW) in previous firmware versions).

Command Status Register

Certain commands have a status register that lets the user know if the command was successfully executed. The status register is a 16-bit word. For example, if a command is mapped to CPU register %MW1, the corresponding status register is automatically mapped to %MW2.

NOTE: When a command is mapped to a register and the command has a command status, the status register is automatically mapped to the following register.

If a command has a result, the low byte of the status register increments automatically to indicate that the status is for the command. The high byte is the status of the command.

NOTE: If the high byte of command status has a result 0, this means that it has completed successfully.

A DNP3 command status register contains these fields:

Status value	Description
0	The command has completed successfully.
1	A response was received but the requested command is not yet complete.
2	The command did not transmit as expected.
3	The command has timed out.
4	The command has been canceled.
5	The response to a select or an execute did not echo the request.
6	The command did not execute.
7	The response to a command had IIN bits set indicating that the command was not executed.

DNP3 Data Length & Mapping Orientation

DNP3

Data object type	Data length (bits)	Orientation	
		Master	Slave/Server
Binary Input	1	Mod -> CPU	CPU -> Mod
Double Input	2	Mod -> CPU	CPU -> Mod
Binary Output	1	CPU -> Mod	Mod -> CPU
Binary Counter	32	Mod -> CPU	CPU -> Mod
Analog Input	32	Mod -> CPU	CPU -> Mod
Analog Output	32	CPU -> Mod	Mod -> CPU
Read_Class	16	CPU -> Mod	-
Read_Group	16	CPU -> Mod	
Freeze_Counter	16	CPU -> Mod	
Unsolicited_Class	16	CPU -> Mod	
Time_Sync	16	CPU -> Mod	
Restart	16	CPU -> Mod	
Gen_Events	16	-	CPU -> Mod
Clear_Events	16	-	CPU -> Mod

DNP3 Data Object Type Mapped to Control Expert EDT/DDT

Introduction

The RTU data object is mapped to a Control Expert variable with EDT/DDT while exporting data objects mapping a relationship to an *.XSY file. In addition to the variables you define, the .XSY file contains predefined DDT types for timestamp formats.

DNP3

Data object type	Data length (bits)	Control Expert EDT/DDT	Protocol
Binary Input	1	WORD	master/slave
Double Input	2	WORD	
Binary Counter	32	DWORD	
Analog Input	32	DINT/REAL	
Analog Input Deadband	32	DINT/REAL	
Binary Input + Time	1	WORD+CP56	
Double Input + Time	2	WORD+CP56	
Binary Counter + Time	32	DWORD+CP56	
Analog Input + Time	32	DINT/REAL+CP56	
Binary Input + Flag	1	WORD+WORD	
Double Input + Flag	2	WORD+WORD	
Binary Counter + Flag	32	DWORD+DWORD	
Analog Input + Flag	32	DINT/REAL+DWORD	
Binary Input + Flag + Time	1	WORD+WORD+CP56	
Double Input + Flag + Time	2	WORD+WORD+CP56	
Binary Counter + Flag + Time	32	DWORD+DWORD+CP56	
Analog Input + Flag + Time	32	DINT/REAL+DWORD+CP56	
Binary Output Status	1	WORD	master
Binary Output Status + Time	1	WORD+CP56	
Binary Output Status + Flag	1	WORD+WORD	slave
Binary Output Status + Flag + Time	1	WORD+WORD+CP56	
Binary Output Status Flag	8	WORD	master/slave
Analog Output Status	32	DINT/REAL	
Analog Output Status + Time	32	DINT/REAL+CP56	master
Analog Output Status + Flag	32	DINT/REAL+DWORD	
Analog Output Status + Time	32	DINT/REAL+DWORD+CP56	

Data object type	Data length (bits)	Control Expert EDT/DDT	Protocol
Analog Output Status Flag	8	WORD	slave
Binary Output + Status	1	WORD+WORD	master
Analog Output + Status	32	DINT/REAL+DWORD	
Read_Class + Status	16	WORD+WORD	
Read_Group + Status	16	WORD+WORD	
Freeze_Counter + Status	16	WORD+WORD	
Unsolicited_Class + Status	16	WORD+WORD	
Time_Sync + Status	16	WORD+WORD	
Restart + Status	16	WORD+WORD	
Gen_Events	16	WORD+WORD	
Clear_Events	16	WORD+WORD	
Integrity_Poll + Status	16	WORD+WORD	
Analog Input Dband + Status	32	DINT/REAL+DWORD	

NOTE: The DNP type of analog I/O data objects can be converted to REAL according to your application requirements.

NOTE: The advanced RTU module only supports to send *Integrity Poll* command periodically. It can be realized by programming in PLC application. It is recommended that the period in PLC scan period be longer than 200 milliseconds.

CP56Time2a

CP56 Element	Type	Definition
ms (milliseconds)	WORD	2 bytes for milliseconds from 0 to 59999
minute	BYTE	Bit 0...5: Minutes from 0 to 59 Bit 6: Indicates Genuine Time or Substituted Time. <ul style="list-style-type: none"> ● 0 = the time tag was added to the information object when it was acquired by the RTU (Genuine Time). ● 1 = the time tag was substituted by intermediate equipment, such as concentrator stations, or the controlling station itself (Substituted Time). Bit 7: Indicates the validity of the time stamp when time synchronization is lost. <ul style="list-style-type: none"> ● 0 = Valid Time ● 1 = Invalid Time
hour	BYTE	Bit 0...4: Hours from 0 to 23 Bit 5: Reserved (always 0) Bit 6: Reserved (always 0) Bit 7: Indicates the present valid time. The summer bit (SU) may be used as additional information. <ul style="list-style-type: none"> ● 0 = Standard Time ● 1 = Summer Time
monthday	BYTE	Bit 0...4: Day of month from 1 to 31 Bit 5...7: Day of week from 1 to 7
month	BYTE	Bit 0...3: Months from 1 to 12 Bit 4...7: Reserved (always 0)
year	BYTE	Bit 0...6: Years from 0 to 99 (1/1/xx00 to 31/12/xx99) Bit 7: Reserved (always 0)

The `Summer Bit` parameter is supported in the timestamp IEC60870 and can be set in the CPU mapping register with the DDT `CP56Time2a` parameter.

NOTE: The advanced RTU module uses the summer bit to determine the time in the time zone. The SCADA must also set the summer bit for time synchronization.

Chapter 14

Web Designer Configuration

Introduction

This chapter describes the Web Designer configuration software for setting up the variable list and additional functions such as DataLogging, email services, and data table lists.

Refer to *Web Designer for FactoryCast, User Manual* ([see page 14](#)) for a detailed Web Designer presentation.

What Is in This Chapter?

This chapter contains the following topics:

Topic	Page
Create a Project	322
PLC Device Configuration	325
Data Editor Configuration	326
Transfer	327

Create a Project

Web Designer Project Creation Wizard

Once the project is created, the Web Designer treeview provides the classic menus, data tables, services, and website, but without the graphic screens:

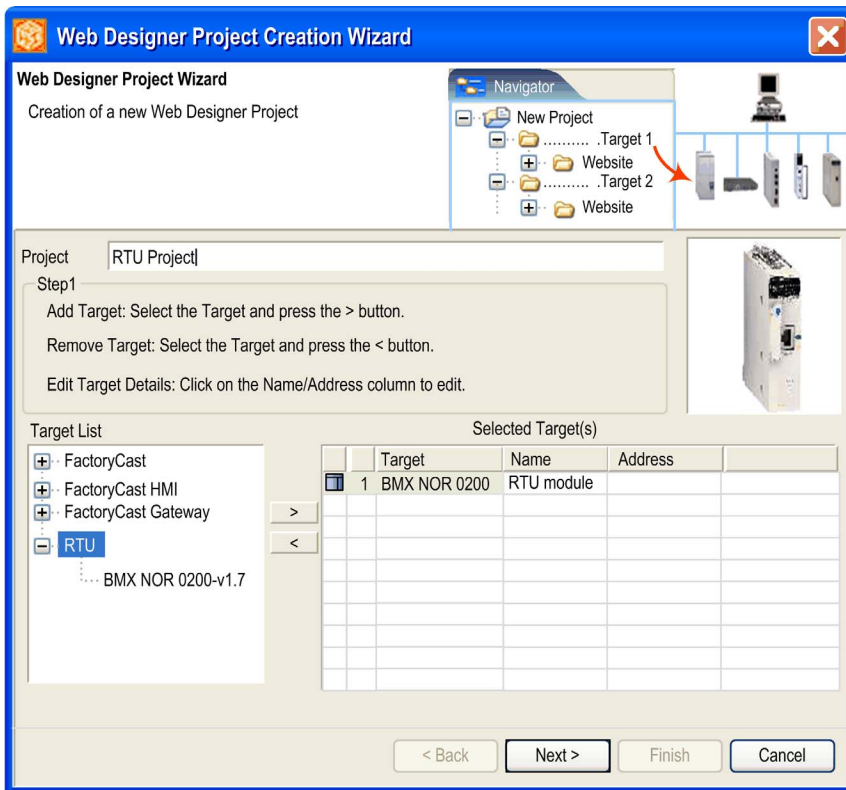

When you select the BMXNOR0200H module in the **Target List**, the Modicon M340 is available as a device in the **Device List**:

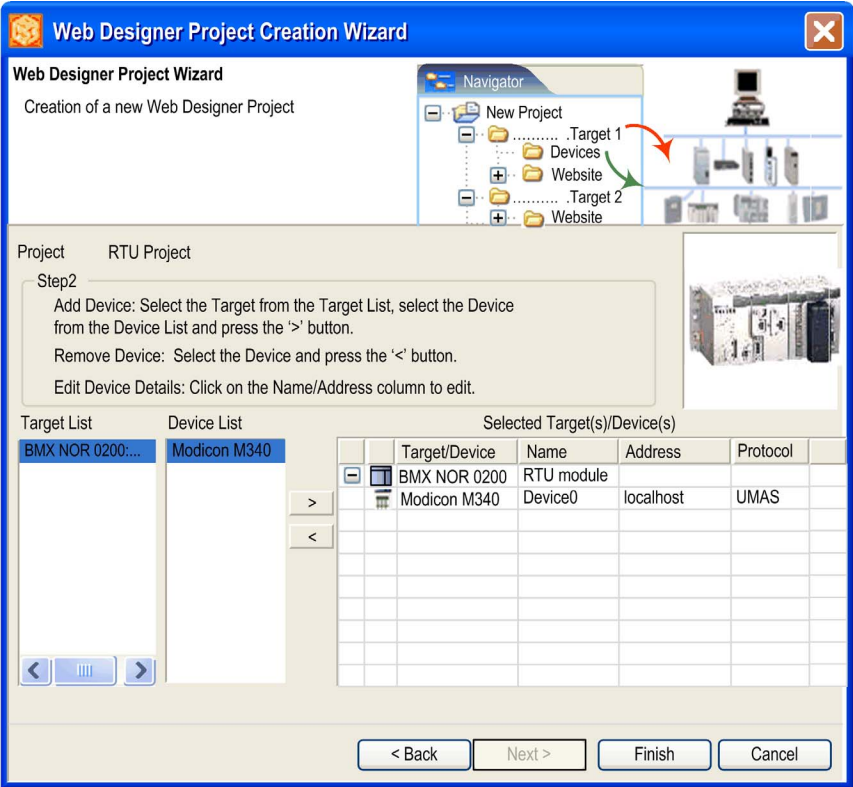

Once the project is created, the Web Designer treeview provides the classic menus, data tables, services, and website, but without the graphic screens:

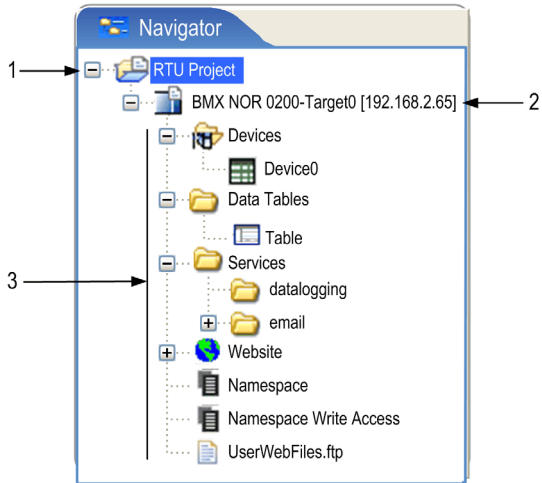

- 1 Name of the project
- 2 Target associated with the project
- 3 Directories associated with the project

PLC Device Configuration

Variables List Configuration

The BMXNOR0200H module does not support extracted bit variables. An extracted bit is a bit in %MW or %SW, for example %MW900.2 of BOOL type. The EBOOL type can be used.

Email, SMS and datalogging do not work with the import of extracted bits.

NOTE: Do not use extracted bit variables.

The BMXNOR0200H module supports STU/XVM program file imports. It allows you to create a customized list of variables that can be used in other services such as datalogging or email services and in data table animations:

No.	Symbol	Address	Type	Access	Persistent	Value	Comment
1	variable1	%MW1	INT	R	<input type="checkbox"/>		
2	variable2	%MW2	INT	R	<input type="checkbox"/>		
3	variable3	%MW3	INT	R	<input checked="" type="checkbox"/>		
4	variable4	%MW4	INT	R	<input type="checkbox"/>		
5	variable5	%MW5	INT	R	<input type="checkbox"/>		
6	variable6	%MW6	INT	R	<input type="checkbox"/>		

NOTE: Check the Persistent box for the variables used in datalogging or email services.

Data Editor Configuration

Create Data Editor Tables

After the variable repository is created, you can import the variables to the Data table editor. It allows you to create tables that monitor values on the website. These tables need to be transferred to the target to be used online:

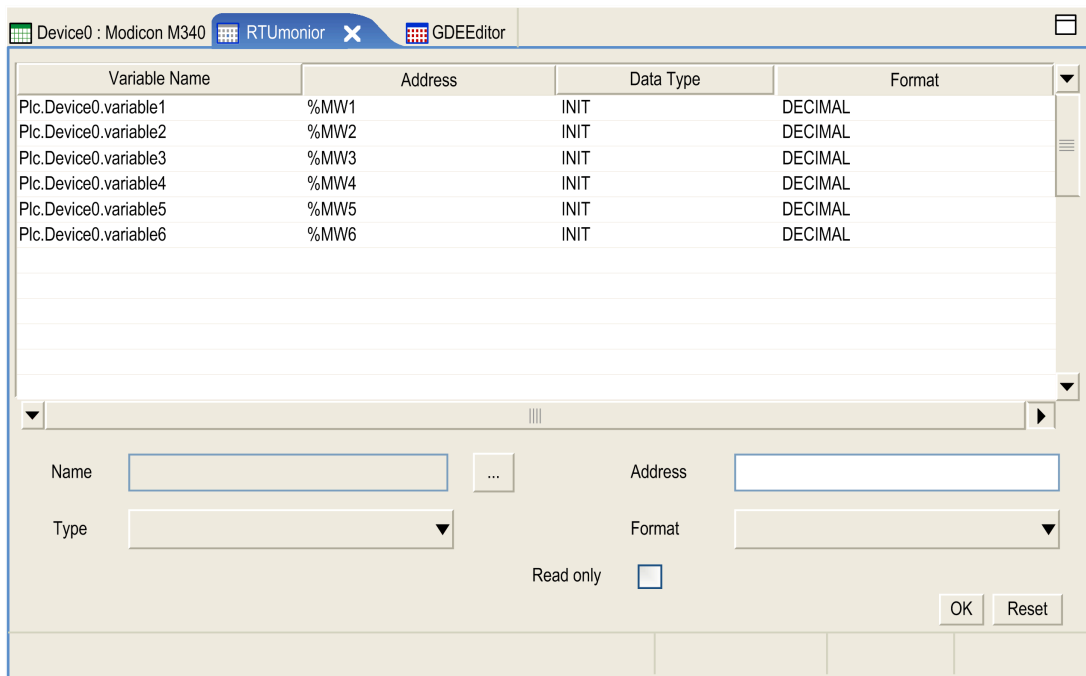

Variables that can be written are accessible only by trained personnel (password protect).

WARNING

UNINTENDED OPERATION

Apply password protection to limit access to the Data Editor.

Failure to follow these instructions can result in death, serious injury, or equipment damage.

Transfer

Transfer the Project

Use the transfer function to transfer the project to the BMXNOR0200H module. The transfer can run in two directions, indicated by your selection in the **Direction** column of the **Transfer Status** dialog box. You can transfer from the PC to the target or from the target to the PC:

	Direction	PC	Direction	Address IP
[-]	Download	BMX NOR 0200-T...		192.168.2.65
<input checked="" type="checkbox"/>	Target Type	BMX NOR 0200	--->	BMX NOR 0200
<input checked="" type="checkbox"/>	HTML Version	1.0	--->	1.0
<input checked="" type="checkbox"/>	Firmware Version	1.0	--->	1.0
<input checked="" type="checkbox"/>	Web Designer Version 2.2		--->	2.2

Selection

Transfer Website Location: SDCard ▼

Transfer Only Modified Files

Transfer rdt and gdt Files

Transfer Configuration Files

Transfer

Cancel

NOTE: The Web Designer does not transfer or reset protocols. Use the web interface of the BMXNOR0200H module.

Appendices



Introduction

These technical appendices supplement the information in this guide.

What Is in This Appendix?

The appendix contains the following chapters:

Chapter	Chapter Name	Page
A	Interoperability	331
B	Ethernet Language Objects	395

Appendix A

Interoperability

About this Chapter

This chapter describes the specific implementation of protocols with the BMXNOR0200H module.

What Is in This Chapter?

This chapter contains the following topics:

Topic	Page
IEC 60870-5-101 Interoperability for BMXNOR0200H as Master	332
IEC 60870-5-101 Interoperability for BMXNOR0200H as Slave	342
IEC 60870-5-104 Interoperability for BMXNOR0200H as Client	352
IEC 60870-5-104 Interoperability for BMXNOR0200H as Server	361
DNP3 Interoperability for BMXNOR0200H as Master	370
DNP3 Interoperability for BMXNOR0200H as Slave	381

IEC 60870-5-101 Interoperability for BMXNOR0200H as Master

Introduction

The purpose of this information is to describe the specific implementation of the IEC 60870-5-101 within BMXNOR0200H as master.

This information and the documents listed below provide detailed information on how to communicate with BMXNOR0200H as master via IEC 60870-5-101

- IEC 60870-5-101 = Companion standard for basic telecontrol tasks
- IEC 60870-5-5 = Basic Application Functions
- IEC 60870-5-2 = Link Transmission Procedures
- IEC 60870-5-4 = Definition and Coding of Application Information Elements
- IEC 60870-5-3 = General Structure of Application Data
- IEC 60870-5-1 = Transmission Frame Formats

Interoperability

This companion standard presents sets of parameters and alternatives from which you select subsets to implement particular telecontrol systems. Certain parameter values, such as the number of octets in the COMMON ADDRESS of ASDUs represent mutually exclusive alternatives. This means that only one value of the defined parameters is admitted per system. Other parameters, such as the listed set of different process information in command and in monitor direction allow the specification of the complete set or subsets, as appropriate for given applications. This Clause summarizes the parameters of the previous Clauses to facilitate a suitable selection for a specific application. If a system is composed of equipment stemming from different manufacturers, it is necessary that all partners agree on the selected parameters.

The selected parameters are marked as follows:

-	Function or ADSU is not used
X	Function or ADSU is used

System or Device

-	System definition
X	Controlling station definition (master)
-	Controlled station definition (slave)

Network Configuration

X	Point-to-point	X	Multipoint-part line
X	Multi point-to-point	X	Multipoint-star

Physical Layer

Transmission speed (control direction)							
Unbalanced interchange Circuit V.24/V.28 Standard		Unbalanced interchange Circuit V.24/V.28 Recommended if >1200-bit/s		Balanced interchange Circuit X.24/X.27			
-	100 bit/s	X	2400 bit/s	X	2400 bit/s	-	56000 bit/s
-	200 bit/s	X	4800 bit/s	X	4800 bit/s	-	64000 bit/s
X	300 bit/s	X	9600 bit/s	X	9600 bit/s		
X	600 bit/s			X	19200 bit/s		
X	1200 bit/s			X	38400 bit/s		
Unbalanced interchange Circuit V.24/V.28 Standard		Unbalanced interchange Circuit V.24/V.28 Recommended if >1200-bit/s		Balanced interchange Circuit X.24/X.27			
-	100 bit/s	X	2400 bit/s	X	2400 bit/s	-	56000 bit/s
-	200 bit/s	X	4800 bit/s	X	4800 bit/s	-	64000 bit/s
X	300 bit/s	X	9600 bit/s	X	9600 bit/s		
X	600 bit/s			X	19200 bit/s		
X	1200 bit/s			X	38400 bit/s		

Link Layer

Frame format FT 1.2, single character 1 and the fixed time out interval are used exclusively in this companion standard.

When using an unbalanced link layer, the following ASDU types are returned in class 2 messages (low priority) with the indicated causes of transmission:

Link transmission procedure		Address field of link	
X	Balance transmission	X	Not present (balanced transmission only)
X	Unbalance transmission	X	One octet
		X	Two octets
		-	Structured
		-	Unstructured
Frame length			
255	Maximum frame length L (control direction)		
255	Maximum frame length L (monitor direction)		
Configurable	Time during which repetitions are permitted (Trp) or numbers of repetitions		
X	The standard assignment of ADSUs to class 2 messages is used as follows		
Type identification		Cause of transmission	

9/11/13/21	<1>
-	A special assignment of ADSUs to class 2 messages
Type identification	Cause of transmission
-	-

Application Layer

Transmission mode for application data			
Mode 1 (least significant octet first), as defined in 4.10 of IEC 60870-5-4, is used exclusively in this companion standard			
Common address of ASDU			
X	One octet	X	Two octets
Information object address			
X	One octet	-	Structured
X	Two octets	-	Unstructured
X	Three octets		
Cause of transmission			
X	One octet	X	Two octets (with originator address). Set to zero in case of no originator address

Process information in monitor direction			
X	<1>	Single-point information	M_SP_NA_1
X	<2>	Single-point information with time tag	M_SP_TA_1
X	<3>	Double-point information	M_DP_NA_1
X	<4>	Double-point information with time tag	M_DP_TA_1
X	<5>	Step position information	M_ST_NA_1
X	<6>	Step position information with time tag	M_ST_TA_1
X	<7>	Bitstring of 32 bit	M_BO_NA_1
X	<8>	Bitstring of 32 bit with time tag	M_BO_TA_1
X	<9>	Measured value, normalized value	M_ME_NA_1
X	<10>	Measured value, normalized value with time tag	M_ME_TA_1
X	<11>	Measured value, scaled value	M_ME_NB_1
X	<12>	Measured value, scaled value with time tag	M_ME_TB_1
X	<13>	Measured value, short floating point value	M_ME_NC_I
X	<14>	Measured value, short floating point value with time tag	M_ME_TC_1
X	<15>	<15> Integrated totals	M_IT_NA_1
X	<16>	<16> Integrated totals with time tag	M_IT_TA_1

Process information in monitor direction			
-	<17>	<17> Event of protection equipment with time tag	M_EP_TA_1
-	<18>	<18> Packed start events of protection equipment with time tag	M_EP_TB_1
-	<19>	Packed output circuit information of protection equipment with time tag	M_EP_TC_1
-	<20>	Packed single-point information with status change detection	M_PS_NA_1
-	<21>	Measured value, normalized value without quality descriptor	M_ME_ND_1
X	<30>	Single-point information with time tag CP56Time2a	M_SP_TB_1
X	<31>	Double-point information with time tag CP56Time2A	M_DP_TB_1
X	<32>	Step position information with time tag CP56Time2A	M_ST_TB_1
X	<33>	Bitstring of 32 bit with time tag CP56Time2A	M_BO_TB_1
X	<34>	Measured value, normalized value with time tag CP56Time2A	M_ME_TD_1
X	<35>	Measured value, scaled value with time tag CP56Time2A	M_ME_TE_1
X	<36>	Measured value, short floating point value with time tag CP56Time2A	M_ME_TF_1
X	<37>	Integrated totals with time tag CP56Time2A	M_IT_TB_1
-	<38>	Event of protection equipment with time tag CP56Time2A	M_EP_TD_1
-	<39>	Packed start events of protection equipment with time tag CP56Time2A	M_EP_TE_1
-	<40>	Packed output circuit information of protection equipment with time tag CP56Time2a	M_EP_TF_1

Process information in control direction			
X	<45>	Single command	C_SC_NA_1
X	<46>	Double command	C_DC_NA_1
X	<47>	Regulating step command	C_RC_NA_1
X	<48>	Set point command, normalized value	C_SE_NA_1
X	<49>	Set point command, scaled value	C_SE_NB_1
X	<50>	Set point command, short floating point value	C_SE_NC_1
X	<51>	Bitstring of 32-bit	C_BO_NA_1

System information in monitor direction			
X	<70>	End of initialization	M_EI_NA_1

System information in control direction			
X	<100>	Single command	C_IC_NA_1
X	<101>	Double command	C_CI_NA_1
X	<102>	Regulating step command	C_RD_NA_1
X	<103>	Set point command, normalized value	C_CS_NA_1
X	<104>	Set point command, scaled value	C_TS_NB_1
X	<105>	Set point command, short floating point value	C_RP_NC_1
-	<106>	Bitstring of 32-bit	C_CD_NA_1

Parameter in control direction			
X	<110>	Parameter of measured value, normalized value	P_ME_NA_1
X	<111>	Parameter of measured value, scaled value	P_ME_NB_1
X	<112>	Parameter of measured value, short floating point value	P_ME_NC_1
X	<113>	Parameter activation	PC_AC_NA_1

File transfer			
-	<120>	File ready	F_FR_NA_1
-	<121>	Section ready	F_SR_NA_1
-	<122>	Call directory, select file, call file, call section	F_SC_NA_1
-	<123>	Last section, last segment	F_LS_NA_1
-	<124>	Ack file, ack section	F_AF_NA_1
-	<125>	Segment	F_SG_NA_1
-	<126>	Directory	F_DR_NA_1

Type identification		Cause of transmission																		
		Periodic, cyclic	Background scan	Spontaneous	Initialized	Request or requested	Activation	Activation confirmation	Deactivation	Deactivation confirmation	Activation termination	Return info caused by a remote cmd	Return info caused by a local cmd	File transfer	Interrogated by group <number>	Request by group <n> counter request	unknown type identification	Unknown cause of transmission	Unknown common address of ASDU	Unknown information object address
		1	2	3	4	5	6	7	8	9	10	11	12	13	20...36	37...41	44	45	46	47
<1>	M_SP_NA_1		X	X		X						X	X		X					
<2>	M_SP_TA_1			X		X						X	X							
<3>	M_DP_NA_1		X	X		X						X	X		X					
<4>	M_DP_TA_1			X		X						X	X							
<5>	M_ST_NA_1		X	X		X						X	X		X					
<6>	M_ST_TA_1			X		X						X	X							
<7>	M_BO_NA_1		X	X		X									X					
<8>	M_BO_TA_1			X		X														
<9>	M_ME_NA_1	X	X	X		X									X					
<10>	M_ME_TA_1			X		X														
<11>	M_ME_NB_1	X	X	X		X									X					
<12>	M_ME_TB_1			X		X														
<13>	M_ME_NC_1	X	X	X		X									X					
<14>	M_ME_TC_1			X		X														
<15>	M_IT_NA_1			X												X				
<16>	M_IT_TA_1			X												X				
<30>	M_SP_TB_1			X		X						X	X							
<31>	M_DP_TB_1			X		X						X	X							
<32>	M_ST_TB_1			X		X						X	X							
<33>	M_BO_TB_1			X		X														
<34>	M_ME_TD_1			X		X														
<35>	M_ME_TE_1			X		X														
<36>	M_ME_TF_1			X		X														

Type identification		Cause of transmission														20...36	37...41	44	45	46	47
		1	2	3	4	5	6	7	8	9	10	11	12	13							
		Periodic, cyclic	Background scan	Spontaneous	Initialized	Request or requested	Activation	Activation confirmation	Deactivation	Deactivation confirmation	Activation termination	Return info caused by a remote cmd	Return info caused by a local cmd	File transfer	Interrogated by group <number>	Request by group <n> counter request	unknown type identification	Unknown cause of transmission	Unknown common address of ASDU	Unknown information object address	
<37>	M_IT_TB_1			X												X					
<45>	C_SC_NA_1						X	X	X	X	X						X	X	X	X	
<46>	C_DC_NA_1						X	X	X	X	X						X	X	X	X	
<47>	C_RC_NA_1						X	X	X	X	X						X	X	X	X	
<48>	C_SE_NA_1						X	X	X	X	X						X	X	X	X	
<49>	C_SE_NB_1						X	X	X	X	X						X	X	X	X	
<50>	C_SE_NC_1						X	X	X	X	X						X	X	X	X	
<51>	C_BO_NA_1						X	X	X	X	X						X	X	X	X	
<70>	M_EI_NA_1				X																
<100>	C_IC_NA_1						X	X	X	X	X						X	X	X	X	
<101>	C_CI_NA_1						X	X			X						X	X	X	X	
<102>	C_RD_NA_1				X												X	X	X	X	
<103>	C_CS_NA_1		X				X	X									X	X	X	X	
<104>	C_TS_NA_1						X	X									X	X	X	X	
<105>	C_RP_NA_1						X	X									X	X	X	X	
<110>	P_ME_NA_1						X	X							X		X	X	X	X	
<111>	P_ME_NB_1						X	X							X		X	X	X	X	
<112>	P_ME_NC_1						X	X							X		X	X	X	X	
<113>	P_AC_NA_1						X	X	X	X							X	X	X	X	

Basic Application Functions

Station initialization					
X	Remote initialization				
Cyclic data transmission					
X	Cyclic data transmission				
Read procedure					
X	Read procedure				
Spontaneous transmission					
X	Spontaneous transmission				
Double transmission of information objects with cause of transmission spontaneous					
-	Single-point information M_SP_NA_1, M_SP_TA_1, M_SP_TB_1 and M_PS_NA_1				
-	Double-point information M_DP_NA_1, M_DP_TA_1 and M_DP_TB_1				
-	Step position information M_ST_NA_1, M_ST_TA_1 and M_ST_TB_1				
-	Bitstring of 32 bit M_BO_NA_1, M_BO_TA_1 and M_BO_TB_1				
-	Measure value, normalized value M_ME_NA_1, M_ME_TA_1, M_ME_ND_1 and M_ME_TD_1				
-	Measure value, scaled value M_ME_NB_1, M_ME_TB_1 and M_ME_TE_1				
-	Measure value, short floating point number M_ME_NC_1, M_ME_TC_1 and M_ME_TF_1				
Station interrogation					
X	Global				
X	Group1	X	Group 7	X	Group 13
X	Group 2	X	Group 8	X	Group 14
X	Group 3	X	Group 9	X	Group 15
X	Group 4	X	Group 10	X	Group 16
X	Group 5	X	Group 11		
X	Group 6	X	Group 12	Addresses per group have to be defined	
Clock synchronization					
X	Clock synchronization				
X	Day of week used				
X	RES1, GEN (time tag substituted/ not substituted) used				
X	SU-bit (summer time) used				

Command transmission			
X	Direct command transmission	X	Select and execute command
X	Direct set point command transmission	X	Select and execute set point command
		X	C-SE-ACTTERM used
-	No additional definition)		
X	Short pulse duration (duration determined by a system parameter inn the outstation)		
X	Long pulse duration (duration determined by a system parameter inn the outstation)		
X	Persistent output		
Transmission of integrated totals			
-	Mode A: Local freeze with spontaneous		
-	Mode B: Local freeze with counter		
X	Mode C: Freeze and transmit by counter interrogation		
-	Mode D: Freeze by counter-interrogation command, frozen values reported		
X	Counter read		
X	Counter freeze with reset		
X	counter freeze without reset		
X	Counter reset		
X	General request counter		
X	Counter reset		
X	Request counter group 1		
X	Request counter group 2		
X	Request counter group 3		
X	Request counter group 4		
Parameter loading			
X	Threshold value		
-	Smoothing factor		
X	Low limit for transmission of measured value		
X	High limit for transmission of measured value		
Parameter activation			
X	Act/Deact of persistent cyclic or periodic transmission of the addressed object		
Test procedure			
X	Test procedure		

File transfer	
File transfer in monitor direction	
-	Transparent file
-	Transmission of disturbance data of protection
-	Transmission of sequences of events
-	Transmission of sequences of recorded analog value
File transfer in control direction	
-	Transparent file
Background scan	
X	Background scan
Acquisition of transmission delay	
X	Acquisition of transmission delay

IEC 60870-5-101 Interoperability for BMXNOR0200H as Slave

Introduction

The purpose of this document is to describe the specific implementation of the IEC 60870-5-101 within BMXNOR0200H as slave.

This document and the documents listed below provide detailed information on how to communicate with BMXNOR0200H as slave via the IEC 60870-5-101 protocol

- IEC 60870-5-101 = Companion standard for basic telecontrol tasks
- IEC 60870-5-5 = Basic Application Functions
- IEC 60870-5-2 = Link Transmission Procedures
- IEC 60870-5-4 = Definition and Coding of Application Information Elements
- IEC 60870-5-3 = General Structure of Application Data
- IEC 60870-5-1 = Transmission Frame Formats

Interoperability

This companion standard presents sets of parameters and alternatives from which you select subsets selected to implement particular telecontrol systems. Certain parameter values, such as the number of octets in the COMMON ADDRESS of ASDUs represent mutually exclusive alternatives. This means that only one value of the defined parameters is admitted per system. Other parameters, such as the listed set of different process information in command and in monitor direction allow the specification of the complete set or subsets, as appropriate for given applications. This Clause summarizes the parameters of the previous Clauses to facilitate a suitable selection for a specific application. If a system is composed of equipment stemming from different manufacturers, it is necessary that all partners agree on the selected parameters.

The selected parameters are marked as follows:

-	Function or ADSU is not used
X	Function or ADSU is used

System or Device

-	System definition
-	Controlling station definition (master)
X	Controlled station definition (slave)

Network Configuration

X	Point-to-point	X	Multipoint-part line
X	Multi point-to-point	X	Multipoint-star

Physical Layer

Transmission speed (control direction)					
Unbalanced interchange Circuit V.24/V.28 Standard		Unbalanced interchange Circuit V.24/V.28 Recommended if > 1200 bit/s		Balanced interchange Circuit X.24/X.27	
-	100 bit/s	X	2400 bit/s	X	2400 bit/s
-	200 bit/s	X	4800 bit/s	X	4800 bit/s
X	300 bit/s	X	9600 bit/s	X	9600 bit/s
X	600 bit/s			X	19200 bit/s
X	1200 bit/s			X	38400 bit/s
				-	56000 bit/s
				-	64000 bit/s
Transmission speed (monitor direction)					
Unbalanced interchange Circuit V.24/V.28 Standard		Unbalanced interchange Circuit V.24/V.28 Recommended if > 1200 bit/s		Balanced interchange Circuit X.24/X.27	
-	100 bit/s	X	2400 bit/s	X	2400 bit/s
-	200 bit/s	X	4800 bit/s	X	4800 bit/s
X	300 bit/s	X	9600 bit/s	X	9600 bit/s
X	600 bit/s			X	19200 bit/s
X	1200 bit/s			X	38400 bit/s
				-	56000 bit/s
				-	64000 bit/s

Link Layer

Frame format FT 1.2, single character 1 and the fixed time out interval are used exclusively in this companion standard.

When using an unbalanced link layer, the following ASDU types are returned in class 2 messages (low priority) with the indicated causes of transmission:

Link transmission procedure		Address field of link	
X	Balance transmission	X	Not present (balanced transmission only)
X	Unbalance transmission	X	One octet
		X	Two octets
		-	Structured
		-	Unstructured

Frame length		
255	Maximum frame length L (control direction)	
255	Maximum frame length L (monitor direction)	
Configurable	Time during which repetitions are permitted (Trp) or number of repetitions	
X	The standard assignment of ASDUs to class 2 messages is used as follows:	
	Type identification	Cause of transmission
	9/11/13/21	<1>
X	A special assignment of ASDUs to class 2 messages is used as follows:	
	Type identification	Cause of transmission
	1/3/5/7/9/11/13/20/21/110/111/112	<2>

Application Layer

Transmission mode for application data			
Mode 1 (least significant octet first), as defined in 4.10 of IEC 60870-5-4, is used exclusively in this companion standard			
Common address of ASDU			
X	One octet	X	Two octets
Information object address			
X	One octet	-	Structured
X	Two octets	-	Unstructured
X	Three octets		
Cause of transmission			
X	One octet	X	Two octets (with originator address). Set to zero in case of no originator address

Process information in monitor direction			
X	<1>	Single-point information	M_SP_NA_1
X	<2>	Single-point information with time tag	M_SP_TA_1
X	<3>	Double-point information	M_DP_NA_1
X	<4>	Double-point information with time tag	M_DP_TA_1
X	<5>	Step position information	M_ST_NA_1
X	<6>	Step position information with time tag	M_ST_TA_1
X	<7>	Bitstring of 32 bit	M_BO_NA_1
X	<8>	Bitstring of 32 bit with time tag	M_BO_TA_1
X	<9>	Measured value, normalized value	M_ME_NA_1

Process information in monitor direction			
X	<10>	Measured value, normalized value with time tag	M_ME_TA_1
X	<11>	Measured value, scaled value	M_ME_NB_1
X	<12>	Measured value, scaled value with time tag	M_ME_TB_1
X	<13>	Measured value, short floating point value	M_ME_NC_I
X	<14>	Measured value, short floating point value with time tag	M_ME_TC_1
X	<15>	Integrated totals	M_IT_NA_1
X	<16>	Integrated totals with time tag	M_IT_TA_1
-	<17>	Event of protection equipment with time tag	M_EP_TA_1
-	<18>	Packed start events of protection equipment with time tag	M_EP_TB_1
-	<19>	Packed output circuit information of protection equipment with time tag	M_EP_TC_1
-	<20>	Packed single-point information with status change detection	M_PS_NA_1
-	<21>	Measured value, normalized value without quality descriptor	M_ME_ND_1
X	<30>	Single-point information with time tag CP56Time2a	M_SP_TB_1
X	<31>	Double-point information with time tag CP56Time2A	M_DP_TB_1
X	<32>	Step position information with time tag CP56Time2A	M_ST_TB_1
X	<33>	Bitstring of 32 bit with time tag CP56Time2A	M_BO_TB_1
X	<34>	Measured value, normalized value with time tag CP56Time2A	M_ME_TD_1
X	<35>	Measured value, scaled value with time tag CP56Time2A	M_ME_TE_1
X	<36>	Measured value, short floating point value with time tag CP56Time2A	M_ME_TF_1
X	<37>	Integrated totals with time tag CP56Time2A	M_IT_TB_1
-	<38>	Event of protection equipment with time tag CP56Time2A	M_EP_TD_1
-	<39>	Packed start events of protection equipment with time tag CP56Time2A	M_EP_TE_1
-	<40>	Packed output circuit information of protection equipment with time tag CP56Time2a	M_EP_TF_1

Process information in control direction			
X	<45>	Single command	C_SC_NA_1
X	<46>	Double command	C_DC_NA_1
X	<47>	Regulating step command	C_RC_NA_1
X	<48>	Set point command, normalized value	C_SE_NA_1
X	<49>	Set point command, scaled value	C_SE_NB_1
X	<50>	Set point command, short floating point value	C_SE_NC_1
X	<51>	Bitstring of 32-bit	C_BO_NA_1

System information in monitor direction			
X	<70>	End of initialization	M_EI_NA_1

System information in control direction			
X	<100>	Interrogation command	C_IC_NA_1
X	<101>	Counter interrogation command	C_CI_NA_1
X	<102>	Read command	C_RD_NA_1
X	<103>	Clock synchronization command	C_CS_NA_1
X	<104>	Test command	C_TS_NB_1
X	<105>	Reset process command	C_RP_NC_1
X	<106>	Delay acquisition command	C_CD_NA_1

Parameter in control direction			
X	<110>	Parameter of measured value, normalized value	P_ME_NA_1
X	<111>	Parameter of measured value, scaled value	P_ME_NB_1
X	<112>	Parameter of measured value, short floating point value	P_ME_NC_1
X	<113>	Parameter activation	P_AC_NA_1

File transfer			
-	<120>	File ready	F_FR_NA_1
-	<121>	Section ready	F_SR_NA_1
-	<122>	Call directory, select file, call file, call section	F_SC_NA_1
-	<123>	Last section, last segment	F_LS_NA_1
-	<124>	Ack file, ack section	F_AF_NA_1
-	<125>	Segment	F_SG_NA_1
-	<126>	Directory	F_DR_TA_1

Type identification		Cause of transmission																	
		Periodic, cyclic	Background scan	Spontaneous	Initialized	Request or requested	Activation	Activation confirmation	Deactivation	Deactivation confirmation	Activation termination	Return info caused by a remote cmd	Return info caused by a local cmd	File transfer	Interrogated by group <number>	Request by group <n> counter request	unknown type identification	Unknown cause of transmission	Unknown common address of ASDU
1	2	3	4	5	6	7	8	9	10	11	12	13	20... 36	37... 41	44	45	46	47	
<1>	M_SP_NA_1	X	X		X						X	X		X					
<2>	M_SP_TA_1		X		X						X	X							
<3>	M_DP_NA_1		X	X	X						X	X		X					
<4>	M_DP_TA_1		X		X						X	X							
<5>	M_ST_NA_1	X	X		X						X	X		X					
<6>	M_ST_TA_1		X		X						X	X							
<7>	M_BO_NA_1		X	X	X									X					
<8>	M_BO_TA_1		X		X														
<9>	M_ME_NA_1	X	X	X	X									X					
<10>	M_ME_TA_1			X	X														
<11>	M_ME_NB_1	X	X	X	X									X					
<12>	M_ME_TB_1			X	X														
<13>	M_ME_NC_1	X	X	X	X									X					
<14>	M_ME_TC_1			X	X														
<15>	M_IT_NA_1		X												X				
<16>	M_IT_TA_1		X												X				
<30>	M_SP_TB_1		X		X						X	X							
<31>	M_DP_TB_1		X		X						X	X							
<32>	M_ST_TB_1		X		X						X	X							
<33>	M_BO_TB_1		X		X														
<34>	M_ME_TD_1		X		X														
<35>	M_ME_TE_1		X		X														

Type identification		Cause of transmission																			
		Periodic, cyclic	Background scan	Spontaneous	Initialized	Request or requested	Activation	Activation confirmation	Deactivation	Deactivation confirmation	Activation termination	Return info caused by a remote cmd	Return info caused by a local cmd	File transfer	Interrogated by group <number>	Request by group <n> counter request	unknown type identification	Unknown cause of transmission	Unknown common address of ASDU	Unknown information object address	
		1	2	3	4	5	6	7	8	9	10	11	12	13	20... 36	37... 41	44	45	46	47	
<36>	M_ME_TF_1			X	X																
<37>	M_IT_TB_1			X												X					
<45>	C_SC_NA_1						X	X	X	X	X						X	X	X	X	
<46>	C_DC_NA_1						X	X	X	X	X						X	X	X	X	
<47>	C_RC_NA_1						X	X	X	X	X						X	X	X	X	
<48>	C_SE_NA_1						X	X	X	X	X						X	X	X	X	
<49>	C_SE_NB_1						X	X	X	X	X						X	X	X	X	
<50>	C_SE_NC_1						X	X	X	X	X						X	X	X	X	
<51>	C_BO_NA_1						X	X	X	X	X						X	X	X	X	
<70>	M_EI_NA_1				X																
<100>	C_IC_NA_1						X	X	X	X	X						X	X	X	X	
<101>	C_CI_NA_1						X	X			X						X	X	X	X	
<102>	C_RD_NA_1					X											X	X	X	X	
<103>	C_CS_NA_1			X			X	X									X	X	X	X	
<104>	C_TS_NA_1						X	X									X	X	X	X	
<105>	C_RP_NA_1						X	X									X	X	X	X	
<106>	C_CD_NA_1			X			X	X									X	X	X	X	
<110>	P_ME_NA_1						X	X							X		X	X	X	X	
<111>	P_ME_NB_1						X	X							X		X	X	X	X	
<112>	P_ME_NC_1						X	X							X		X	X	X	X	
<113>	P_AC_NA_1						X	X	X	X							X	X	X	X	

Basic Application Functions

Station initialization	
X	Remote initialization
Cyclic data transmission	
X	Cyclic data transmission
Read procedure	
X	Read procedure
Spontaneous transmission	
X	Spontaneous transmission
Double transmission of information objects with cause of transmission spontaneous	
-	Double-point information
-	Step position information
-	Bitstring of 32 bit
-	Measure value, normalized value
-	Measure value, scaled value
-	Measure value, short floating point number

Station interrogation			
X	Global	X	Group 9
X	Group 1	X	Group 10
X	Group 2	X	Group 11
X	Group 3	X	Group 12
X	Group 4	X	Group 13
X	Group 5	X	Group 14
X	Group 6	X	Group 15
X	Group 7	X	Group 16
X	Group 8		
Clock synchronization			
X	Clock synchronization		
X	Day of week used		
X	RES1, GEN (time tag substituted/ not substituted) used		
X	SU-bit (summertime) used		
Command transmission			
X	Direct command transmission	X	Select and execute command
X	Direct set point command transmission	X	Select and execute set point command
		X	C-SE-ACTTERM used
x	No additional definition		
x	Short pulse duration (duration determined by a system parameter in the outstation)		
x	Long pulse duration (duration determined by a system parameter in the outstation)		
X	Persistent output		
Transmission of integrated totals			
X	Mode A: Local freeze with spontaneous transmission		
X	Mode B: Local freeze with counter interrogation		
X	Mode C: Freeze and transmit by counter-interrogation commands		
X	Mode D: Freeze by counter-interrogation commands, frozen values reported spontaneously		
X	Counter read		
X	Counter freeze without reset		
X	Counter freeze with reset		
X	Counter reset		
X	General request counter		
X	Request counter group 1...4		

Parameter loading	
X	Threshold value
X	Smoothing factor
-	Low limit for transmission of measured value
X	High limit for transmission of measured value
Parameter activation	
x	Act/Deact of persistent cyclic or periodic transmission of the addressed object
Test procedure	
X	Test procedure
File transfer	
File transfer in monitor direction	
-	Transparent file
-	Transmission of disturbance data of protection
-	Transmission of sequences of events
-	Transmission of sequences of recorded analog value
File transfer in control direction	
-	Transparent file
Background scan	
X	Background scan
Acquisition of transmission delay	
X	Acquisition of transmission delay

IEC 60870-5-104 Interoperability for BMXNOR0200H as Client

Introduction

The purpose of this document is to describe the specific implementation of the IEC 60870-5-104 within BMXNOR0200H as client.

This document and the documents listed below provide detailed information on how to communicate with BMXNOR0200H as client via the IEC 60870-5-104 protocol

- IEC 60870-5-104 = Companion standard for IEC 60870-5-101 over TCP/IP
- IEC 60870-5-101 = Companion standard for basic telecontrol tasks
- IEC 60870-5-101 A2 = Addendum 2 for IEC 60870-5-101
- IEC 60870-5-5 = Basic Application Functions
- IEC 60870-5-4 = Definition and Coding of Application Information Elements
- IEC 60870-5-3 = General Structure of Application Data

Interoperability

This companion standard presents sets of parameters and alternatives from which you select subsets to implement particular telecontrol systems. Certain parameter values, such as the choice of structured or unstructured fields of the INFORMATION OBJECT ADDRESS of ASDUs represent mutually exclusive alternatives. This means that only one value of the defined parameters is admitted per system. Other parameters, such as the listed set of different process information in command and in monitor direction allow the specification of the complete set or subsets, as appropriate for given applications. This clause summarizes the parameters of the previous clauses to facilitate a suitable selection for a specific application. If a system is composed of equipment stemming from different manufacturers, it is necessary that all partners agree on the selected parameters.

The interoperability list is defined as in IEC 60870-5-101 and extended with parameters used in this standard. The text descriptions of parameters which are not applicable to this companion standard are strike-through (corresponding check box is marked black).

The selected parameters are marked as follows:

-	Function or ADSU is not used
X	Function or ADSU is used

System or Device

-	System definition
X	Controlling station definition (master)
-	Controlled station definition (slave)

Application Layer

Transmission mode for application data			
Mode 1 (least significant octet first), as defined in 4.10 of IEC 60870-5-4, is used exclusively in this companion standard			
Common address of ASDU			
X	Two octets		
Information object address			
X	Three octets	X	Structured
		X	Unstructured
Cause of transmission			
X	Two octets (with originator address). Set to zero in case of no originator address		
Length of APDU			
The maximum length of APDU for both directions is 253. It is a fixed system parameter.			

Process information in monitor direction			
X	<1>	Single-point information	M_SP_NA_1
X	<3>	Double-point information	M_DP_NA_1
X	<5>	Step position information	M_ST_NA_1
X	<7>	Bit string of 32 bit	M_BO_NA_1
X	<9>	Measured value, normalized value	M_ME_NA_1
X	<11>	Measured value, scaled value	M_ME_NB_1
X	<13>	Measured value, short floating point value	M_ME_NC_I
X	<15>	Integrated totals	M_IT_NA_1
-	<20>	Packed single-point information with status change detection	M_PS_NA_1
-	<21>	Measured value, normalized value without quality descriptor	M_ME_ND_1
X	<30>	Single-point information with time tag CP56Time2a	M_SP_TB_1
X	<31>	Double-point information with time tag CP56Time2a	M_DP_TB_1
X	<32>	Step position information with time tag CP56Time2a	M_ST_TB_1
X	<33>	Bitstring of 32 bit with time tag CP56Time2a	M_BO_TB_1
X	<34>	Measured value, normalized value with time tag CP56Time2a	M_ME_TD_1
X	<35>	Measured value, scaled value with time tag CP56Time2a	M_ME_TE_1
X	<36>	Measured value, short floating point value with time tag CP56Time2A	M_ME_TF_1
X	<37>	Integrated totals with time tag CP56Time2a	M_IT_TB_1
-	<38>	Event of protection equipment with time tag CP56Time2a	M_EP_TD_1

Process information in monitor direction			
-	<39>	Packed start events of protection equipment with time tag CP56Time2a	M_EP_TE_1
-	<40>	Packed output circuit information of protection equipment with time tag CP56Time2a	M_EP_TF_1

Process information in control direction			
X	<45>	Single command	C_SC_NA_1
X	<46>	Double command	C_DC_NA_1
X	<47>	Regulating step command	C_RC_NA_1
X	<48>	Set point command, normalized value	C_SE_NA_1
X	<49>	Set point command, scaled value	C_SE_NB_1
X	<50>	Set point command, short floating point value	C_SE_NC_1
X	<51>	Bitstring of 32-bit	C_BO_NA_1
X	<58>	Single command with time tag CP56Time2a	C_SC_TA_1
X	<59>	Double command with time tag CP56Time2a	C_DC_TA_1
X	<60>	Regulating step command with time tag CP56Time2a	C_RC_TA_1
X	<61>	Setpoint command, normalized value with time tag CP56Time2a	C_SE_TA_1
X	<62>	Setpoint command, scaled value with time tag CP56Time2a	C_SE_TB_1
X	<63>	Setpoint command, short floating point value with time tag CP56Time2a	C_SE_TC_1
X	<64>	Bitstring of 32 bit with time tag CP56Time2a	C_BO_TA_1

System information in monitor direction			
X	<70>	End of initialization	M_EI_NA_1

System information in control direction			
X	<100>	Interrogation command	C_IC_NA_1
X	<101>	Counter interrogation command	C_CI_NA_1
X	<102>	Read command	C_RD_NA_1
X	<103>	Clock synchronization command	C_CS_NA_1
X	<105>	Reset process command	C_RP_NA_1
-	<107>	Test command with time tag CP56time2a	C_TS_TA_1

Parameter in control direction			
X	<110>	Parameter of measured value, normalized value	P_ME_NA_1
X	<111>	Parameter of measured value, scaled value	P_ME_NB_1
X	<112>	Parameter of measured value, short floating point value	P_ME_NC_1
X	<113>	Parameter activation	PC_AC_NA_1

File transfer			
-	<120>	File ready	F_FR_NA_1
-	<121>	Section ready	F_SR_NA_1
-	<122>	Call directory, select file, call file, call section	F_SC_NA_1
-	<123>	Last section, last segment	F_LS_NA_1
-	<124>	Ack file, ack section	F_AF_NA_1
-	<125>	Segment	F_SG_NA_1
-	<126>	Directory	F_DR_TA_1
-	<127>	Query log - Request archive file	F_SC_NB_1

Type identification		Cause of transmission																		
		Periodic, cyclic	Background scan	Spontaneous	Initialized	Request or requested	Activation	Activation confirmation	Deactivation	Deactivation confirmation	Activation termination	Return info caused by a remote cmd	Return info caused by a local cmd	File transfer	Interrogated by group <number>	Request by group <n> counter request	unknown type identification	Unknown cause of transmission	Unknown common address of ASDU	Unknown information object address
		1	2	3	4	5	6	7	8	9	10	11	12	13	20...36	37...41	44	45	46	47
<1>	M_SP_NA_1		X	X		X						X	X		X					
<3>	M_DP_NA_1		X	X		X						X	X		X					
<5>	M_ST_NA_1		X	X		X						X	X		X					
<7>	M_BO_NA_1		X	X		X									X					
<9>	M_ME_NA_1	X	X	X		X									X					
<11>	M_ME_NB_1	X	X	X		X									X					

Type identification		Cause of transmission																			
		Periodic, cyclic	Background scan	Spontaneous	Initialized	Request or requested	Activation	Activation confirmation	Deactivation	Deactivation confirmation	Activation termination	Return info caused by a remote cmd	Return info caused by a local cmd	File transfer	Interrogated by group <number>	Request by group <n> counter request	unknown type identification	Unknown cause of transmission	Unknown common address of ASDU	Unknown information object address	
		1	2	3	4	5	6	7	8	9	10	11	12	13	20...36	37...41	44	45	46	47	
<13>	M_ME_NC_1	X	X	X		X									X						
<15>	M_IT_NA_1			X												X					
<30>	M_SP_TB_1			X	X							X	X								
<31>	M_DP_TB_1			X	X							X	X								
<32>	M_ST_TB_1			X	X							X	X								
<33>	M_BO_TB_1			X	X																
<34>	M_ME_TD_1			X	X																
<35>	M_ME_TE_1			X	X																
<36>	M_ME_TF_1			X	X																
<37>	M_IT_TB_1			X												X					
<45>	C_SC_NA_1						X	X	X	X	X							X	X	X	X
<46>	C_DC_NA_1						X	X	X	X	X							X	X	X	X
<47>	C_RC_NA_1						X	X	X	X	X							X	X	X	X
<48>	C_SE_NA_1						X	X	X	X	X							X	X	X	X
<49>	C_SE_NB_1						X	X	X	X	X							X	X	X	X
<50>	C_SE_NC_1						X	X	X	X	X							X	X	X	X
<51>	C_BO_NA_1						X	X			X							X	X	X	X
<58>	C_SC_TA_1						X	X	X	X	X							X	X	X	X
<59>	C_DC_TA_1						X	X	X	X	X							X	X	X	X
<60>	C_RC_TA_1						X	X	X	X	X							X	X	X	X
<61>	C_SE_TA_1						X	X	X	X	X							X	X	X	X
<62>	C_SE_TB_1						X	X	X	X	X							X	X	X	X
<63>	C_SE_TC_1						X	X	X	X	X							X	X	X	X

Type identification		Cause of transmission																		
		Periodic, cyclic	Background scan	Spontaneous	Initialized	Request or requested	Activation	Activation confirmation	Deactivation	Deactivation confirmation	Activation termination	Return info caused by a remote cmd	Return info caused by a local cmd	File transfer	Interrogated by group <number>	Request by group <n> counter request	unknown type identification	Unknown cause of transmission	Unknown common address of ASDU	Unknown information object address
		1	2	3	4	5	6	7	8	9	10	11	12	13	20...36	37...41	44	45	46	47
<64>	C_BO_TA_1					X	X			X							X	X	X	X
<70>	M_EI_NA_1			X																
<100>	C_IC_NA_1					X	X	X	X	X							X	X	X	X
<101>	C_CI_NA_1					X	X			X							X	X	X	X
<102>	C_RD_NA_1				X												X	X	X	X
<103>	C_CS_NA_1		X			X	X										X	X	X	X
<105>	C_RP_NA_1					X	X										X	X	X	X
<110>	P_ME_NA_1					X	X								X		X	X	X	X
<111>	P_ME_NB_1					X	X								X		X	X	X	X
<112>	P_ME_NC_1					X	X								X		X	X	X	X
<113>	P_AC_NA_1					X	X	X	X								X	X	X	X

Basic Application Functions

Station initialization	
X	Remote initialization
Cyclic data transmission	
X	Cyclic data transmission
Read procedure	
X	Read procedure

Spontaneous transmission					
X	Spontaneous transmission				
Double transmission of information objects with cause of transmission spontaneous					
-	Single-point information				
-	Double-point information				
-	Step position information				
-	Bitstring of 32 bit				
-	Measure value, normalized value				
-	Measure value, scaled value				
-	Measure value, short floating point number				
Station interrogation					
X	Global				
X	Group1	X	Group 7	X	Group 13
X	Group 2	X	Group 8	X	Group 14
X	Group 3	X	Group 9	X	Group 15
X	Group 4	X	Group 10	X	Group 16
X	Group 5	X	Group 11		
X	Group 6	X	Group 12		
Clock synchronization					
X	Clock synchronization				
X	Day of week used				
X	RES1, GEN (time tag substituted/ not substituted) used				
X	SU-bit (summertime) used				
Command transmission					
X	Direct command transmission	X	Select and execute command		
X	Direct set point command transmission	X	Select and execute set point command		
		X	C-SE-ACTTERM used		
X	Short pulse duration (duration determined by a system parameter inn the outstation)				
X	Long pulse duration (duration determined by a system parameter inn the outstation)				
X	Persistent output				
X	Supervision of maximum delay in command direction of commands and set point commands				
Configurable	Maximum allowable delay of commands and set point commands				

Transmission of integrated totals	
-	Mode A: Local freeze with spontaneous transmission
-	Mode B: Local freeze with counter interrogation
X	Mode C: Freeze and transmit by counter-interrogation commands
-	Mode D: Freeze by counter-interrogation command, frozen values reported spontaneously
X	Counter read
X	Counter freeze without reset
X	Counter freeze with reset
X	Counter reset
X	General request counter
X	Request counter group 1...4
Parameter loading	
X	Threshold value
-	Smoothing factor
X	Low limit for transmission of measured values
X	High limit for transmission of measured values
Parameter activation	
X	Act/Deact of persistent cyclic or periodic transmission of the addressed object
Test procedure	
-	Test procedure
File transfer	
File transfer in monitor direction	
-	Transparent file
-	Transmission of disturbance data of protection equipment
-	Transmission of sequences of events
-	Transmission of sequences of recorded analog values
File transfer in control direction	
-	Transparent file
Background scan	
X	Background scan

Definition of time outs			
Parameters	Default Value	Remarks	Selected Value
t_1	15s	Time-out of send or test APDUs	Configurable
t_2	10s	Time-out for acknowledges in case of no data messages $t_2 < t_1$	Configurable
t_3	20s	Time-out for sending test frames in case of a long idle state	Configurable
Maximum range of values for all time outs: 1...255 s Accuracy: 1 s			
Maximum number of outstanding I format APDUs k and latest acknowledge APDUs (w)			
Parameters	Default Value	Remarks	Selected Value
k	12 APDUs	Maximum difference receive sequence number to send state variable	Configurable
w	8 APDUs	Latest acknowledge after receiving w I-format APDUs	Configurable
Maximum range of values k: 1...12 APDUs Accuracy: 1 APDU			
Maximum range of values w: 1...8 APDUs Accuracy: 1 APDU Recommendation: w should not exceed two-thirds of k			
Server Connections Support			
X	supports connection of up to 64 servers when BMX NOR works as a client.		
Portnumber			
Parameter	Value	Remarks	
Portnumber	2404	In all cases	
Redundant connections			
Configurable	Number N of redundancy group connections used		
RFC 2200 suite			
RFC 2200 is an official Internet Standard which describes the state of standardization of protocols used in the Internet as determined by the Internet Architecture Board (IAB). It offers a broad spectrum of actual standards used in the Internet. The suitable selection of documents from RFC 2200 defined in this standard for given projects has to be chosen by the user of this standard.			
X	Ethernet 802.3		
-	Serial X.21 interface		
-	Other selection from RFC 2200		

IEC 60870-5-104 Interoperability for BMXNOR0200H as Server

Introduction

The purpose of this document is to describe the specific implementation of the IEC 60870-5-104 within BMXNOR0200H as server.

This document and the documents listed below provide detailed information on how to communicate with BMXNOR0200H as server via the IEC 60870-5-104 protocol

- IEC 60870-5-104 = Companion standard for IEC 60870-5-101 over TCP/IP
- IEC 60870-5-101 = Companion standard for basic telecontrol tasks
- IEC 60870-5-101 A2 = Addendum 2 for IEC 60870-5-101
- IEC 60870-5-5 = Basic Application Functions
- IEC 60870-5-4 = Definition and Coding of Application Information Elements
- IEC 60870-5-3 = General Structure of Application Data

Interoperability

This companion standard presents sets of parameters and alternatives from which you select subsets to implement particular telecontrol systems. Certain parameter values, such as the choice of structured or unstructured fields of the INFORMATION OBJECT ADDRESS of ASDUs represent mutually exclusive alternatives. This means that only one value of the defined parameters is admitted per system. Other parameters, such as the listed set of different process information in command and in monitor direction allow the specification of the complete set or subsets, as appropriate for given applications. This Clause summarizes the parameters of the previous Clauses to facilitate a suitable selection for a specific application. If a system is composed of equipment stemming from different manufacturers, it is necessary that all partners agree on the selected parameters.

The interoperability list is defined as in IEC 60870-5-101 and extended with parameters used in this standard. The text descriptions of parameters which are not applicable to this companion standard are strike-through (corresponding check box is marked black).

The selected parameters are marked as follows:

-	Function or ASDU is not used
X	Function or ASDU is used

System or Device

-	System definition
-	Controlling station definition (master)
X	Controlled station definition (slave)

Application Layer

Transmission mode for application data			
Mode 1 (least significant octet first), as defined in 4.10 of IEC 60870-5-4, is used exclusively in this companion standard			
Common address of ASDU			
X	Two octets		
Information object address			
X	Three octets	X	Structured
		X	Unstructured
Cause of transmission			
X	Two octets (with originator address). Set to zero in case of no originator address		

Process information in monitor direction			
X	<1>	Single-point information	M_SP_NA_1
X	<3>	Double-point information	M_DP_NA_1
X	<5>	Step position information	M_ST_NA_1
X	<7>	Bitstring of 32 bit	M_BO_NA_1
X	<9>	Measured value, normalized value	M_ME_NA_1
X	<11>	Measured value, scaled value	M_ME_NB_1
X	<13>	Measured value, short floating point value	M_ME_NC_1
X	<15>	Integrated totals	M_IT_NA_1
-	<20>	Packed single-point information with status change detection	M_SP_NA_1
-	<21>	Measured value, normalized value without quality descriptor	M_ME_ND_1
X	<30>	Single-point information with time tag CP56Time2a	M_SP_TB_1
X	<31>	Double-point information with time tag CP56Time2a	M_DP_TB_1
X	<32>	Step position information with time tag CP56Time2a	M_ST_TB_1
X	<33>	Bitstring of 32 bit with time tag CP56Time2a	M_BO_TB_1
X	<34>	Measured value, normalized value with time tag CP56Time2a	M_ME_TD_1
X	<35>	Measured value, scaled value with time tag CP56Time2a	M_ME_TE_1
X	<36>	Measured value, short floating point value with time tag CP56Time2a	M_ME_TF_1
X	<37>	Integrated totals with time tag CP56Time2a	M_IT_TB_1
-	<38>	Event of protection equipment with time tag CP56Time2a	M_EP_TD_1
-	<39>	Packed start events of protection equipment with time tag CP56Time2a	M_EP_TE_1
-	<40>	Packed output circuit information of protection equipment with time tag CP56Time2a	M_EP_TF_1

Process information in control direction			
X	<45>	Single command	C_SC_NA_1
X	<46>	Double command	C_DC_NA_1
X	<47>	Regulating step command	C_RC_NA_1
X	<48>	Set point command, normalized value	C_SE_NA_1
X	<49>	Set point command, scaled value	C_SE_NB_1
X	<50>	Set point command, short floating point value	C_SE_NC_1
X	<51>	Bitstring of 32-bit	C_BO_NA_1
X	<58>	Single command with time tag CP56Time2a	C_SC_TA_1
X	<59>	Double command with time tag CP56Time2a	C_DC_TA_1
X	<60>	Regulating step command with time tag CP56Time 2a	C_RC_TA_1
X	<61>	Set point command, normalized value with time tag CP56Time2a	C_SE_TA_1
X	<62>	Set point command, scaled value with time tag CP56Time2a	C_SE_TB_1
X	<63>	Set point command, short floating point value with time tag CP56Time2a	C_SE_TC_1
X	<64>	Bitstring of 32-bit with time tag CP56Time2a	C_BO_TA_1

System information in monitor direction			
X	<70>	End of initialization	M_EI_NA_1

System information in control direction			
X	<100>	Interrogation command	C_IC_NA_1
X	<101>	Counter interrogation command	C_CI_NA_1
X	<102>	Read command	C_RD_NA_1
X	<103>	Clock synchronization command	C_CS_NA_1
X	<105>	Reset process command	C_RP_NA_1
X	<107>	Test command with time tag CP56Time2a	C_TS_TA_1

Parameter in control direction			
X	<110>	Parameter of measured value, normalized value	P_ME_NA_1
X	<111>	Parameter of measured value, scaled value	P_ME_NB_1
X	<112>	Parameter of measured value, short floating point value	P_ME_NC_1
X	<113>	Parameter activation	PC_AC_NA_1

File transfer			
-	<120>	File ready	F_FR_NA_1
-	<121>	Section ready	F_SR_NA_1
-	<122>	Call directory, select file, call file, call section	F_SC_NA_1
-	<123>	Last section, last segment	F_LS_NA_1
-	<124>	Ack file, ack section	F_AF_NA_1
-	<125>	Segment	F_SG_NA_1
-	<126>	Directory	F_DR_TA_1
-	<127>	Query log - Request archive file	F_SC_NB_1

Type identification		Cause of transmission																		
		Periodic, cyclic	Background scan	Spontaneous	Initialized	Request or requested	Activation	Activation confirmation	Deactivation	Deactivation confirmation	Activation termination	Return info caused by a remote cmd	Return info caused by a local cmd	File transfer	Interrogated by group <number>	Request by group <n> counter request	Unknown type identification	Unknown cause of transmission	Unknown common address of ASDU	Unknown information object address
		1	2	3	4	5	6	7	8	9	10	11	12	13	20...36	37...41	44	45	46	47
<1>	M_SP_NA_1		X	X		X						X	X		X					
<3>	M_DP_NA_1		X	X		X						X	X		X					
<5>	M_ST_NA_1		X	X		X						X	X		X					
<7>	M_BO_NA_1		X	X		X									X					
<9>	M_ME_NA_1	X	X	X		X									X					
<11>	M_ME_NB_1	X	X	X		X									X					
<13>	M_ME_NC_1	X	X	X		X									X					
<15>	M_IT_NA_1			X												X				
<30>	M_SP_TB_1			X		X						X	X							
<31>	M_DP_TB_1			X		X						X	X							
<32>	M_ST_TB_1			X		X						X	X							
<33>	M_BO_TB_1			X		X														

Type identification		Cause of transmission																			
		1	2	3	4	5	6	7	8	9	10	11	12	13	20...36	37...41	44	45	46	47	
		Periodic, cyclic	Background scan	Spontaneous	Initialized	Request or requested	Activation	Activation confirmation	Deactivation	Deactivation confirmation	Activation termination	Return info caused by a remote cmd	Return info caused by a local cmd	File transfer	Interrogated by group <number>	Request by group <n> counter request	Unknown type identification	Unknown cause of transmission	Unknown common address of ASDU	Unknown information object address	
<34>	M_ME_TD_1			X	X																
<35>	M_ME_TE_1			X	X																
<36>	M_ME_TF_1			X	X																
<37>	M_IT_TB_1			X												X					
<45>	C_SC_NA_1						X	X	X	X	X							X	X	X	X
<46>	C_DC_NA_1						X	X	X	X	X							X	X	X	X
<47>	C_RC_NA_1						X	X	X	X	X							X	X	X	X
<48>	C_SE_NA_1						X	X	X	X	X							X	X	X	X
<49>	C_SE_NB_1						X	X	X	X	X							X	X	X	X
<50>	C_SE_NC_1						X	X	X	X	X							X	X	X	X
<51>	C_BO_NA_1						X	X			X							X	X	X	X
<58>	C_SC_TA_1						X	X	X	X	X							X	X	X	X
<59>	C_DC_TA_1						X	X	X	X	X							X	X	X	X
<60>	C_RC_TA_1						X	X	X	X	X							X	X	X	X
<61>	C_SE_TA_1						X	X	X	X	X							X	X	X	X
<62>	C_SE_TB_1						X	X	X	X	X							X	X	X	X
<63>	C_SE_TC_1						X	X	X	X	X							X	X	X	X
<64>	C_BO_TA_1						X	X			X							X	X	X	X
<70>	M_EI_NA_1				X																
<100>	C_IC_NA_1						X	X	X	X	X							X	X	X	X
<101>	C_CI_NA_1						X	X			X							X	X	X	X
<102>	C_RD_NA_1				X													X	X	X	X
<103>	C_CS_NA_1			X			X	X										X	X	X	X

Type identification		Cause of transmission																			
		Periodic, cyclic	Background scan	Spontaneous	Initialized	Request or requested	Activation	Activation confirmation	Deactivation	Deactivation confirmation	Activation termination	Return info caused by a remote cmd	Return info caused by a local cmd	File transfer	Interrogated by group <number>	Request by group <n> counter request	Unknown type identification	Unknown cause of transmission	Unknown common address of ASDU	Unknown information object address	
		1	2	3	4	5	6	7	8	9	10	11	12	13	20...36	37...41	44	45	46	47	
<105>	C_RP_NA_1						X	X										X	X	X	X
<107>	C_TS_TA_1						X	X										X	X	X	X
<110>	P_ME_NA_1						X	X							X			X	X	X	X
<111>	P_ME_NB_1						X	X							X			X	X	X	X
<112>	P_ME_NC_1						X	X							X			X	X	X	X
<113>	P_AC_NA_1						X	X	X	X								X	X	X	X

Basic Application Functions

Station initialization	
X	Remote initialization
Cyclic data transmission	
X	Cyclic data transmission
Read procedure	
X	Read procedure
Spontaneous transmission	
X	Spontaneous transmission
Double transmission of information objects with cause of transmission spontaneous	
-	Single-point information
-	Double-point information
-	Step position information
-	Bitstring of 32 bit
-	Measure value, normalized value
-	Measure value, scaled value

-	Measure value, short floating point number				
Station interrogation					
X	Global				
X	Group1	X	Group 7	X	Group 13
X	Group 2	X	Group 8	X	Group 14
X	Group 3	X	Group 9	X	Group 15
X	Group 4	X	Group 10	X	Group 16
X	Group 5	X	Group 11		
X	Group 6	X	Group 12		
Clock synchronization					
X	Clock synchronization				
X	Day of week used				
X	RES1, GEN (time tag substituted/ not substituted) used				
X	SU-bit (summertime) used				
Command transmission					
X	Direct command transmission				
X	Direct set point command transmission				
X	Select and execute command				
X	Select and execute set point command				
X	C-SE-ACTTERM used				
X	No additional definition				
-	Short pulse duration (duration determined by a system parameter in the outstation)				
-	Long pulse duration (duration determined by a system parameter in the outstation)				
X	Persistent output				
X	Supervision of maximum delay in command direction of commands and set point commands				
Configurable	Maximum allowable delay of commands and set point commands				
Transmission of integrated totals					
X	Mode A: Local freeze with spontaneous transmission				
X	Mode B: Local freeze with counter interrogation				
X	Mode C: Freeze and transmit by counter-interrogation commands				
X	Mode D: Freeze by counter-interrogation command, frozen values reported spontaneously				
X	Counter read				
X	Counter freeze without reset				
X	Counter freeze with reset				
X	Counter reset				

X	General request counter		
X	Request counter group 1		
X	Request counter group 2		
X	Request counter group 3		
X	Request counter group 4		
Parameter loading			
X	Threshold value		
-	Smoothing factor		
X	Low limit for transmission of measured values		
X	High limit for transmission of measured values		
Parameter activation			
X	Act/Deact of persistent cyclic or periodic transmission of the addressed object		
Test procedure			
X	Test procedure		
File transfer			
File transfer in monitor direction			
-	Transparent file		
-	Transmission of disturbance data of protection equipment		
-	Transmission of sequences of events		
-	Transmission of sequences of recorded analog values		
File transfer in control direction			
-	Transparent file		
Background scan			
X	Background scan		
Definition of time-outs			
Parameter	Default Value	Remarks	Selected Value
t_1	15s	Time-out of send or test APDUs	Configurable
t_2	10s	Time-out for acknowledges in case of no data messages $t_2 < t_1$	Configurable
t_3	20s	Time-out for sending test frames in case of a long idle state	Configurable
Maximum range of values for all time outs: 1...255s, Accuracy: 1s			
Maximum number of outstanding I format APDUs k and latest acknowledge APDUs (w)			
Parameter	Default Value	Remarks	Selected Value

k	12 APDUs	Maximum difference receive sequence number to send state variable	Configurable
w	8 APDUs	Latest acknowledge after receiving w I-format APDUs	Configurable
Maximum range of values k: 1...12 APDUs Accuracy: 1 APDU			
Maximum range of values w: 1...8 APDUs Accuracy: 1 APDU Recommendation: w should not exceed two-thirds of k			
Portnumber)			
Parameter	Value	Remarks	
Portnumber	2404	In all cases	
Redundant connections			
0	Number N of redundancy group connections used		
RFC 2200 suite			
RFC 2200 is an official Internet Standard which describes the state of standardization of protocols used in the Internet as determined by the Internet Architecture Board (IAB). It offers a broad spectrum of actual standards used in the Internet. The suitable selection of documents from RFC 2200 defined in this standard for given projects has to be chosen by the user of this standard.			
X	Ethernet 802.3		
-	Serial X.21 interface		
-	Other selection from RFC 2200		

DNP3 Interoperability for BMXNOR0200H as Master

Introduction

The purpose of this information is to describe the specific implementation of the Distributed Network Protocol (DNP3) within BMXNOR0200H as master.

This information, in conjunction with the DNP3 Basic 4 Document Set, and the DNP3 Subset Definitions Document, provide detailed information on how to communicate with BMXNOR0200H as master via the DNP3 protocol.

This implementation of DNP3 is fully compliant with DNP3 Subset Definition Level 3.

DNP3 Device Profile

The following table provides a "Device Profile Document" in the standard format defined in the DNP3 Subset Definitions Document. While it is referred to in the DNP3 Subset Definitions as a "Document" it is only a component of a total interoperability guide. This table provides a complete interoperability guide for BMXNOR0200H as master:

Parameter		Description	
Vendor name: Schneider Electric			
Device name: BMXNOR0200H			
Highest DNP3 level supported:		Device function:	
For requests: Level 3		X	Master
For response: Level 3		-	Slave
Maximum data link frame size (octets):		Maximum application fragment size (octets):	
Transmitted: 292		Transmitted: 2048	
Received: 292		Received: 2048	
Maximum data link re-tries:		Maximum application layer re-tries:	
-	None	X	None
-	Fixed at	-	Configurable
X	Configurable from 0 to 65535		
Requires data link layer confirmation:			
-	Never		
-	Always		
-	Sometimes		
X	Configurable as: Never or Always		

Parameter		Description							
Requires application layer confirmation:									
X	Never								
-	Always								
-	When reporting Event Data								
-	When sending multi-fragment responses								
-	Sometimes								
-	Configurable								
Timeouts while waiting for:									
Data link confirm:	-	None	-	Fixed at	-	Variable	X	Configurable	
Complete appl. fragment:	X	None	-	Fixed at	-	Variable	-	Configurable	
Application confirm:	X	None	-	Fixed at	-	Variable	-	Configurable	
Complete appl. response:	X	None	-	Fixed at	-	Variable	-	Configurable	
Sends / Executes control operations:									
WRITE Binary outputs	-	Never	-	Always	-	Sometimes	X	Configurable	
SELECT / OPERATE	-	Never	-	Always	-	Sometimes	X	Configurable	
DIRECT OPERATE	-	Never	-	Always	-	Sometimes	X	Configurable	
DIRECT OPERATE - NO ACK	-	Never	-	Always	-	Sometimes	X	Configurable	
Count > 1	X	Never	-	Always	-	Sometimes	-	Configurable	
Pulse on	-	Never	-	Always	-	Sometimes	X	Configurable	
Pulse off	X	Never	-	Always	-	Sometimes	-	Configurable	
Latch on	-	Never	-	Always	-	Sometimes	X	Configurable	
Latch off	-	Never	-	Always	-	Sometimes	X	Configurable	
Queue	X	Never	-	Always	-	Sometimes	-	Configurable	
Clear queue	X	Never	-	Always	-	Sometimes	-	Configurable	
Expects binary input change events:									
-	Either time-tagged or non-time-tagged for a single event								
X	Both time-tagged and non tagged for single event								
-	Configurable								

Parameter	Description			
Sequential file transfer support:				
Append file modes	-	Yes	X	No
Custom status code strings	-	Yes	X	No
Permissions field	-	Yes	X	No
File events assigned to class	-	Yes	X	No
File events assigned poll specifically	-	Yes	X	No
Multiple blocks in a fragment	-	Yes	X	No
Max number of files open	0			

DNP3 Implementation Table

The following table identifies the variations, function codes, and qualifiers supported by the BMXNOR0200H as master in both request messages and in response messages.

In the following table, text in *italic and underline* indicates Subset Level 3 functionality (beyond Subset Level 2).

In the following table, text in **bold** indicates functionality beyond Subset Level 3.

Object			REQUEST (Library may send)		Function Codes (Library will Parse)	
Obj. No.	Variation No.	Description	Function Codes (dec)	Qualifier Codes (hex)	Function Codes (dec)	Qualifier Codes (hex)
1	0	Binary Input – Any Variation	1 (read)	<u>00, 01 (start-stop)</u> 06 (no range, or all)		
1	1	Binary Input	<u>1 (read)</u>	<u>00, 01 (start-stop)</u> <u>06 (no range, or all)</u>	129 (response)	00, 01 (start-stop)
1	2	Binary Input with Status	<u>1 (read)</u>	<u>00, 01 (start-stop)</u> <u>06 (no range, or all)</u>	129 (response)	00, 01 (start-stop)
2	0	Binary Input Change – Any Variation	1 (read)	06 (no range, or all) 07, 08 (limited qty)		
2	1	Binary Input Change without Time	1 (read)	06 (no range, or all) 07, 08 (limited qty)	129 (response) 130 (unsol. resp)	17, 28 (index)
2	2	Binary Input Change with Time	1 (read)	06 (no range, or all) 07, 08 (limited qty)	129 (response) 130 (unsol. resp)	17, 28 (index)

Object			REQUEST (Library may send)		Function Codes (Library will Parse)	
Obj. No.	Variation No.	Description	Function Codes (dec)	Qualifier Codes (hex)	Function Codes (dec)	Qualifier Codes (hex)
2	3	Binary Input Change with Relative Time	1 (read)	06 (no range, or all) 07, 08 (limited qty)	129 (response) 130 (unsol. resp)	17, 28 (index)
3	0	Double Bit Input – Any Variation	1 (read)	00, 01 (start-stop) 06 (no range, or all)		
3	1 (default – see note 1)	Double Bit Input	1 (read)	00, 01 (start-stop) 06 (no range, or all)	129 (response)	00, 01 (start-stop)
3	2	Double Bit Input with Status	1 (read)	00, 01 (start-stop) 06 (no range, or all)	129 (response)	00, 01 (start-stop)
4	0	Double Bit Input Change – Any Variation	1 (read)	06 (no range, or all) 07, 08 (limited qty)		
4	1	Double Bit Input Change without Time	1 (read)	06 (no range, or all) 07, 08 (limited qty)	129 (response) 130 (unsol. resp)	17, 28 (index)
4	2	Double Bit Input Change with Time	1 (read)	06 (no range, or all) 07, 08 (limited qty)	129 (response) 130 (unsol. resp)	17, 28 (index)
4	3 (default – see note 1)	Double Bit Input Change with Relative Time	1 (read)	06 (no range, or all) 07, 08 (limited qty)	129 (response) 130 (unsol. resp)	17, 28 (index)
10	0	Binary Output – Any Variation	1 (read)	<u>00, 01 (start-stop)</u> 06 (no range, or all)		
10	1	Binary Output	1 (read)	00, 01 (start-stop) 06 (no range, or all)	129 (response)	00, 01 (start-stop)
			1 (write)	00, 01 (start-stop)		
10	2	Binary Output Status	<u>1 (read)</u>	<u>00, 01 (start-stop)</u> <u>06 (no range, or all)</u>	129 (response)	00, 01 (start-stop)
11	0	Binary Output Change – Any Variation	1 (read)	06 (no range, or all) 07, 08 (limited qty)		
11	1	Binary Output Change without Time	1 (read)	06 (no range, or all) 07, 08 (limited qty)	129 (response) 130 (unsol. resp)	17, 28 (index)

Object			REQUEST (Library may send)		Function Codes (Library will Parse)	
Obj. No.	Variation No.	Description	Function Codes (dec)	Qualifier Codes (hex)	Function Codes (dec)	Qualifier Codes (hex)
11	2	Binary Output Change with Time	1 (read)	06 (no range, or all) 07, 08 (limited qty)	129 (response) 130 (unsol. resp)	17, 28 (index)
12	1	Control Relay Output Block	3(select) 4(operate) 5(direct op) 6(dir. op, noack)	17, 28 (index)	129 (response)	echo of request
20	0	Binary Counter – Any Variation	1 (read)	<u>00, 01 (start-stop)</u> 06 (no range, or all)		
			7(freeze) 8(freeze noack) 9(freeze clear) 10 (frz. cl. noack)	<u>00, 01 (start-stop)</u> 06 (no range, or all)		
20	1	32-Bit Binary Counter (with Flag)	<u>1 (read)</u>	<u>00, 01 (start-stop)</u> <u>06 (no range, or all)</u>	129 (response)	00, 01 (start-stop)
20	2	16-Bit Binary Counter (with Flag)	<u>1 (read)</u>	<u>00, 01 (start-stop)</u> <u>06 (no range, or all)</u>	129 (response)	00, 01 (start-stop)
20	5	32-Bit Binary Counter without Flag	<u>1 (read)</u>	<u>00, 01 (start-stop)</u> <u>06 (no range, or all)</u>	129 (response)	00, 01 (start-stop)
20	6	16-Bit Binary Counter without Flag	<u>1 (read)</u>	<u>00, 01 (start-stop)</u> <u>06 (no range, or all)</u>	129 (response)	00, 01 (start-stop)
21	0	Frozen Counter – Any Variation	1 (read)	<u>00, 01 (start-stop)</u> 06 (no range, or all)		
21	1	32-Bit Frozen Counter (with Flag)	<u>1 (read)</u>	<u>00, 01 (start-stop)</u> <u>06 (no range, or all)</u>	129 (response)	00, 01 (start-stop)
21	2	16-Bit Frozen Counter (with Flag)	1 (read)	00, 01 (start-stop) 06 (no range, or all)	129 (response)	00, 01 (start-stop)
21	5	32-Bit Frozen Counter with Time Of Freeze	1 (read)	00, 01 (start-stop) 06 (no range, or all)	129 (response)	00, 01 (start-stop)
21	6	16-Bit Frozen Counter with Time Of Freeze	1 (read)	00, 01 (start-stop) 06 (no range, or all)	129 (response)	00, 01 (start-stop)
21	9	32-Bit Frozen Counter without Flag	<u>1 (read)</u>	<u>00, 01 (start-stop)</u> <u>06 (no range, or all)</u>	129 (response)	00, 01 (start-stop)

Object			REQUEST (Library may send)		Function Codes (Library will Parse)	
Obj. No.	Variation No.	Description	Function Codes (dec)	Qualifier Codes (hex)	Function Codes (dec)	Qualifier Codes (hex)
21	10	16-Bit Frozen Counter without Flag	<u>1 (read)</u>	<u>00, 01 (start-stop)</u> <u>06 (no range, or all)</u>	129 (response)	00, 01 (start-stop)
22	0	Counter Change Event – Any Variation	1 (read)	06 (no range, or all) 07, 08 (limited qty)		
22	1	32-Bit Counter Change Event without Time	<u>1 (read)</u>	<u>06 (no range, or all)</u> <u>07, 08 (limited qty)</u>	129 (response) 130 (unsol. resp)	17, 28 (index)
22	2	16-Bit Counter Change Event without Time	<u>1 (read)</u>	<u>06 (no range, or all)</u> <u>07, 08 (limited qty)</u>	129 (response) 130 (unsol. resp)	17, 28 (index)
22	5	32-Bit Counter Change Event with Time	1 (read)	06 (no range, or all) 07, 08 (limited qty)	129 (response) 130 (unsol. resp)	17, 28 (index)
22	6	16-Bit Counter Change Event with Time	1 (read)	06 (no range, or all) 07, 08 (limited qty)	129 (response) 130 (unsol. resp)	17, 28 (index)
23	0	Frozen Counter Event (Variation 0 is used to request default variation)	<u>1 (read)</u>	<u>06 (no range, or all)</u> <u>07, 08 (limited qty)</u>		
23	1	32-Bit Frozen Counter Event	<u>1 (read)</u>	<u>06 (no range, or all)</u> <u>07, 08 (limited qty)</u>	<u>129 (response)</u> <u>130 (unsol. resp)</u>	<u>17, 28 (index)</u>
23	2	16-Bit Frozen Counter Event	<u>1 (read)</u>	<u>06 (no range, or all)</u> <u>07, 08 (limited qty)</u>	<u>129 (response)</u> <u>130 (unsol. resp)</u>	<u>17, 28 (index)</u>
23	5	32-Bit Frozen Counter Event with Time	1 (read)	06 (no range, or all) 07, 08 (limited qty)	129 (response) 130 (unsol. resp)	17, 28 (index)
23	6	16-Bit Frozen Counter Event with Time	1 (read)	06 (no range, or all) 07, 08 (limited qty)	129 (response) 130 (unsol. resp)	17, 28 (index)

Object			REQUEST (Library may send)		Function Codes (Library will Parse)	
Obj. No.	Variation No.	Description	Function Codes (dec)	Qualifier Codes (hex)	Function Codes (dec)	Qualifier Codes (hex)
30	0	Analog Input - Any Variation	1 (read)	<i>00, 01 (start-stop)</i> 06 (no range, or all)		
30	1	32-Bit Analog Input	<i>1 (read)</i>	<i>00, 01 (start-stop)</i> <i>06 (no range, or all)</i>	129 (response)	00, 01 (start-stop)
30	2	16-Bit Analog Input	<i>1 (read)</i>	<i>00, 01 (start-stop)</i> <i>06 (no range, or all)</i>	129 (response)	00, 01 (start-stop)
30	3	32-Bit Analog Input without Flag	<i>1 (read)</i>	<i>00, 01 (start-stop)</i> <i>06 (no range, or all)</i>	129 (response)	00, 01 (start-stop)
30	4	16-Bit Analog Input without Flag	<i>1 (read)</i>	<i>00, 01 (start-stop)</i> <i>06 (no range, or all)</i>	129 (response)	00, 01 (start-stop)
30	5	short floating point	1 (read)	00, 01 (start-stop) 06 (no range, or all)	129 (response)	00, 01 (start-stop)
32	0	Analog Change Event – Any Variation	1 (read)	06 (no range, or all) 07, 08 (limited qty)		
32	1	32-Bit Analog Change Event without Time	<i>1 (read)</i>	<i>06 (no range, or all)</i> <i>07, 08 (limited qty)</i>	129 (response) 130 (unsol. resp)	17, 28 (index)
32	2	16-Bit Analog Change Event without Time	<i>1 (read)</i>	<i>06 (no range, or all)</i> <i>07, 08 (limited qty)</i>	129 (response) 130 (unsol. resp)	17, 28 (index)
32	3	32-Bit Analog Change Event with Time	1 (read)	06 (no range, or all) 07, 08 (limited qty)	129 (response) 130 (unsol. resp)	17, 28 (index)
32	4	16-Bit Analog Change Event with Time	1 (read)	06 (no range, or all) 07, 08 (limited qty)	129 (response) 130 (unsol. resp)	17, 28 (index)
32	5	short floating point Analog Change Event without Time	1 (read)	06 (no range, or all) 07, 08 (limited qty)	129 (response) 130 (unsol. resp)	17, 28 (index)
32	7	short floating point Analog Change Event with Time	1 (read)	06 (no range, or all) 07, 08 (limited qty)	129 (response) 130 (unsol. resp)	17, 28 (index)

Object			REQUEST (Library may send)		Function Codes (Library will Parse)	
Obj. No.	Variation No.	Description	Function Codes (dec)	Qualifier Codes (hex)	Function Codes (dec)	Qualifier Codes (hex)
34	0	Analog Input Deadband (Variation 0 is used to request default variation)	1 (read)	00, 01 (start-stop) 06 (no range, or all) 07, 08 (limited qty) 17, 28 (index)		
34	1	16 bit Analog Input Deadband	1 (read) 2 (write)	00, 01 (start-stop) 06 (no range, or all) 07, 08 (limited qty) 17, 28 (index) 17, 28 (index)	129 (response)	00, 01 (start-stop) 17, 28 (index-see note 2)
34	2	32 bit Analog Input Deadband	1 (read) 2 (write)	00, 01 (start-stop) 06 (no range, or all) 07, 08 (limited qty) 17, 28 (index) 17, 28 (index)	129 (response)	00, 01 (start-stop) 17, 28 (index-see note 2)
34	3	short floating point Analog Input Deadband	1 (read) 2 (write)	00, 01 (start-stop) 06 (no range, or all) 07, 08 (limited qty) 17, 28 (index) 17, 28 (index)	129 (response)	00, 01 (start-stop) 17, 28 (index-see note 2)
40	0	Analog Output Status (Variation 0 is used to request default variation)	1 (read)	<u>00, 01 (start-stop)</u> 06 (no range, or all)		
40	1	32-Bit Analog Output Status	<u>1 (read)</u>	<u>00, 01 (start-stop)</u> <u>06 (no range, or all)</u>	<u>129 (response)</u>	<u>00, 01 (start-stop)</u>
40	2	16-Bit Analog Output Status	<u>1 (read)</u>	<u>00, 01 (start-stop)</u> <u>06 (no range, or all)</u>	129 (response)	00, 01 (start-stop)
40	3	short floating point Analog Output Status	1 (read)	00, 01 (start-stop) 06 (no range, or all)	129 (response)	00, 01 (start-stop)
40	4	short floating point Analog Output Status	1 (read)	00, 01 (start-stop) 06 (no range, or all)	129 (response)	00, 01 (start-stop)
41	1	32-Bit Analog Output Block	<u>3(select)</u> <u>4(operate)</u> <u>5(direct op)</u> <u>6(dir. op. noack)</u>	<u>17, 28 (index)</u>	<u>129 (response)</u>	<u>echo of request</u>

Object			REQUEST (Library may send)		Function Codes (Library will Parse)	
Obj. No.	Variation No.	Description	Function Codes (dec)	Qualifier Codes (hex)	Function Codes (dec)	Qualifier Codes (hex)
41	2	16-Bit Analog Output Block	3(select) 4(operate) 5(direct op) 6(dir. op, noack)	17, 28 (index)	129 (response)	echo of request
41	3	short floating point Analog Output Block	3(select) 4(operate) 5(direct op) 6(dir. op, noack)	17, 28 (index)	129 (response)	echo of request
42	1	32-Bit Analog Output Event without Time	1 (read)	06 (no range, or all) 07, 08 (limited qty)	129 (response) 130 (unsol. resp)	17, 28 (index)
42	2	16-Bit Analog Output Event without Time	1 (read)	06 (no range, or all) 07, 08 (limited qty)	129 (response) 130 (unsol. resp)	17, 28 (index)
42	3	32-Bit Analog Output Event with Time	1 (read)	06 (no range, or all) 07, 08 (limited qty)	129 (response) 130 (unsol. resp)	17, 28 (index)
42	4	16-Bit Analog Output Event with Time	1 (read)	06 (no range, or all) 07, 08 (limited qty)	129 (response) 130 (unsol. resp)	17, 28 (index)
42	5	short floating point Analog Output Event without Time	1 (read)	06 (no range, or all) 07, 08 (limited qty)	129 (response) 130 (unsol. resp)	17, 28 (index)
42	7	short floating point Analog Output Event with Time	1 (read)	06 (no range, or all) 07, 08 (limited qty)	129 (response) 130 (unsol. resp)	17, 28 (index)
50	0	Time and Date				
50	1	Time and Date	<i>1 (read)</i>	<i>07 (limited qty = 1)</i>	<i>129 (response)</i>	<i>07 (limited qty = 1)</i>
			2 (write)	07 (limited qty = 1)		
50	3	Time and Date Last Recorded Time	2 (write)	07 (limited qty)		

Object			REQUEST (Library may send)		Function Codes (Library will Parse)	
Obj. No.	Variation No.	Description	Function Codes (dec)	Qualifier Codes (hex)	Function Codes (dec)	Qualifier Codes (hex)
51	1	Time and Date CTO			129 (response) 130 (unsol. resp)	07 (limited qty) (qty = 1)
51	2	Unsynchronized Time and Date CTO			129 (response) 130 (unsol. resp)	07 (limited qty) (qty = 1)
52	1	Time Delay Coarse			129 (response)	07 (limited qty) (qty = 1)
52	2	Time Delay Fine			129 (response)	07 (limited qty) (qty = 1)
60	0	Not Defined				
60	1	Class 0 Data	1 (read)	06 (no range, or all)		
60	2	Class 1 Data	1 (read)	06 (no range, or all) 07, 08 (limited qty)		
			<u>20 (enbl. unsol.)</u> <u>21 (dsbl. unsol.)</u>	<u>06 (no range, or all)</u>		
60	3	Class 2 Data	1 (read)	06 (no range, or all) 07, 08 (limited qty)		
			<u>20 (enbl. unsol.)</u> <u>21 (dsbl. unsol.)</u>	<u>06 (no range, or all)</u>		
60	4	Class 3 Data	1 (read)	06 (no range, or all) 07, 08 (limited qty)		
			<u>20 (enbl. unsol.)</u> <u>21 (dsbl. unsol.)</u>	<u>06 (no range, or all)</u>		
80	1	Internal Indications	<u>1 (read)</u>	<u>00, 01 (start-stop)</u>	<u>129 (response)</u>	<u>00, 01 (start-stop)</u>
			2 (write) (see note 2)	00 (start-stop) index = 4 or 7		

Object			REQUEST (Library may send)		Function Codes (Library will Parse)	
Obj. No.	Variation No.	Description	Function Codes (dec)	Qualifier Codes (hex)	Function Codes (dec)	Qualifier Codes (hex)
No Object (function code only)			13 (cold restart)			
No Object (function code only)			14 (warm restart)			
No Object (function code only)			23 (delay meas.)			

NOTE: ⁽¹⁾ For static (non-change-event) objects, qualifiers 17 or 28 are only responded to when a request is sent with qualifiers 17 or 28, respectively. Otherwise, static object requests sent with qualifiers 00, 01, 06, 07, or 08, are be responded to with qualifiers 00 or 01. (For change-event objects, qualifiers 17 or 28 are always responded to.)

NOTE: ⁽²⁾ Writes of Internal Indications are only supported for indexes 4 and 7 (Restart and Need Time IIN).

DNP3 Interoperability for BMXNOR0200H as Slave

Introduction

The purpose of this information is to describe the specific implementation of the Distributed Network Protocol (DNP3) within BMXNOR0200H as slave.

This information, in conjunction with the DNP3 Basic 4 Document Set, and the DNP3 Subset Definitions Document, provide detailed information on how to communicate with BMXNOR0200H as slave via the DNP3 protocol.

This implementation of DNP3 is fully compliant with DNP3 Subset Definition Level 3.

DNP3 Device Profile

The following table provides a "Device Profile Document" in the standard format defined in the DNP3 Subset Definitions Document. While it is referred to in the DNP3 Subset Definitions as a "Document" it is only a component of a total interoperability guide. This table provides a complete interoperability guide for BMXNOR0200H as slave:

Parameter		Description	
Vendor name: Schneider Electric			
Device name: BMXNOR0200H			
Highest DNP3 level supported:		Device function:	
For requests: Level 3	-	Master	
For response: Level 3	X	Slave	
Maximum data link frame size (octets):		Maximum application fragment size (octets):	
Transmitted: 292		Transmitted: Configurable up to 2048	
Received: 292		Received: 2048	
Maximum data link re-tries:		Maximum application layer re-tries:	
-	None	X	None
-	Fixed	-	Configurable
X	Configurable from 0 to 65535		
Requires data link layer confirmation:			
-	Never		
-	Always		
-	Sometimes		
X	Configurable as: Never, Only for multi-frame messages or Always		

Parameter	Description							
Requires application layer confirmation:								
-	Never							
-	Always							
-	When reporting Event Data (Slave devices only)							
-	When sending multi-fragment responses (Slave devices only)							
-	Sometimes							
X	Configurable as: "Only when reporting event data" or "When reporting event data" or "multi-fragment messages"							
Timeouts while waiting for:								
Data link confirm:	-	None	-	Fixed at	-	Variable	X	Configurable
Complete appl. fragment:	X	None	-	Fixed at	-	Variable	-	Configurable
Application confirm:	-	None	-	Fixed at	-	Variable	X	Configurable
Complete appl. response:	X	None	-	Fixed at	-	Variable	-	Configurable
Others:	Transmission delay, configurable Select/Operate arm time out, configurable Need time interval, configurable Unsolicited notification delay, configurable Unsolicited response retry delay, configurable Unsolicited offline intercal, configurable							
Sends / Executes control operations:								
WRITE Binary outputs	X	Never	-	Always	-	Sometimes	-	Configurable
SELECT / OPERATE	-	Never	X	Always	-	Sometimes	-	Configurable
DIRECT OPERATE	-	Never	X	Always	-	Sometimes	-	Configurable
DIRECT OPERATE - NO ACK	-	Never	X	Always	-	Sometimes	-	Configurable
Count > 1	X	Never	-	Always	-	Sometimes	-	Configurable
Pulse on	-	Never	-	Always	-	Sometimes	X	Configurable
Pulse off	X	Never	-	Always	-	Sometimes	-	Configurable
Latch on	-	Never	X	Always	-	Sometimes	-	Configurable
Latch off	-	Never	X	Always	-	Sometimes	-	Configurable
Queue	X	Never	-	Always	-	Sometimes	-	Configurable
Clear queue	X	Never	-	Always	-	Sometimes	-	Configurable
Attach explanation if 'Sometimes' or 'Configurable' was checked for any operation.								
Reports Binary Input Change Events when no specific variation requested:				Reports time-tagged Binary Input Change Events when no specific variation requested:				
-	Never			-	Never			
-	Only time-tagged			-	Binary Input Change with time			
-	Only non-time-tagged			-	Binary Input Change with relative time			

Parameter		Description			
X	Configurable to send one or the other	X	Configurable		
Sends unsolicited responses:		Sends static data in unsolicited responses:			
-	Never	X	Never		
X	Configurable	-	When device restarts		
-	Only certain objects	-	When status flags change		
-	Sometimes (attach explanation)	No other options are permitted			
X	ENABLE/DISABLE UNSOLICITED function codes supported				
Default counter object/variation:		Counter roll over at:			
-	No counters reported	-	No counters reported		
X	Configurable	-	Configurable (attach explanation)		
-	Default object	-	16 Bits		
Default variation:		X	32 Bits		
-	Point-by-point list attached	-	Other value:		
		-	Point-by-point list attached		
Sends Multi-Fragment responses:					
-	Yes				
-	No				
X	Configurable				
Sequential file transfer support:					
Append file modes		-	Yes	X	No
Custom status code strings		-	Yes	X	No
Permissions field		-	Yes	X	No
File events assigned to class		-	Yes	X	No
File events send immediately		-	Yes	X	No
Multiple blocks in a fragment		-	Yes	X	No
Max number of files open		0			

DNP3 Implementation Table

The following table identifies which object variations, function codes, and qualifiers BMXNOR0200H supports in both request messages and in response messages. For static (non-change-event) objects, requests sent with qualifiers 00, 01, 06, 07, or 08, are responded to with qualifiers 00 or 01. Requests sent with qualifiers 17 or 28 are responded to with qualifiers 17 or 28. For change-event objects, qualifiers 17 or 28 are always responded to.

In the following table, text in *italic and underline* indicates Subset Level 3 functionality (beyond Subset Level 2).

In the following table, text in **bold** indicates functionality beyond Subset Level 3.

Object			REQUEST (Library may send)		Function Codes (Library will Parse)	
Obj. No.	Variation No.	Description	Function Codes (dec)	Qualifier Codes (hex)	Function Codes (dec)	Qualifier Codes (hex)
1	0	Binary Input – Any Variation	1 (read)	<u>00, 01 (start-stop)</u> 06 (no range, or all) 07, 08 (limited qty) 17, 27, 28 (index)		
1	1 (default – see note 1)	Binary Input	<u>1 (read)</u>	<u>00, 01 (start-stop)</u> <u>06 (no range, or all)</u> 07, 08 (limited qty) 17, 27, 28 (index)	129 (response)	00, 01 (start-stop) 17, 28 (index – see note 2)
1	2	Binary Input with Status	<u>1 (read)</u>	<u>00, 01 (start-stop)</u> <u>06 (no range, or all)</u> 07, 08 (limited qty) 17, 27, 28 (index)	129 (response)	00, 01 (start-stop) 17, 28 (index – see note 2)
2	0	Binary Input Change – Any Variation	1 (read)	06 (no range, or all) 07, 08 (limited qty))		
2	1	Binary Input Change without Time	1 (read)	06 (no range, or all) 07, 08 (limited qty))	129 (response) 130 (unsol. resp)	17, 28 (index)
2	2	Binary Input Change with Time	1 (read)	06 (no range, or all) 07, 08 (limited qty))	129 (response) 130 (unsol. resp)	17, 28 (index)
2	3 (default - see note 1)	Binary Input Change with Relative Time	1 (read)	06 (no range, or all) 07, 08 (limited qty))	129 (response) 130 (unsol. resp)	17, 28 (index)
3	0	Double Bit Input – Any Variation	1 (read)	00, 01 (start-stop) 06 (no range, or all) 07, 08 (limited qty) 17, 27, 28 (index)		
3	1 (default – see note 1)	Double Bit Input	1 (read)	00, 01 (start-stop) 06 (no range, or all) 07, 08 (limited qty) 17, 27, 28 (index)	129 (response)	00, 01 (start-stop) 17, 28 (index – see note 1)
3	2	Double Bit Input with Status	1 (read)	00, 01 (start-stop) 06 (no range, or all) 07, 08 (limited qty) 17, 27, 28 (index)	129 (response)	00, 01 (start-stop) 17, 28 (index – see note 1)

Object			REQUEST (Library may send)		Function Codes (Library will Parse)	
Obj. No.	Variation No.	Description	Function Codes (dec)	Qualifier Codes (hex)	Function Codes (dec)	Qualifier Codes (hex)
4	0	Double Bit Input Change – Any Variation	1 (read)	06 (no range, or all) 07, 08 (limited qty)		
4	1	Double Bit Input Change without Time	1 (read)	06 (no range, or all) 07, 08 (limited qty)	129 (response) 130 (unsol. resp)	17, 28 (index)
4	2	Double Bit Input Change with Time	1 (read)	06 (no range, or all) 07, 08 (limited qty)	129 (response) 130 (unsol. resp)	17, 28 (index)
4	3 (default – see note 1)	Double Bit Input Change with Relative Time	1 (read)	06 (no range, or all) 07, 08 (limited qty)	129 (response) 130 (unsol. resp)	17, 28 (index)
10	0	Binary Output – Any Variation	1 (read)	<u>00, 01 (start-stop)</u> 06 (no range, or all) 07, 08 (limited qty) 17, 27, 28 (index)		
10	1	Binary Output	1 (read)	00, 01 (start-stop) 06 (no range, or all) 07, 08 (limited qty) 17, 27, 28 (index)	129 (response)	00, 01 (start-stop) 17, 28 (index – see note 1)
			1 (read)	00, 01 (start-stop)		
10	2 (default – see note 1)	Binary Output Status	<u>1 (read)</u>	<u>00, 01 (start-stop)</u> <u>06 (no range, or all)</u> 07, 08 (limited qty) 17, 27, 28 (index)	129 (response)	00, 01 (start-stop) 17, 28 (index – see note 2)
11	0	Binary Output Change – Any Variation	1 (read)	06 (no range, or all) 07, 08 (limited qty)		
11	1 (default – see note 1)	Binary Output Change without Time	1 (read)	06 (no range, or all) 07, 08 (limited qty)	129 (response) 130 (unsol. resp)	17, 28 (index)
11	2	Binary Output Change with Time	1 (read)	06 (no range, or all) 07, 08 (limited qty)	129 (response) 130 (unsol. resp)	17, 28 (index)

Object			REQUEST (Library may send)		Function Codes (Library will Parse)	
Obj. No.	Variation No.	Description	Function Codes (dec)	Qualifier Codes (hex)	Function Codes (dec)	Qualifier Codes (hex)
12	1	Control Relay Output Block	3 (select) 4 (operate) 5 (direct op.) 6 (dir. op, noack)	17, 28 (index)	129 (response)	echo of request
12	2	Pattern Control Block	3 (select) 4 (operate) <u>5 (direct op.)</u> <u>6 (dir. op. noack)</u>	<u>7 (limited quantity)</u>	129 (response)	echo of request
12	3	Pattern Mask	3 (select) 4 (operate) <u>5 (direct op.)</u> <u>6 (dir. op. noack)</u>	<u>00, 01 (start-stop)</u>	129 (response)	echo of request
20	0	Binary Counter – Any Variation	1 (read)	<u>00, 01 (start-stop)</u> 06 (no range, or all) 07, 08 (limited qty) 17, 27, 28 (index)		
			7 (freeze) 8 (freeze noack) 9 (freeze clear) 10 (frz. cl. noack)	<u>00, 01 (start-stop)</u> 06 (no range, or all) 07, 08 (limited qty)		
20	1	32-Bit Binary Counter (with Flag)	<u>1 (read)</u>	<u>00, 01 (start-stop)</u> <u>06 (no range, or all)</u> 07, 08 (limited qty) 17, 27, 28 (index)	129 (response)	00, 01 (start-stop) 17, 28 (index – see note 2)
20	2	16-Bit Binary Counter (with Flag)	<u>1 (read)</u>	<u>00, 01 (start-stop)</u> <u>06 (no range, or all)</u> 07, 08 (limited qty) 17, 27, 28 (index)	129 (response)	00, 01 (start-stop) 17, 28 (index – see note 2)
20	5 (default - see note 1)	32-Bit Binary Counter without Flag	<u>1 (read)</u>	<u>00, 01 (start-stop)</u> <u>06 (no range, or all)</u> 07, 08 (limited qty) 17, 27, 28 (index)	129 (response)	00, 01 (start-stop) 17, 28 (index – see note 2)
20	6	16-Bit Binary Counter without Flag	<u>1 (read)</u>	<u>00, 01 (start-stop)</u> <u>06 (no range, or all)</u> 07, 08 (limited qty) 17, 27, 28 (index)	129 (response)	00, 01 (start-stop) 17, 28 (index – see note 2)

Object			REQUEST (Library may send)		Function Codes (Library will Parse)	
Obj. No.	Variation No.	Description	Function Codes (dec)	Qualifier Codes (hex)	Function Codes (dec)	Qualifier Codes (hex)
21	0	Frozen Counter – Any Variation	1 (read)	<u>00, 01 (start-stop)</u> 06 (no range, or all) 07, 08 (limited qty) 17, 27, 28 (index)		
21	1	32-Bit Frozen Counter (with Flag)	<u>1 (read)</u>	<u>00, 01 (start-stop)</u> <u>06 (no range, or all)</u> 07, 08 (limited qty) 17, 27, 28 (index)	129 (response)	00, 01 (start-stop) 17, 28 (index – see note 2)
21	2	16-Bit Frozen Counter (with Flag)	<u>1 (read)</u>	<u>00, 01 (start-stop)</u> <u>06 (no range, or all)</u> 07, 08 (limited qty) 17, 27, 28 (index)	129 (response)	00, 01 (start-stop) 17, 28 (index – see note 2)
21	5	32-Bit Frozen Counter with Time Of Freeze	1 (read)	00, 01 (start-stop) 06 (no range, or all) 07, 08 (limited qty) 17, 27, 28 (index)	129 (response)	00, 01 (start-stop) 17, 28 (index – see note 1)
21	6	16-Bit Frozen Counter with Time Of Freeze	1 (read)	00, 01 (start-stop) 06 (no range, or all) 07, 08 (limited qty) 17, 27, 28 (index)	129 (response)	00, 01 (start-stop) 17, 28 (index – see note 1)
21	9 (default – see note 1)	32-Bit Frozen Counter without Flag	<u>1 (read)</u>	<u>00, 01 (start-stop)</u> <u>06 (no range, or all)</u> 07, 08 (limited qty) 17, 27, 28 (index)	129 (response)	00, 01 (start-stop) 17, 28 (index – see note 2)
21	10	16-Bit Frozen Counter without Flag	<u>1 (read)</u>	<u>00, 01 (start-stop)</u> <u>06 (no range, or all)</u> 07, 08 (limited qty) 17, 27, 28 (index)	129 (response)	00, 01 (start-stop) 17, 28 (index – see note 2)
22	0	Counter Change Event – Any Variation	1 (read)	06 (no range, or all) 07, 08 (limited qty)		
22	1 (default – see note 1)	32-Bit Counter Change Event without Time	<u>1 (read)</u>	<u>06 (no range, or all) 07, 08 (limited qty)</u>	129 (response) 130 (unsol. resp)	17, 28 (index)
22	2	16-Bit Counter Change Event without Time	<u>1 (read)</u>	<u>06 (no range, or all) 07, 08 (limited qty)</u>	129 (response) 130 (unsol. resp)	17, 28 (index)

Object			REQUEST (Library may send)		Function Codes (Library will Parse)	
Obj. No.	Variation No.	Description	Function Codes (dec)	Qualifier Codes (hex)	Function Codes (dec)	Qualifier Codes (hex)
22	5	32-Bit Counter Change Event with Time	1 (read)	06 (no range, or all) 07, 08 (limited qty)	129 (response) 130 (unsol. resp)	17, 28 (index)
22	6	16-Bit Counter Change Event with Time	1 (read)	06 (no range, or all) 07, 08 (limited qty)	129 (response) 130 (unsol. resp)	17, 28 (index)
23	0	Frozen Counter Event (Variation 0 is used to request default variation)	<u>1 (read)</u>	<u>06 (no range, or all) 07, 08 (limited qty)</u>		
23	1 (default – see note 1)	32-Bit Frozen Counter Event	<u>1 (read)</u>	<u>06 (no range, or all) 07, 08 (limited qty)</u>	<u>129 (response) 130 (unsol. resp)</u>	<u>17, 28 (index)</u>
23	2	16-Bit Frozen Counter Event	<u>1 (read)</u>	<u>06 (no range, or all) 07, 08 (limited qty)</u>	<u>129 (response) 130 (unsol. resp)</u>	<u>17, 28 (index)</u>
23	5	32-Bit Frozen Counter Event with Time	1 (read)	06 (no range, or all) 07, 08 (limited qty)	129 (response) 130 (unsol. resp)	17, 28 (index)
23	6	16-Bit Frozen Counter Event with Time	1 (read)	06 (no range, or all) 07, 08 (limited qty)	129 (response) 130 (unsol. resp)	17, 28 (index)
30	0	Analog Input - Any Variation	1 (read)	<u>00, 01 (start-stop)</u> 06 (no range, or all) 07, 08 (limited qty) 17, 27, 28 (index)		
30	1	32-Bit Analog Input	<u>1 (read)</u>	<u>00, 01 (start-stop)</u> <u>06 (no range, or all)</u> 07, 08 (limited qty) 17, 27, 28 (index)	129 (response)	00, 01 (start-stop) 17, 28 (index – see note 2)
30	2	16-Bit Analog Input	<u>1 (read)</u>	<u>00, 01 (start-stop)</u> <u>06 (no range, or all)</u> 07, 08 (limited qty) 17, 27, 28 (index)	129 (response)	00, 01 (start-stop) 17, 28 (index – see note 2)

Object			REQUEST (Library may send)		Function Codes (Library will Parse)	
Obj. No.	Variation No.	Description	Function Codes (dec)	Qualifier Codes (hex)	Function Codes (dec)	Qualifier Codes (hex)
30	3(default–see note 1)	32-Bit Analog Input without Flag	<u>1 (read)</u>	<u>00, 01 (start-stop)</u> <u>06 (no range, or all)</u> 07, 08 (limited qty) 17, 27, 28 (index)	129 (response)	00, 01 (start-stop) 17, 28 (index – see note 2)
30	4	16-Bit Analog Input without Flag	<u>1 (read)</u>	<u>00, 01 (start-stop)</u> <u>06 (no range, or all)</u> 07, 08 (limited qty) 17, 27, 28 (index)	129 (response)	00, 01 (start-stop) 17, 28 (index – see note 2)
30	5	short floating point	1 (read)	00, 01 (start-stop) 06 (no range, or all) 07, 08 (limited qty) 17, 27, 28 (index)	129 (response)	00, 01 (start-stop) 17, 28 (index – see note 2)
32	0	Analog Change Event – Any Variation	1 (read)	06 (no range, or all) 07, 08 (limited qty)		
32	1(default–see note 1)	32-Bit Analog Change Event without Time	<u>1 (read)</u>	<u>06 (no range, or all) 07,</u> <u>08 (limited qty)</u>	129 (response) 130 (unsol. resp)	17, 28 (index)
32	2	16-Bit Analog Change Event without Time	<u>1 (read)</u>	<u>06 (no range, or all) 07,</u> <u>08 (limited qty)</u>	129 (response) 130 (unsol. resp)	17, 28 (index)
32	3	32-Bit Analog Change Event with Time	1 (read)	06 (no range, or all) 07, 08 (limited qty)	129 (response) 130 (unsol. resp)	17, 28 (index)
32	4	16-Bit Analog Change Event with Time	1 (read)	06 (no range, or all) 07, 08 (limited qty)	129 (response) 130 (unsol. resp)	17, 28 (index)
32	5	short floating point Analog Change Event without Time	1 (read)	06 (no range, or all) 07, 08 (limited qty)	129 (response) 130 (unsol. resp)	17, 28 (index)
32	7	short floating point Analog Change Event with Time	1 (read)	06 (no range, or all) 07, 08 (limited qty)	129 (response) 130 (unsol. resp)	17, 28 (index)

Object			REQUEST (Library may send)		Function Codes (Library will Parse)	
Obj. No.	Variation No.	Description	Function Codes (dec)	Qualifier Codes (hex)	Function Codes (dec)	Qualifier Codes (hex)
34	0	Analog Input Deadband (Variation 0 is used to request default variation)	1 (read)	00, 01 (start-stop) 06 (no range, or all) 07, 08 (limited qty) 17, 28 (index)		
34	1	16 bit Analog Input Deadband	1 (read) 2 (write)	00, 01 (start-stop) 06 (no range, or all) 07, 08 (limited qty) 17, 28 (index) 17, 28 (index)	129 (response)	00, 01 (start-stop) 17, 28 (index-see note 2)
34	2	32 bit Analog Input Deadband	1 (read) 2 (write)	00, 01 (start-stop) 06 (no range, or all) 07, 08 (limited qty) 17, 28 (index) 17, 28 (index)	129 (response)	00, 01 (start-stop) 17, 28 (index-see note 2)
34	3	short floating point Analog Input Deadband	1 (read) 2 (write)	00, 01 (start-stop) 06 (no range, or all) 07, 08 (limited qty) 17, 28 (index) 17, 28 (index)	129 (response)	00, 01 (start-stop) 17, 28 (index-see note 2)
40	0	Analog Output Status	1 (read)	<u>00, 01 (start-stop)</u> 06 (no range, or all) 07, 08 (limited qty) 17, 27, 28 (index)		
40	1	32-Bit Analog Output Status	<u>1 (read)</u>	<u>00, 01 (start-stop)</u> <u>06 (no range, or all)</u> 07, 08 (limited qty) 17, 27, 28 (index)	<u>129 (response)</u>	<u>00, 01 (start-stop)</u> 17, 28 (index – see note 2)
40	2(default – see note 1)	16-Bit Analog Output Status	<u>1 (read)</u>	<u>00, 01 (start-stop)</u> <u>06 (no range, or all)</u> 07, 08 (limited qty) 17, 27, 28 (index)	129 (response)	00, 01 (start-stop) 17, 28 (index – see note 2)
40	3	short floating point Analog Output Status	1 (read)	00, 01 (start-stop) 06 (no range, or all) 07, 08 (limited qty) 17, 27, 28 (index)	129 (response)	00, 01 (start-stop) 17, 28 (index – see note 2)
41	0	Analog Output Block		00, 01 (start-stop) 06 (no range, or all) 07, 08 (limited qty) 17, 27, 28 (index)		

Object			REQUEST (Library may send)		Function Codes (Library will Parse)	
Obj. No.	Variation No.	Description	Function Codes (dec)	Qualifier Codes (hex)	Function Codes (dec)	Qualifier Codes (hex)
41	1	32-Bit Analog Output Block	<i>3 (select) 4 (operate) 5 (direct op) 6 (dir. op. noack)</i>	<i>17, 28 (index) 27 (index)</i>	<i>129 (response)</i>	<i>echo of request</i>
41	2	16-Bit Analog Output Block	3 (select) 4 (operate) 5 (direct op) 6 (dir. op. noack)	17, 28 (index) 27 (index)	129 (response)	echo of request
41	3	short floating point Analog Output Block	3 (select) 4 (operate) 5 (direct op) 6 (dir. op. noack)	17, 27, 28 (index)	129 (response)	echo of request
42	0	Analog Output Event – Any Variation	1 (read)	06 (no range, or all) 07, 08 (limited qty)		
42	1	32-Bit Analog Output Event without Time	1 (read)	06 (no range, or all) 07, 08 (limited qty)	129 (response) 130 (unsol. resp)	17, 28 (index)
42	2(default – see note 1)	16-Bit Analog Output Event without Time	1 (read)	06 (no range, or all) 07, 08 (limited qty)	129 (response) 130 (unsol. resp)	17, 28 (index)
42	3	32-Bit Analog Output Event with Time	1 (read)	06 (no range, or all) 07, 08 (limited qty)	129 (response) 130 (unsol. resp)	17, 28 (index)
42	4	16-Bit Analog Output Event with Time	1 (read)	06 (no range, or all) 07, 08 (limited qty)	129 (response) 130 (unsol. resp)	17, 28 (index)
42	5	short floating point Analog Output Event without Time	1 (read)	06 (no range, or all) 07, 08 (limited qty)	129 (response) 130 (unsol. resp)	17, 28 (index)

Object			REQUEST (Library may send)		Function Codes (Library will Parse)	
Obj. No.	Variation No.	Description	Function Codes (dec)	Qualifier Codes (hex)	Function Codes (dec)	Qualifier Codes (hex)
42	7	short floating point Analog Output Event with Time	1 (read)	06 (no range, or all) 07, 08 (limited qty)	129 (response) 130 (unsol. resp)	17, 28 (index)
50	0	Time and Date				
50	1 (default – see note 1)	Time and Date	<i>1 (read)</i>	<i>07 (limited qty = 1)</i>	<i>129 (response)</i>	<i>07 (limited qty = 1)</i>
			2 (write)	07 (limited qty = 1)		
50	3	Time and Date Last Recorded Time	2 (write)	07 (limited qty)		
51	1	Time and Date CTO			129 (response) 130 (unsol. resp)	07 (limited qty) (qty = 1)
51	2	Unsynchronized Time and Date CTO			129 (response) 130 (unsol. resp)	07 (limited qty)(qty = 1)
52	1	Time Delay Coarse			129 (response)	07 (limited qty)(qty = 1)
52	2	Time Delay Fine			129 (response)	07 (limited qty)(qty = 1)
60	0	Not Defined				
60	1	Class 0 Data	1 (read)	06 (no range, or all)		
60	2	Class 1 Data	1 (read)	06 (no range, or all) 07, 08 (limited qty)		
			<i>20 (enbl. unsol.) 21 (dab. unsol.) 22 (assign class)</i>	<i>06 (no range, or all)</i>		

Object			REQUEST (Library may send)		Function Codes (Library will Parse)	
Obj. No.	Variation No.	Description	Function Codes (dec)	Qualifier Codes (hex)	Function Codes (dec)	Qualifier Codes (hex)
60	3	Class 2 Data	1 (read)	06 (no range, or all) 07, 08 (limited qty)		
			<u>20 (enbl. unsol.)</u> <u>21 (dab. unsol.)</u> <u>22 (assign class)</u>	<u>06 (no range, or all)</u>		
60	4	Class 3 Data	1 (read)	06 (no range, or all) 07, 08 (limited qty)		
			<u>20 (enbl. unsol.)</u> <u>21 (dab. unsol.)</u> <u>22 (assign class)</u>	<u>06 (no range, or all)</u>		
80	1	Internal Indications	<u>1 (read)</u>	<u>00, 01 (start-stop)</u>	<u>129 (response)</u>	<u>00, 01 (start-stop)</u>
			2 (write) (see note 3)	00 (start-stop) index=4 or 7		
No Object (function code only)			13 (cold restart)			
No Object (function code only)			14 (warm restart)			
No Object (function code only)			23 (delay meas.)			
No Object (function code only)			24(record current time)			

NOTE: ⁽¹⁾ A Default variation refers to the variation responded to when variation 0 is requested and/or in class 0, 1, 2, or 3 scans. Default variations are configurable; however, default settings for the configuration parameters are indicated in the table above.

NOTE: ⁽²⁾ For static (non-change-event) objects, qualifiers 17 or 28 are only responded to when a request is sent with qualifiers 17 or 28, respectively. Otherwise, static object requests sent with qualifiers 00, 01, 06, 07, or 08, are responded to with qualifiers 00 or 01. (For change-event objects, qualifiers 17 or 28 are always responded to.)

NOTE: ⁽³⁾ Writes of Internal Indications are only supported for indexes 4 and 7 (Need Time IIN1-4 or Restart IIN1-7).

Appendix B

Ethernet Language Objects

About this Chapter

This chapter describes the language objects associated with the Ethernet communication modules.

There is also a discussion of IODDTs. The IODDT (Input/Output Derived Data Type) is a data type associated with a PLC channel or module. Expert modules are associated with specific IODDTs.

What Is in This Chapter?

This chapter contains the following sections:

Section	Topic	Page
B.1	Language Objects and IODDTs of Ethernet Communication	396
B.2	Exchange Objects of Type T_COM_ETH_BMX	401
B.3	Language Objects Associated with BMXNOR0200H Module Configuration	405

Section B.1

Language Objects and IODDTs of Ethernet Communication

About this Section

This section provides a general overview of language objects and IODDTs of Ethernet communication.

What Is in This Section?

This section contains the following topics:

Topic	Page
Language Objects and IODDTs of Ethernet Communication	397
Implicit Exchange Language Objects Associated with the Application-Specific Function	398
Explicit Exchange Language Objects Associated with the Application-Specific Function	399

Language Objects and IODDTs of Ethernet Communication

General

Ethernet communication has the following IODDT:

- `T_COM_ETH_BMX`: specific to modules with Ethernet communication

IODDTs are predefined by the manufacturer and contain input/output language objects belonging to the channel of an application-specific module.

NOTE:

IODDT variables can be created with:

- the I/O objects tab
- the Data Editor

Types of Language Objects

Each IODDT has a set of language objects that is used to control and check the operation of the IODDT. There are two types of language objects:

- **implicit**: Implicit exchange objects are exchanged automatically on each cycle turn of the task associated with the module. These exchanges concern the states of modules, communication signals, slaves, etc.
- **explicit**: Explicit exchange objects are exchanged at the request of the application, using explicit exchange instructions. These exchanges set parameters and diagnose the module.

Elsewhere in this guide are detailed descriptions for the IODDT types (*see Modicon M340 for Ethernet, Communications Modules and Processors, User Manual*).

Implicit Exchange Language Objects Associated with the Application-Specific Function

At a Glance

An integrated application-specific interface or the addition of a module automatically enhances the language objects application used to program this interface or module.

These objects correspond to the input/output images and software data of the module or integrated application-specific interface.

Reminders

The module inputs (%I and %IW) are updated in the PLC memory at the start of the task, the PLC being in RUN or STOP mode.

The outputs (%Q and %QW) are updated at the end of the task, only when the PLC is in RUN mode.

NOTE: When the task occurs in STOP mode, either of the following are possible, depending on the configuration selected:

- outputs are set to fallback position (fallback mode)
- outputs are maintained at their last value (maintain mode)

Figure

The following diagram shows the operating cycle of a PLC task (cyclical execution).

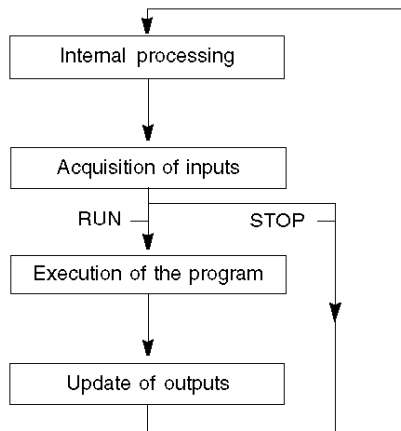

Explicit Exchange Language Objects Associated with the Application-Specific Function

Introduction

Explicit exchanges are performed at the user program's request using these instructions:

- READ_STS (read status words)
- WRITE_CMD (write command words)
- WRITE_PARAM (write adjustment parameters)
- READ_PARAM (read adjustment parameters)
- SAVE_PARAM (save adjustment parameters)
- RESTORE_PARAM (restore adjustment parameters)

For more details about instructions, refer to *EcoStruxure™ Control Expert, I/O Management, Block Library*.

These exchanges apply to a set of %MW objects of the same type (status, commands or parameters) that belong to a channel.

These objects can:

- provide information about the module (for example, type of error detected in a channel)
- have command control of the module (for example, switch command)
- define the module's operating modes (save and restore adjustment parameters in the process of application)

NOTE: To avoid several simultaneous explicit exchanges for the same channel, it is necessary to test the value of the word EXCH_STS (%MW_{r.m.c.0}) of the IODDT associated to the channel before calling any EF addressing this channel.

NOTE: Explicit exchanges are not supported when X80 analog and digital I/O modules are configured through an eX80 adapter module (BMECRA31210) in a Quantum EIO configuration. You cannot set up a module's parameters from the PLC application during operation.

General Principle for Using Explicit Instructions

The diagram below shows the different types of explicit exchanges that can be made between the application and module.

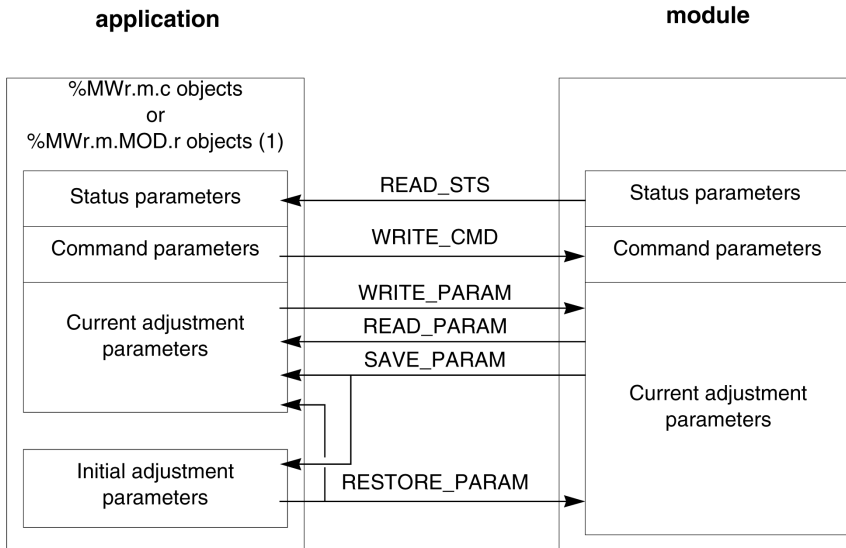

(1) Only with READ_STS and WRITE_CMD instructions.

Managing Exchanges

During an explicit exchange, check performance to see that the data is only taken into account when the exchange has been correctly executed.

To do this, two types of information is available:

- information concerning the exchange in progress (see *EcoStruxure™ Control Expert, I/O Management, Block Library*)
- the exchange report (see *EcoStruxure™ Control Expert, I/O Management, Block Library*)

The following diagram describes the management principle for an exchange.

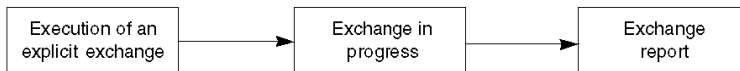

NOTE: In order to avoid several simultaneous explicit exchanges for the same channel, it is necessary to test the value of the word EXCH_STS (%MWr.m.c.0) of the IODDT associated to the channel before calling any EF addressing this channel.

Section B.2

Exchange Objects of Type T_COM_ETH_BMX

About this Section

The section describes the implicit and explicit exchange objects of type T_COM_ETH_BMX.

What Is in This Section?

This section contains the following topics:

Topic	Page
Details of Implicit Exchange Objects of the IODDT Type T_COM_ETH_BMX	402
Details of Explicit Exchange Objects of the IODDT Type T_COM_ETH_BMX	403

Details of Implicit Exchange Objects of the IODDT Type T_COM_ETH_BMX

Objects

The IODDT of type T_COM_ETH_BMX has implicit exchange objects, which are described below. This type of IODDT applies to the BMXNOR0200H module:

Standard Symbol		Type	Meaning	Address
CH_ERROR		BOOL	the bit is set to indicate that a line error has been detected	%IWr.m.c.ERR
SERVICES_STS		INT	status of the different services	%IWr.m.c.0
	P502_STATUS_BIT	BOOL	Port 502 messaging service status (0=OK, 1=NOK)	%IWr.m.c.0.0
	IOS_STATUS_BIT	BOOL	reserved	%IWr.m.c.0.1
	GLBD_STATUS_BIT	BOOL	reserved	%IWr.m.c.0.2
	EMAIL_STATUS_BIT	BOOL	e-mail service status (0=OK, 1=NOK)	%IWr.m.c.0.3
	FDRS_STATUS_BIT	BOOL	reserved	%IWr.m.c.0.4
	NTPC_STATUS_BIT	BOOL	NTP Client service status (0=OK, 1=NOK)	%IWr.m.c.0.5
	TCPOPEN_STATUS_BIT	BOOL	Reserved for L2 (for future use)	%IWr.m.c.0.6
NOTE: All objects are read only.				

Details of Explicit Exchange Objects of the IODDT Type T_COM_ETH_BMX

System Words

The table below shows the meaning of the system word bits:

Standard Symbol	Type	Access	Meaning	Address
EXCH_STS	INT	R	exchange status	%MWr.m.c.0
STS_IN_PROGR	BOOL	R	reading of status words of the channel in progress	%MWr.m.c.0.0
CMD_IN_PROGR	BOOL	R	command parameter write in progress	%MWr.m.c.0.1
ADJ_IN_PROGR	BOOL	R	adjust parameter exchange in progress	%MWr.m.c.0.2
RECONF_IN_PROGR	BOOL	R	reconfiguration in progress	%MWr.m.c.0.15
EXCH_RPT	INT	R	channel report	%MWr.m.c.1
STS_ERR	BOOL	R	channel status cannot be read	%MWr.m.c.1.0
CMD_ERR	BOOL	R	a command cannot be sent on the channel	%MWr.m.c.1.1
ADJ_ERR	BOOL	R	the channel cannot be adjusted	%MWr.m.c.1.2
RECONF_ERR	BOOL	R	the channel cannot be reconfigured	%MWr.m.c.1.15
R = read only				

Status Words

The table below gives the meanings of the status word bits CH_FLT (%MWr.m.c.2). The reading is taken by a READ_STS:

Standard Symbol	Type	Access	Meaning	Address
INTERNAL_FLT	BOOL	R	an internal error has been detected or the self-test cannot be completed	%MWr.m.c.2.4
APPLI_FLT	BOOL	R	an adjustment or configuration error has been detected	%MWr.m.c.2.7
R = read only				

The table below shows the result of a READ_STS call:

Standard Symbol	Type	Access	Meaning	Address
ETH_STATUS	INT	R	Ethernet port global status	%MWr.m.c.3
IP_ADDR	DINT	R	IP address	%MDr.m.c.4
P502_NB_CONN_DENIED	INT	R	number of denied Port 502 connections	%MWr.m.c.6
BW_MAX_MSG_IN	INT	R	maximum number of received messages on the Ethernet port per second	%MWr.m.c.10
BW_MAX_MSG_BC	INT	R	maximum number of broadcast messages received per second	%MWr.m.c.14
reserved	INT	R	reserved for future use	%MWr.m.c.15
R = read only				

Command Words

This table shows the available command words:

Standard Symbol	Type	Access	Meaning	Address
ETH_RESET	BOOL	W	Ethernet component reset	%MWr.m.c.16.0
BW_CNT_RESET	BOOL	W	max. message counters reset	%MWr.m.c.16.1
P502_CNT_RESET	BOOL	W	messaging counters reset	%MWr.m.c.16.2
W = write only				

The command is carried out with the WRITE_CMD (IODDT_VAR1) function.

Section B.3

Language Objects Associated with BMXNOR0200H Module Configuration

About this Section

This section describes the configuration language objects associated with the Ethernet communication on the BMXNOR0200H module.

What Is in This Section?

This section contains the following topics:

Topic	Page
Language Objects for Implicit Exchange	406
Language Objects for Explicit Exchange	407

Language Objects for Implicit Exchange

Introduction

This topic describes the implicit exchange language objects for the BMXNOR0200H module.

Input Bits

The following table describes the input bit (%I) language objects:

Object	Description
%Ir.m.0.ERR	the CH_ERROR bit

Input Words

The following table describes the input word (%IW) language objects:

Object	Description
%IW.r.m.0.0	status of Ethernet services: <ul style="list-style-type: none">● bit 0: port 502 messaging service status (0=OK, 1=NOK)● bit 1: reserved● bit 2: reserved● bit 3: e-mail service status (0=OK, 1=NOK)● bit 4: reserved● bit 5:<ul style="list-style-type: none">○ BMX NOR 0200: reserved for future use○ BMX P34 20•0: reserved for compatibility with the BMX NOR 0200● bit 6: reserved for future use● bit 7: reserved
%IW.r.m.0.1...%IW.r.m.0.4	reserved
%IW.r.m.0.5...%IW.r.m.0.8	reserved

Language Objects for Explicit Exchange

Introduction

This topic describes the explicit exchange language objects for the BMXNOR0200H module.

System Words

The following table describes the system word (%MW, READ) language objects:

Object	Description
%MWr.m.0.0	exchange status (EXCH_STS): <ul style="list-style-type: none"> bit 0 = 1: reading of status words of the channel in progress (STS_IN_PROGR) bit 1 = 1: command write in progress (CMD_IN_PROGR)
%MWr.m.0.1	exchange report (EXCH_RPT): <ul style="list-style-type: none"> bit 0 = 1: the channel status cannot be read (STS_ERR) bit 1 = 1: a command cannot be written to the channel (CMD_ERR) <p>Note: Always 0 for the BMX P34 20*0</p>

Status Words

The following table describes the status word (%MW or %MD, READ) language objects:

Object	Description
%MWr.m.0.2	CH_FLT bits: <ul style="list-style-type: none"> bit 4 (%MWr.m.0.2.4) = 1: internal error detected or self-test cannot complete (INTERNAL_FLT) bit 7 (%MWr.m.0.2.7) = 1: application cannot be run (APPLI_FLT)
%MWr.m.0.3	Ethernet Port Global status (ETH_PORT_STATUS)
%MDr.m.0.4	IP address (IP_ADDR)
%MWr.m.0.6	number of denied Port 502 connections (P502_NB_CONN_DENIED)
%MWr.m.0.7	number of received messages on the Ethernet port per second (BW_NB_MSG_IN)
%MWr.m.0.8	number of useless messages filtered by the Ethernet port per second (BW_NB_MSG_FILTER)
%MWr.m.0.9	number of messages dropped by the Ethernet port per second (BW_NB_MSG_DROP)
%MWr.m.0.10	maximum number of received messages on the Ethernet port per second (BW_MAX_MSG_IN)
%MWr.m.0.11	maximum number of useless messages filtered by the Ethernet port per second (BW_MAX_MSG_FILTER)
%MWr.m.0.12	maximum number of messages dropped by the Ethernet port per second (BW_MAX_MSG_DROP)

Object	Description
%MWr.m.0.13	maximum number of Multicast messages received per second (BW_MAX_MSG_MC)
%MWr.m.0.14	maximum number of broadcast messages received per second (BW_MAX_MSG_BC)
%MWr.m.0.15	reserved for future use

Command Words

The following table describes the command word (%MW, WRITE) language objects:

Object	Description
%MWr.m.0.16	Ethernet command word (ETH_CMD): <ul style="list-style-type: none"> ● bit 0 = 1 for Ethernet Component Reset (ETH_RESET) ● bit 1 = 1 for Max Message Counters reset (BW_CNT_RESET) ● bit 2 = 1 for Messaging counters reset (P502_CNT_RESET)
%MWr.m.0.17	reserved for modulo 4 address alignment



!

10/100 Base-T

An adaptation of the IEEE 802.3 (Ethernet) standard, the 10/100 Base-T standard uses twisted-pair wiring with a maximum segment length of 100 m (328 ft) and terminates with an RJ-45 connector. A 10/100Base-T network is capable of transmitting data on normal Ethernet (10 Mbit/s) and Fast Ethernet (100 Mbits/s) networks.

B

BOOTP

bootstrap protocol. A UDP/IP protocol that allows an Internet node to obtain its IP parameters based on its MAC address.

bridge

A bridge device connects two or more physical networks that use the same protocol. Bridges read frames and decide whether to transmit or block them based on their destination address.

broadcast

Broadcast communications send packets from a one station to every network destination. Broadcast messages pertain to every network device or only one device for which the address is not known. (See *multicast* and *unicast*).

C

ConneXview

ConneXview is a set of configuration files to be used with HiVision 6.x network management software from Hirschmann Electronics GmbH & Co. KG. ConneXview makes it possible to manage Schneider Electric Transparent Factory devices using HiVision 6.0 or newer. ConneXview is built on the widely used simple network management protocol (SNMP).

D

DHCP

dynamic host configuration protocol. DHCP is a TCP/IP protocol that allows network devices (DHCP clients) to obtain their IP addresses from a DHCP server through a request to the server.

E

Ethernet

A LAN cabling and signaling specification used to connect devices within a defined area, e.g., a building. Ethernet uses a bus or a star topology to connect different nodes on a network.

G

gateway

A device that connects networks with dissimilar network architectures and which operates at the Application Layer of the OSI model. This term may refer to a router.

H

HTTP server

The installed HTTP server transmits Web pages between a server and a browser, providing Ethernet communications modules with easy access to devices anywhere in the world from standard browsers such as Internet Explorer or Netscape Navigator.

I

IODDT

input/output derived data type. IODDT is a structured data type representing a module or a channel of a PLC module. Each application expert module possesses its own IODDTs.

IP

Internet protocol. That part of the TCP/IP protocol family that tracks the Internet addresses of nodes, routes outgoing messages, and recognizes incoming messages.

IP address

Internet protocol address. This 32-bit address is assigned to hosts that use TCP/IP.

L

LAN

local area network. A short-distance data communications network.

M

MAC address

media access control address. A 48-bit number, unique on a network, that is programmed into each network card or device when it is manufactured.

P

PLC

programmable logic controller. The PLC is the brain of an industrial manufacturing process. It automates a process as opposed to relay control systems. PLCs are computers suited to survive the harsh conditions of the industrial environment.

port 502

TCP/IP reserves specific server ports for specific applications through IANA (Internet Assigned Numbers Authority). Modbus requests are sent to registered software port 502.

R

router

A router device connects two or more sections of a network and allows information to flow between them. A router examines every packet it receives and decides whether to block the packet from the rest of the network or transmit it. The router attempts to send the packet through the network on an efficient path.

RTU

Remote Terminal Unit.

S

SNMP

simple network management protocol. The UDP/IP standard protocol used to monitor and manage devices on an IP network.

SNMP agent

The SNMP application that runs on a network device.

subnet mask

The subnet mask is a bit mask that identifies or determines which bits in an IP address correspond to the network address and which correspond to the subnet portions of the address. The subnet mask comprises the network address plus the bits reserved for identifying the subnetwork.

switch

A network switch connects two or more separate network segments and allows traffic to be passed between them. A switch determines whether a frame should be blocked or transmitted based on its destination address.

T

TCP/IP

Transmission Control Protocol/Internet Protocol. TCP/IP is the communication protocol of the Internet.

TFE

transparent factory Ethernet. Schneider Electric's open automation framework based on TCP/IP.

Transparent Ready

Schneider Electric's Transparent Ready products (based on universal Ethernet TCP/IP and Web technologies) can be integrated into real-time, data sharing systems, with no need for interfaces.

U

UDP

user datagram protocol. UDP is an Internet communications protocol defined by IETF RFC 768. This protocol facilitates the direct transmission of datagrams on IP networks. UDP/IP messages do not expect a response, and are therefore ideal for applications in which dropped packets do not require retransmission (such as streaming video and networks that demand real-time performance).



B

BMXNOR0200H
description, *26*
BMXRWS128MWF, *44*

C

certifications, *37*
clock synchronization, *96*

D

Datalogging
configuration, *131*
properties, *129*
datalogging service, *128*
recommendation, *136*
debugging communication, *182*
diagnostic message
without memory card, *45*
DNP3 Data Object Mapping, *292, 308*
DNP3 Event Queue Setting, *313*

E

email service
configuration, *138*
Ethernet modules
communication requirements, *23*
device name, *54*
hardware, *54*
hardware requirements, *23*
language objects, *395*
Ethernet Port, *31*

F

frame size
Ethernet, *58*

G

grounding, *42*

I

IEC Data Object Mapping, *251, 262*
IEC Event Queue Setting, *264*
Interoperability, *331*

M

memory card
features, *44*
MIB, *62*
Modbus TCP messaging, *50*
Modbus TCP/IP
messaging, *57*

N

Network Management Protocol, *50*
Network Time Protocol, *51*
NMT, *50*
NTP, *51*

P

P/N, *267*
parameter settings, *396*

S

SD memory cards, *44*
Serial Link, *34*

services

 BootP, *51*

 DHCP, *51*

 FDR, *51*

 FTP, *51*

 Modbus TCP messaging, *50*

 Modbus TCP/IP messaging, *57*

 NMT, *50*

 NTP, *51*

 SMTP, *51*

 SNMP, *51, 61*

 SOAP, *51*

SMTP, *51*

SNMP, *51, 61*

SOAP, *51*

SOAP Web Services, *66*

standards, *37*

T

T_COM_ETH_BMX, *401*

time stamp, *101*

time synchronization, *96*